



**TWO-STAGE, VARIABLE SPEED  
ECM GAS FURNACE**  
**80% AFUE**  
*HEATING INPUT: 60,000–100,000 BTU/H*

### ■ Contents

Nomenclature.....	2
Product Specifications.....	3
Dimensions .....	5
Airflow Data .....	7
Wiring Diagram .....	14
Accessories .....	15

### ■ Standard Features

- Compatible with Daikin *One+* smart thermostat and other Daikin communicating equipment
- Heavy-duty stainless-steel dual-diameter, tubular heat exchanger
- Two-stage gas valve provides quiet, economical heating
- Durable Silicon Nitride igniter
- Quiet two-speed draft inducer
- Self-diagnostic control board with constant memory fault code history output to a dual 7-segment display
- Color-coded low-voltage terminals with provisions for electronic air cleaner and humidifier
- Efficient and quiet variable-speed airflow system gently ramps up or down according to heating or cooling demand
- Multiple continuous fan speed options offer quiet air circulation
- Auto-Comfort and enhanced dehumidification modes available
- California Low NO<sub>x</sub> emissions-compliant models available
- Can no longer be installed in California's South Coast Air Quality Management District (SCAQMD) on or after October 1, 2019
- AHRI Certified; ETL Listed

### ■ Cabinet Features

- Multi-position installation:  
DM80VC: Upflow, horizontal left or right.  
DC80VC: Downflow, horizontal left or right.  
Convenient left or right connection for gas and electrical service
- Cabinet air leakage ( $Q_{Leak} \leq 2\%$ )
- Heavy-gauge steel cabinet with durable baked-enamel finish
- Fully insulated heat exchanger and blower section



\* Complete warranty details available from your local dealer or at [www.daikincomfort.com](http://www.daikincomfort.com). To receive the Lifetime Heat Exchanger Limited Warranty (good for as long as you own your home), the 12-Year Unit Replacement Limited Warranty and the 12-Year Parts Limited Warranty, online registration must be completed within 60 days of installation. Additional requirements for annual maintenance are required for the Unit Replacement Limited Warranty. Online registration and some of the additional requirements are not required in California or Quebec.

	D	M	80	V	C	060	3	B	X	*	*	
	1	2	3,4	5	6	7,8,9	10	11	12	13	14	
<b>Brand</b>											<b>Minor Revision</b>	
D - Daikin Brand											A - Initial Release B - 1st Revision	
<b>Configuration</b>											<b>Major Revision</b>	
M - Upflow/Horizontal C - Downflow/Horizontal D - Dedicated Downflow											A - Initial Release B - 1st Revision	
<b>AFUE</b>											<b>NOx</b>	
97 - 97-98% AFUE    92 - 92% AFUE 96 - 96% AFUE    80 - 80% AFUE											N - Natural Gas X - Low NOx	
<b>Gas Valve</b>											<b>Cabinet Width</b>	
M - Modulating            H - Convertible Two-Stage V - Two Stage            S - Single Stage											A - 14"    C - 21" B - 17½"    D - 24½"	
<b>Motor</b>											<b>Maximum CFM</b>	
C - Variable Speed ECM / Communicating E - Multi-Speed ECM            S - Multi-Speed PSC											2 - 800 CFM 3 - 1200 CFM 4 - 1600 CFM 5 - 2000 CFM	
<b>MBTU/h</b>												
040 - 40,000 BTU/h            100 - 100,000 BTU/h 060 - 60,000 BTU/h            120 - 120,000 BTU/h 080 - 80,000 BTU/h            140 - 140,000 BTU/h												

	DM80VC 0603B*A	DM80VC 0604B*A	DM80VC 0803B*A	DM80VC 0804C*A	DM80VC 0805C*A	DM80VC 0805D*A	DM80VC 1005C*A
<b>HEATING CAPACITY</b>							
High Fire Input (BTU/h) <sup>1</sup>	60,000	60,000	80,000	80,000	80,000	80,000	100,000
High Fire Output (BTU/h) <sup>1</sup> (below)							
Natural Gas	48,000	48,000	64,000	64,000	64,000	64,000	80,000
LP Gas	48,000	48,000	64,000	64,000	64,000	64,000	80,000
Low Fire Input (BTU/h) <sup>1</sup>	42,000	42,000	56,000	56,000	56,000	56,000	70,000
Low Fire Output (BTU/h) <sup>1</sup> (below)							
Natural Gas	33,600	33,600	44,800	44,800	44,800	44,800	56,000
LP Gas	33,600	33,600	44,800	44,800	44,800	44,800	56,000
AFUE <sup>2</sup>	80	80	80	80	80	80	80
Available AC @ 0.5" ESP	1.5 - 3.0	1.5 - 4.0	1.5 - 3.0	3.0 - 4.0	2.0 - 5.0	2.5 - 5.0	2.0 - 5.0
Temperature Rise Range (° F)	15-45 / 15-45	20-50 / 20-50	30-60 / 35-65	25-55 / 20-50	20-50 / 20-50	20-50 / 30-60	25-55 / 25-55
<b>CIRCULATOR BLOWER</b>							
Size (D x W)	10" x 8"	10" x 8"	10" x 8"	11" x 10"	10" x 10"	11" x 10"	10" x 10"
Horsepower - RPM	¾	¾	1/2	1/2	¾	3/4	¾
Speed	Variable	Variable	Variable	Variable	Variable	Variable	Variable
Vent Diameter <sup>3</sup>	4"	4"	4"	4"	4"	4"	4"
No. of Burners	3	3	4	4	4	4	4
<b>ELECTRICAL DATA</b>							
Min. Circuit Ampacity <sup>4</sup>	7.75	10.6	7.75	7.75	10.6	10.6	10.6
Max. Overcurrent Device (amps) <sup>5</sup>	15	15	15	15	15	15	15
<b>SHIP WEIGHT (LBS)</b>	105	107	110	118	121	129	124

<sup>1</sup> Natural Gas BTU/h; for altitudes above from 0' to 4,500' above sea level, reduce input rating 4% for each 1,000' above 4,500' altitude. Low-fire rate is 70% of high-fire rate.

<sup>2</sup> DOE AFUE based upon Isolated Combustion System (ICS)

<sup>3</sup> Minimum Circuit Ampacity = (1.25 x Circulator Blower Amps) + ID Blower amps. Wire size should be determined in accordance with National Electrical Codes. Extensive wire runs will require larger wire sizes.

<sup>4</sup> Maximum Overcurrent Protection Device refers to maximum recommended fuse or circuit breaker size. May use fuses or HACR-type circuit breakers of the same size as noted.

**NOTES**

- All furnaces are manufactured for use on 115 VAC, 60 Hz, single-phase electrical supply.
- Gas Service Connection ½" FPT
- Important: Size fuses and wires properly and make electrical connections in accordance with the National Electrical Code and/or all existing local codes.

	DC80VC 0603BXA	DC80VC 0803BXA	DC80VC 0805CXA	DC80VC 1005CXA
<b>HEATING CAPACITY</b>				
High Fire Input (BTU/h) <sup>1</sup>	60,000	80,000	80,000	100,000
High Fire Output (BTU/h) <sup>1</sup> (below)				
Natural Gas	48,000	64,000	64,000	80,000
LP Gas	48,000	64,000	64,000	80,000
Low Fire Input (BTU/h) <sup>1</sup>	42,000	56,000	56,000	70,000
Low Fire Output (BTU/h) <sup>1</sup> (below)				
Natural Gas	33,600	44,800	44,800	56,000
LP Gas	33,600	44,800	44,800	56,000
AFUE <sup>2</sup>	80	80	80	80
Available AC @ 0.5" ESP	1.5 - 3.0	1.5 - 3.0	2.0 - 5.0	2.0 - 5.0
Temperature Rise Range (° F)	25-55 / 40-70	30-60 / 30-60	25-55 / 30-60	20-50 / 25-55
<b>CIRCULATOR BLOWER</b>				
Size (D x W)	10" x 8"	10" x 8"	10" x 10"	10" x 10"
Horsepower - RPM	¾	½	¾	¾
Speed	Variable	Variable	Variable	Variable
Vent Diameter <sup>3</sup>	4"	4"	4"	4"
No. of Burners	3	4	4	5
<b>ELECTRICAL DATA</b>				
Min. Circuit Ampacity <sup>4</sup>	7.75	7.75	10.6	10.6
Max. Overcurrent Device (amps) <sup>5</sup>	15	15	15	15
<b>SHIP WEIGHT (LBS)</b>	105	109	125	129

<sup>1</sup> Natural Gas BTU/h; for altitudes above from 0' to 4,500' above sea level, reduce input rating 4% for each 1,000' above 4,500' altitude. Low-fire rate is 70% of high-fire rate.

<sup>2</sup> DOE AFUE based upon Isolated Combustion System (ICS)

<sup>3</sup> Minimum Circuit Ampacity = (1.25 x Circulator Blower Amps) + ID Blower amps. Wire size should be determined in accordance with National Electrical Codes. Extensive wire runs will require larger wire sizes.

<sup>4</sup> Maximum Overcurrent Protection Device refers to maximum recommended fuse or circuit breaker size. May use fuses or HACR-type circuit breakers of the same size as noted.

**NOTES**

- All furnaces are manufactured for use on 115 VAC, 60 Hz, single-phase electrical supply.
- Gas Service Connection ½" FPT
- Important: Size fuses and wires properly and make electrical connections in accordance with the National Electrical Code and/or all existing local codes.

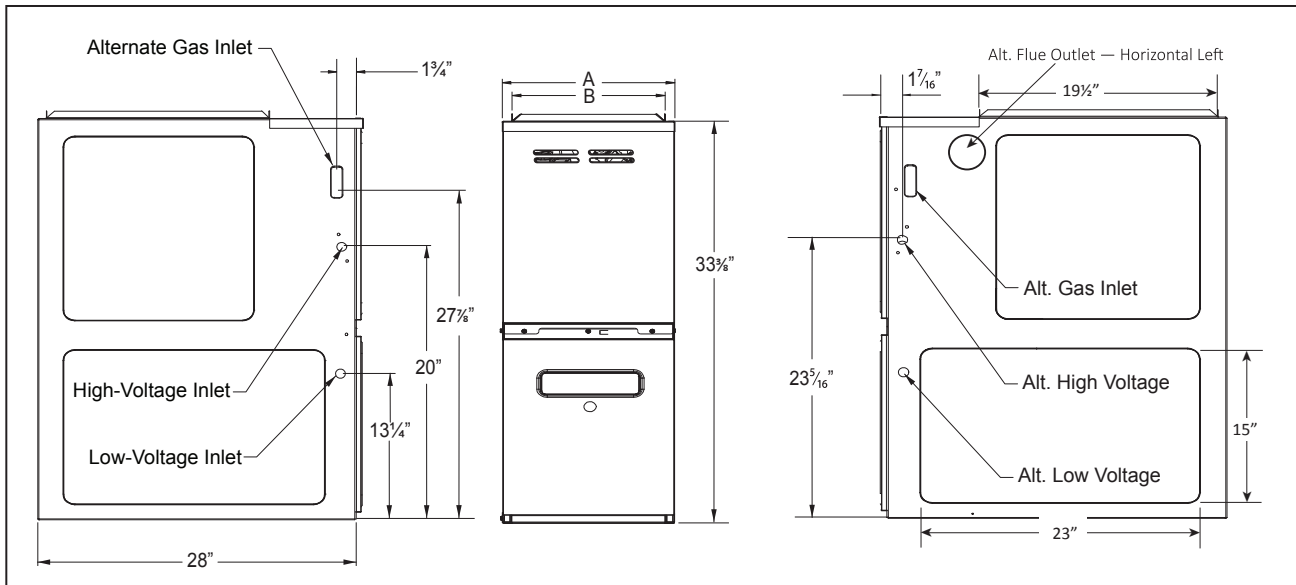

MODEL	DIMENSIONS			WIDTHS	
	W	D	H	A	B
DM80VC0603B*A	17 1/2"	28"	33 7/8"	17 1/2"	16"
DM80VC0604B*A	17 1/2"	28"	33 7/8"	17 1/2"	16"
DM80VC0803B*A	17 1/2"	28"	33 7/8"	17 1/2"	16"
DM80VC0804C*A	21"	28"	33 7/8"	21"	19 1/2"
DM80VC0805C*A	21"	28"	33 7/8"	21"	19 1/2"
DM80VC1005C*A	21"	28"	33 7/8"	21"	19 1/2"
DM80VC1005D*A	24 1/2"	28"	33 7/8"	24 1/2"	23"

**MINIMUM CLEARANCES TO COMBUSTIBLE MATERIALS**

SIDES	REAR	FRONT <sup>1</sup>	VENT <sup>2</sup>		TOP
			SW	B	
1	0	3	6	1	1

Approved for line contact in the horizontal position.

<sup>1</sup> 24" clearance for serviceability recommended.

<sup>2</sup> Single Wall Vent (SW) to be used only as a connector. Refer to the venting tables outlined in the Installation Manual for additional venting requirements.

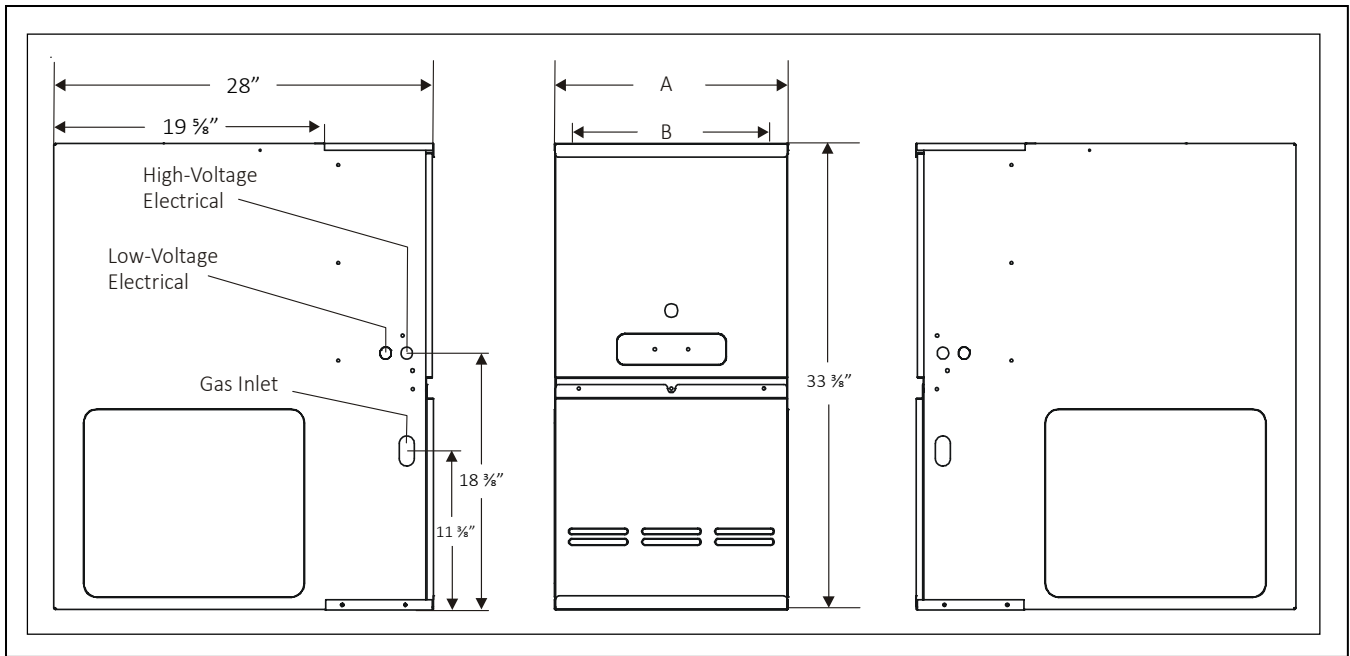

MODEL	DIMENSIONS		
	W	D	H
DC80VC0603BXA	17½"	28"	33¾"
DC80VC0803BXA	17½"	28"	33¾"
DC80VC0805CXA	21"	28"	33¾"
DC80VC1005CXA	21"	28"	33¾"

WIDTHS	
A	B
17½"	16"
17½"	16"
21"	19½"
21"	19½"

**MINIMUM CLEARANCES TO COMBUSTIBLE MATERIALS**

SIDES	REAR	FRONT	BOTTOM	VENT		TOP
				SW	B	
1	0	3	C	6	1	1

C = If placed on combustible floor, the floor MUST be wood ONLY.

**Notes:**

- For servicing or cleaning, a 24" front clearance is recommended.
- Unit connections (electrical, flue, and drain) may necessitate greater clearances than the minimum clearances listed above.
- In all cases, accessibility clearance must take precedence over clearances from the enclosure where accessibility clearances are greater.
- Refer to the appropriate USA and Canadian codes:  
 In the USA: the National Fuel Gas Code NFPA 54 / ANSI Z223.1  
 In Canada: the Canada National Standard of Canada, CAN/CSA B149.1 and CAN/CSA B142.2

**DM80VC0603B\*A\***  
Cooling Speeds  
(@ .1" - .8" w.c. ESP)

TAP	ADJUST	HIGH-STAGE CFM	LOW-STAGE CFM
A	Minus 10%	628	421
	Minus 5%	663	445
	Normal	698	468
	Plus 5%	732	491
	Plus 10%	768	515
B	Minus 10%	762	525
	Minus 5%	804	555
	Normal	847	584
	Plus 5%	889	613
	Plus 10%	932	642
C	Minus 10%	930	664
	Minus 5%	982	701
	Normal	1,034	738
	Plus 5%	1,086	775
	Plus 10%	1,137	812
D	Minus 10%	1,128	785
	Minus 5%	1,190	828
	Normal	1,253	872
	Plus 5%	1,316	915
	Plus 10%	1,378	959

**DM80VC0603B\*A\***  
Heating Speeds  
(@ .1" - .5" w.c. ESP; Rise Range: 15° - 45°F)

TAP	ADJUST	HIGH-STAGE CFM	LOW-STAGE CFM	RISE (°F)
A	Minus 10%	911	662	NA
	Minus 5%	961	698	NA
	Normal	1,012	735	44
	Plus 5%	1,063	772	42
	Plus 10%	1,113	809	40
B	Minus 10%	988	724	45
	Minus 5%	1,043	764	43
	Normal	1,098	804	40
	Plus 5%	1,153	844	39
	Plus 10%	1,208	884	37
C	Minus 10%	1,081	787	41
	Minus 5%	1,141	830	39
	Normal	1,201	874	37
	Plus 5%	1,261	918	35
	Plus 10%	1,321	961	34
D	Minus 10%	1,179	841	38
	Minus 5%	1,245	887	36
	Normal	1,310	934	34
	Plus 5%	1,376	981	32
	Plus 10%	1,441	1,027	31

**DM80VC0604B\*A\***  
Cooling Speeds  
(@ .1" - .8" w.c. ESP)

TAP	ADJUST	HIGH-STAGE CFM	LOW-STAGE CFM
A	Minus 10%	540	351
	Minus 5%	570	371
	Normal	600	390
	Plus 5%	630	410
	Plus 10%	660	429
B	Minus 10%	720	468
	Minus 5%	760	494
	Normal	800	520
	Plus 5%	840	546
	Plus 10%	880	572
C	Minus 10%	990	644
	Minus 5%	1,045	679
	Normal	1,100	715
	Plus 5%	1,155	751
	Plus 10%	1,210	787
D	Minus 10%	1,260	819
	Minus 5%	1,330	865
	Normal	1,400	910
	Plus 5%	1,470	956
	Plus 10%	1,540	1,001

**DM80VC0604B\*A\***  
Heating Speeds  
(@ .1" - .5" w.c. ESP; Rise Range: 20° - 50°F)

TAP	ADJUST	HIGH-STAGE CFM	LOW-STAGE CFM	RISE (°F)
A	Minus 10%	1,125	788	40
	Minus 5%	1,188	831	37
	Normal	1,250	875	36
	Plus 5%	1,313	919	34
	Plus 10%	1,375	963	32
B	Minus 10%	1,215	851	37
	Minus 5%	1,283	898	35
	Normal	1,350	945	33
	Plus 5%	1,418	992	31
	Plus 10%	1,485	1,040	30
C	Minus 10%	1,305	914	34
	Minus 5%	1,378	964	32
	Normal	1,450	1,015	31
	Plus 5%	1,523	1,066	29
	Plus 10%	1,595	1,117	28
D	Minus 10%	1,395	977	32
	Minus 5%	1,473	1,031	30
	Normal	1,550	1,085	29
	Plus 5%	1,628	1,139	27
	Plus 10%	1,705	1,194	26

See Notes on page 10.

DM80VC AIRFLOW DATA (CONT.)

**DM80VC0803B\*A\***  
**COOLING SPEEDS**  
 (@ .1" - .8" w.c. ESP)

TAP	ADJUST	HIGH-STAGE CFM	LOW-STAGE CFM
A	Minus 10%	657	419
	Minus 5%	694	442
	Normal	730	465
	Plus 5%	767	488
	Plus 10%	803	512
B	Minus 10%	790	526
	Minus 5%	834	555
	Normal	878	584
	Plus 5%	922	613
	Plus 10%	966	642
C	Minus 10%	950	702
	Minus 5%	1,003	741
	Normal	1,056	780
	Plus 5%	1,109	819
	Plus 10%	1,162	858
D	Minus 10%	1,102	832
	Minus 5%	1,163	878
	Normal	1,224	924
	Plus 5%	1,285	970
	Plus 10%	1,346	1,016

**DM80VC0803B\*A\***  
**HEATING SPEEDS**  
 (@ .1" - .5" w.c. ESP; RISE RANGE 30°F - 60°F)

TAP	ADJUST	HIGH-STAGE CFM	LOW-STAGE CFM	RISE (°F)
A	Minus 10%	911	662	NA
	Minus 5%	961	698	NA
	Normal	1,012	735	59
	Plus 5%	1,063	772	56
	Plus 10%	1,113	809	53
B	Minus 10%	988	724	60
	Minus 5%	1,043	764	57
	Normal	1,098	804	54
	Plus 5%	1,153	844	51
	Plus 10%	1,208	884	49
C	Minus 10%	1,081	787	55
	Minus 5%	1,141	830	52
	Normal	1,201	874	49
	Plus 5%	1,261	918	47
	Plus 10%	1,321	961	45
D	Minus 10%	1,179	841	50
	Minus 5%	1,245	887	48
	Normal	1,310	934	45
	Plus 5%	1,376	981	43
	Plus 10%	1,441	1,027	41

**DM80VC0804C\*A\***  
**COOLING SPEEDS**  
 (@ .1" - .8" w.c. ESP)

TAP	ADJUST	HIGH-STAGE CFM	LOW-STAGE CFM
A	Minus 10%	771	529
	Minus 5%	814	559
	Normal	857	588
	Plus 5%	900	617
	Plus 10%	943	647
B	Minus 10%	946	668
	Minus 5%	998	705
	Normal	1,051	742
	Plus 5%	1,104	779
	Plus 10%	1,156	816
C	Minus 10%	1,156	790
	Minus 5%	1,220	834
	Normal	1,284	878
	Plus 5%	1,348	922
	Plus 10%	1,412	966
D	Minus 10%	1,454	944
	Minus 5%	1,535	997
	Normal	1,616	1,049
	Plus 5%	1,697	1,101
	Plus 10%	1,778	1,154

**DM80VC0804C\*A\***  
**HEATING SPEEDS**  
 (@ .1" - .5" w.c. ESP; RISE RANGE: 25°F - 55°F)

TAP	ADJUST	HIGH-STAGE CFM	LOW-STAGE CFM	RISE (°F)
A	Minus 10%	1,111	817	53
	Minus 5%	1,172	863	51
	Normal	1,234	908	48
	Plus 5%	1,296	953	46
	Plus 10%	1,357	999	44
B	Minus 10%	1,229	887	48
	Minus 5%	1,297	937	46
	Normal	1,365	986	43
	Plus 5%	1,433	1,035	41
	Plus 10%	1,502	1,085	39
C	Minus 10%	1,351	955	44
	Minus 5%	1,426	1,008	42
	Normal	1,501	1,061	39
	Plus 5%	1,576	1,114	38
	Plus 10%	1,651	1,167	36
D	Minus 10%	1,456	1,028	41
	Minus 5%	1,537	1,085	39
	Normal	1,618	1,142	37
	Plus 5%	1,699	1,199	35
	Plus 10%	1,780	1,256	33

See Notes on page 10.



**DM80VC0805C\*A\***  
Cooling Speeds  
(@ .1" - .8" w.c. ESP)

TAP	ADJUST	HIGH-STAGE CFM	LOW-STAGE CFM
A	Minus 10%	720	468
	Minus 5%	760	494
	Normal	800	520
	Plus 5%	840	546
	Plus 10%	880	572
B	Minus 10%	990	644
	Minus 5%	1,045	679
	Normal	1,100	715
	Plus 5%	1,155	751
	Plus 10%	1,210	787
C	Minus 10%	1,260	819
	Minus 5%	1,330	865
	Normal	1,400	910
	Plus 5%	1,470	956
	Plus 10%	1,540	1,001
D	Minus 10%	1,620	1,053
	Minus 5%	1,710	1,112
	Normal	1,800	1,170
	Plus 5%	1,890	1,229
	Plus 10%	1,980	1,287

**DM80VC0805C\*A\***  
Heating Speeds  
(@ .1" - .5" w.c. ESP; Rise Range: 20° - 50°F)

TAP	ADJUST	HIGH-STAGE CFM	LOW-STAGE CFM	RISE (°F)
A	Minus 10%	1,350	945	44
	Minus 5%	1,425	998	42
	Normal	1,500	1,050	40
	Plus 5%	1,575	1,103	38
	Plus 10%	1,650	1,155	36
B	Minus 10%	1,440	1,008	41
	Minus 5%	1,520	1,064	40
	Normal	1,600	1,120	37
	Plus 5%	1,680	1,176	35
	Plus 10%	1,760	1,232	34
C	Minus 10%	1,530	1,071	39
	Minus 5%	1,615	1,131	37
	Normal	1,700	1,190	35
	Plus 5%	1,785	1,250	33
	Plus 10%	1,870	1,309	32
D	Minus 10%	1,620	1,134	37
	Minus 5%	1,710	1,197	35
	Normal	1,800	1,260	33
	Plus 5%	1,890	1,323	31
	Plus 10%	1,980	1,386	30

**DM80VC0805D\*A\***  
Cooling Speeds  
(@ .1" - .8" w.c. ESP)

TAP	ADJUST	HIGH-STAGE CFM	LOW-STAGE CFM
A	Minus 10%	747	524
	Minus 5%	789	553
	Normal	830	582
	Plus 5%	872	611
	Plus 10%	913	640
B	Minus 10%	1,025	707
	Minus 5%	1,082	747
	Normal	1,139	786
	Plus 5%	1,196	825
	Plus 10%	1,253	865
C	Minus 10%	1,405	942
	Minus 5%	1,483	995
	Normal	1,561	1,047
	Plus 5%	1,639	1,099
	Plus 10%	1,717	1,152
D	Minus 10%	1,769	1,193
	Minus 5%	1,868	1,260
	Normal	1,966	1,326
	Plus 5%	2,064	1,392
	Plus 10%	2,163	1,459

**DM80VC0805D\*A\***  
Heating Speeds  
(@ .1" - .5" w.c. ESP; Rise Range: 20° - 50°F)

TAP	ADJUST	HIGH-STAGE CFM	LOW-STAGE CFM	RISE (°F)
A	Minus 10%	1,798	1,247	33
	Minus 5%	1,898	1,317	31
	Normal	1,998	1,386	30
	Plus 5%	2,098	1,455	28
	Plus 10%	2,198	1,525	27
B	Minus 10%	1,806	1,265	33
	Minus 5%	1,907	1,335	31
	Normal	2,007	1,405	30
	Plus 5%	2,107	1,475	28
	Plus 10%	2,208	1,546	27
C	Minus 10%	1,820	1,274	33
	Minus 5%	1,921	1,344	31
	Normal	2,022	1,415	29
	Plus 5%	2,123	1,486	28
	Plus 10%	2,224	1,557	27
D	Minus 10%	1,842	1,292	32
	Minus 5%	1,945	1,363	30
	Normal	2,047	1,435	29
	Plus 5%	2,149	1,507	28
	Plus 10%	2,252	1,579	26

See Notes on page 10.

**DM80VC1005C\*A**  
**COOLING SPEEDS**  
 (@ .1" - .8" w.c. ESP)

TAP	ADJUST	HIGH-STAGE CFM	LOW-STAGE CFM
A	Minus 10%	720	468
	Minus 5%	760	494
	Normal	800	520
	Plus 5%	840	546
	Plus 10%	880	572
B	Minus 10%	990	644
	Minus 5%	1,045	679
	Normal	1,100	715
	Plus 5%	1,155	751
	Plus 10%	1,210	787
C	Minus 10%	1,260	819
	Minus 5%	1,330	865
	Normal	1,400	910
	Plus 5%	1,470	956
	Plus 10%	1,540	1,001
D	Minus 10%	1,620	1,053
	Minus 5%	1,710	1,112
	Normal	1,800	1,170
	Plus 5%	1,890	1,229
	Plus 10%	1,980	1,287

**DM80VC1005C\*A**  
**HEATING SPEEDS**  
 (@ .1" - .5" w.c. ESP; RISE RANGE: 25° - 55°F)

TAP	ADJUST	HIGH-STAGE CFM	LOW-STAGE CFM	RISE (°F)
A	Minus 10%	1,553	1,089	48
	Minus 5%	1,639	1,150	45
	Normal	1,725	1,210	43
	Plus 5%	1,811	1,271	41
	Plus 10%	1,898	1,331	39
B	Minus 10%	1,575	1,103	47
	Minus 5%	1,663	1,164	45
	Normal	1,750	1,225	42
	Plus 5%	1,838	1,286	40
	Plus 10%	1,925	1,348	38
C	Minus 10%	1,598	1,121	46
	Minus 5%	1,686	1,183	44
	Normal	1,775	1,245	42
	Plus 5%	1,864	1,307	40
	Plus 10%	1,953	1,370	38
D	Minus 10%	1,620	1,134	46
	Minus 5%	1,710	1,197	43
	Normal	1,800	1,260	41
	Plus 5%	1,890	1,323	39
	Plus 10%	1,980	1,386	37

**NOTES**

- These charts are for furnaces installed at 0' - 4,500'. At higher altitudes, a properly de-rated unit will have the same temperature rise at a particular CFM, while the ESP at that CFM will be lower.
- The installation must be adjusted to obtain a temperature rise within the range listed on the furnace nameplate.
- Do not operate above .5" w.c. ESP in heating mode.
- Propane gas installations will have a high-stage rise approximately 4°F lower than shown in the tables.

**MINIMUM FILTER SIZES**

MODEL #	DM80VC0604B*	DM80VC0805C*	DM80VC1005C*
Filter Size (in <sup>2</sup> )	(1) 16 x 25 (Side or Bottom)	(1) 16 x 25 (Side or Bottom) <sup>1</sup>	(2) 16 x 25 (Side) or (1) 20 x 25 (Bottom)

Note: Other size filters of equal or greater surface area may be used; filters may also be centrally located.

<sup>1</sup> Use 2 - 16 X 25 filters on side returns or 20 X 25 filter on bottom return if furnace is connected to a cooling unit over 4 tons nominal capacity.

**DC80VC0603BXA\***  
**COOLING SPEEDS**  
 (@ .1" - .8" w.c. ESP)

TAP	ADJUST	HIGH-STAGE CFM	LOW-STAGE CFM
A	Minus 10%	568	371
	Minus 5%	599	391
	Normal	631	412
	Plus 5%	663	433
	Plus 10%	694	453
B	Minus 10%	755	513
	Minus 5%	797	542
	Normal	839	570
	Plus 5%	881	599
	Plus 10%	923	627
C	Minus 10%	945	646
	Minus 5%	998	682
	Normal	1,050	718
	Plus 5%	1,103	754
	Plus 10%	1,155	790
D	Minus 10%	1,115	758
	Minus 5%	1,177	800
	Normal	1,239	842
	Plus 5%	1,301	884
	Plus 10%	1,363	926

**DC80VC0603BXA\***  
**HEATING SPEEDS**  
 (@ .1" - .5" w.c. ESP; RISE RANGE: 25° - 55°F); NR = NOT RECOMMENDED

TAP	ADJUST	HIGH-STAGE CFM	LOW-STAGE CFM	RISE (°F)
A	Minus 10%	996	706	45
	Minus 5%	1,052	745	42
	Normal	1,107	784	40
	Plus 5%	1,162	823	38
	Plus 10%	1,218	862	36
B	Minus 10%	1,078	766	41
	Minus 5%	1,138	808	39
	Normal	1,198	851	37
	Plus 5%	1,258	894	35
	Plus 10%	1,318	936	34
C	Minus 10%	1,184	830	38
	Minus 5%	1,250	876	36
	Normal	1,316	922	34
	Plus 5%	1,382	968	32
	Plus 10%	1,448	1,014	31
D	Minus 10%	1,266	865	35
	Minus 5%	1,337	913	33
	Normal	1,407	961	32
	Plus 5%	1,477	1,009	30
	Plus 10%	1,548	1,057	29

**DC80VC0803BXA\***  
**COOLING SPEEDS**  
 (@ .1" - .8" w.c. ESP)

TAP	ADJUST	HIGH-STAGE CFM	LOW-STAGE CFM
A	Minus 10%	579	381
	Minus 5%	611	402
	Normal	643	423
	Plus 5%	675	444
	Plus 10%	707	465
B	Minus 10%	704	524
	Minus 5%	743	553
	Normal	782	582
	Plus 5%	821	611
	Plus 10%	860	640
C	Minus 10%	884	621
	Minus 5%	928	656
	Normal	982	690
	Plus 5%	1,031	725
	Plus 10%	1,080	759
D	Minus 10%	1,080	722
	Minus 5%	1,140	762
	Normal	1,200	802
	Plus 5%	1,260	842
	Plus 10%	1,320	882

**DC80VC0803BXA\***  
**HEATING SPEEDS**  
 (@ .1" - .5" w.c. ESP; RISE RANGE: 30° - 60°F); NR = NOT RECOMMENDED

TAP	ADJUST	HIGH-STAGE CFM	LOW-STAGE CFM	RISE (°F)
A	Minus 10%	843	621	NR
	Minus 5%	890	656	NR
	Normal	937	690	NR
	Plus 5%	984	725	60
	Plus 10%	1,031	759	57
B	Minus 10%	940	669	NR
	Minus 5%	993	706	60
	Normal	1,045	743	57
	Plus 5%	1,097	780	54
	Plus 10%	1,149	817	52
C	Minus 10%	1,039	726	57
	Minus 5%	1,097	767	54
	Normal	1,155	807	51
	Plus 5%	1,213	847	49
	Plus 10%	1,270	888	47
D	Minus 10%	1,127	783	53
	Minus 5%	1,191	827	50
	Normal	1,254	870	47
	Plus 5%	1,317	914	45
	Plus 10%	1,379	957	43

See Notes on page 12.

DC80VC AIRFLOW DATA (CONT.)

**DC80VC0805CXA\***  
**COOLING SPEEDS**  
 (@ .1" - .8" w.c. ESP)

TAP	ADJUST	HIGH-STAGE CFM	LOW-STAGE CFM
A	Minus 10%	735	479
	Minus 5%	776	505
	Normal	817	532
	Plus 5%	858	559
	Plus 10%	899	585
B	Minus 10%	1,011	659
	Minus 5%	1,067	695
	Normal	1,123	732
	Plus 5%	1,179	769
	Plus 10%	1,235	805
C	Minus 10%	1,301	848
	Minus 5%	1,373	895
	Normal	1,445	942
	Plus 5%	1,517	989
	Plus 10%	1,590	1,036
D	Minus 10%	1,675	1,077
	Minus 5%	1,768	1,137
	Normal	1,861	1,197
	Plus 5%	1,954	1,257
	Plus 10%	2,047	1,317

**DC80VC0805CXA\***  
**HEATING SPEEDS**  
 (@ .1" - .5" w.c. ESP; RISE RANGE: 30° - 60°F; NR = NOT RECOMMENDED)

TAP	ADJUST	HIGH-STAGE CFM	LOW-STAGE CFM	RISE (°F)
A	Minus 10%	1,261	878	47
	Minus 5%	1,331	927	45
	Normal	1,401	976	42
	Plus 5%	1,471	1,025	40
	Plus 10%	1,541	1,074	38
B	Minus 10%	1,346	943	44
	Minus 5%	1,420	996	42
	Normal	1,495	1,048	40
	Plus 5%	1,570	1,100	38
	Plus 10%	1,645	1,153	36
C	Minus 10%	1,421	1,009	42
	Minus 5%	1,500	1,065	40
	Normal	1,579	1,121	38
	Plus 5%	1,658	1,177	36
	Plus 10%	1,737	1,233	34
D	Minus 10%	1,516	1,073	39
	Minus 5%	1,600	1,132	37
	Normal	1,684	1,192	35
	Plus 5%	1,768	1,252	34
	Plus 10%	1,852	1,311	32

**DC80VC1005CXA\***  
**COOLING SPEEDS**  
 (@ .1" - .8" w.c. ESP)

TAP	ADJUST	HIGH-STAGE CFM	LOW-STAGE CFM
A	Minus 10%	763	500
	Minus 5%	806	528
	Normal	848	556
	Plus 5%	890	584
	Plus 10%	933	612
B	Minus 10%	1,059	754
	Minus 5%	1,118	796
	Normal	1,177	838
	Plus 5%	1,236	880
	Plus 10%	1,295	922
C	Minus 10%	1,332	928
	Minus 5%	1,406	979
	Normal	1,480	1,031
	Plus 5%	1,554	1,083
	Plus 10%	1,628	1,134
D	Minus 10%	1,693	1,169
	Minus 5%	1,787	1,234
	Normal	1,881	1,299
	Plus 5%	1,975	1,364
	Plus 10%	2,069	1,429

**DC80VC1005CXA\***  
**HEATING SPEEDS**  
 (@ .1" - .5" w.c. ESP; (RISE RANGE: 20° - 50°F))

TAP	ADJUST	HIGH-STAGE CFM	LOW-STAGE CFM	RISE (°F)
A	Minus 10%	1,432	1,035	NR
	Minus 5%	1,511	1,093	49
	Normal	1,591	1,150	47
	Plus 5%	1,671	1,208	44
	Plus 10%	1,750	1,265	42
B	Minus 10%	1,481	1,069	50
	Minus 5%	1,564	1,129	47
	Normal	1,646	1,188	45
	Plus 5%	1,728	1,247	43
	Plus 10%	1,811	1,307	41
C	Minus 10%	1,532	1,090	48
	Minus 5%	1,617	1,150	46
	Normal	1,702	1,211	44
	Plus 5%	1,787	1,272	41
	Plus 10%	1,872	1,332	40
D	Minus 10%	1,611	1,156	46
	Minus 5%	1,701	1,220	44
	Normal	1,790	1,284	41
	Plus 5%	1,880	1,348	39
	Plus 10%	1,969	1,412	38

**Notes:**

- These charts are for furnaces installed at 0' - 4,500'. At higher altitudes, a properly de-rated unit will have the same temperature rise at a particular CFM, while the ESP at that CFM will be lower.
- The installation must be adjusted to obtain a temperature rise within the range listed on the furnace nameplate.
- In all cases, accessibility clearance must take precedence over clearances from the enclosure where accessibility clearances are greater.
- Do not operate above .5" w.c. ESP in heating mode.
- Propane gas installations will have a high-stage rise approximately 4° lower than shown in the tables.

**CONTINUOUS FAN SPEEDS**

MODEL	FURNACE MAXIMUM CFM	CONTINUOUS FAN SPEED <sup>1,2</sup>
DC80VC0603BXA*	1,760	530
DC80VC0803BXA*	1,760	530
DC80VC0805CXA*	2,000	600
DC80VC1005CXA*	2,000	600

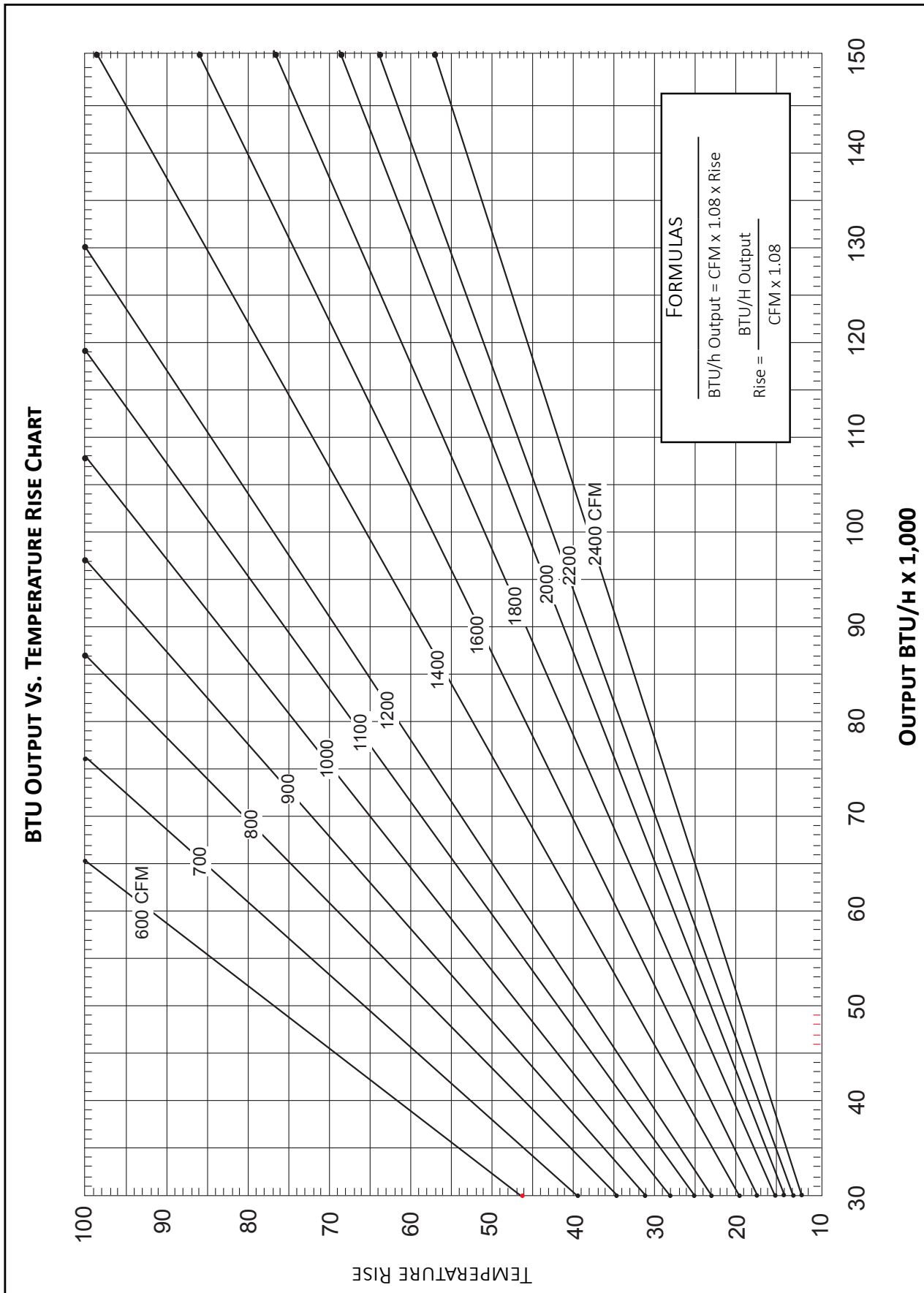

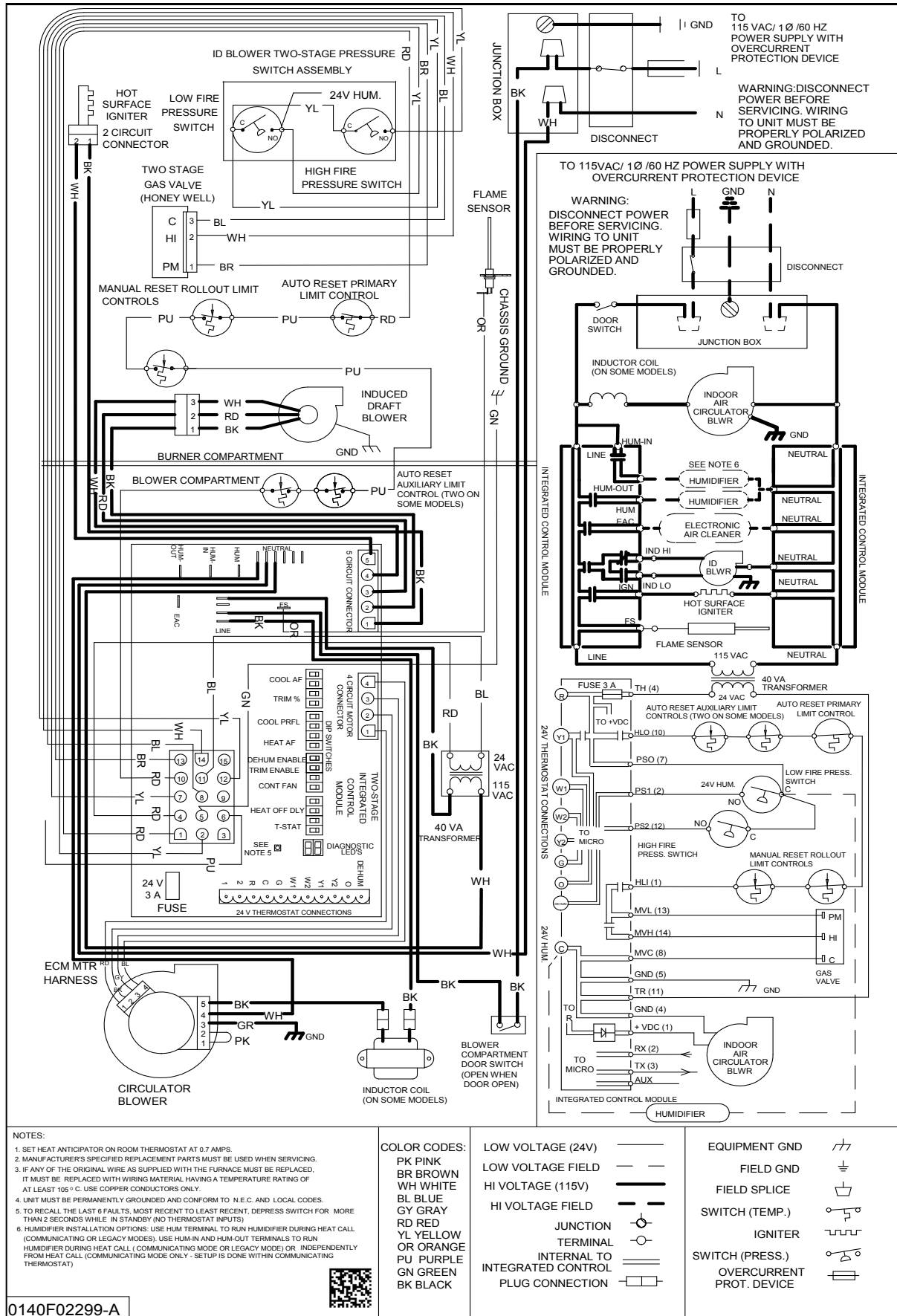

**WARNING**

High Voltage: Disconnect all power before servicing or installing this unit. Multiple power sources may be present. Failure to do so may cause property damage, personal injury, or death.

Wiring is subject to change. Always refer to the wiring diagram on the unit for the most up-to-date wiring.

MODEL	DESCRIPTION
AM11-1425-FA AM11-1625-FB AM11-2025-FC AM11-2525-FD	Deep Pleated Media Air Cleaner
ASAS	Electronic Air Cleaners (sizes =-10,-11,-12 or-18)
AFE18-60A	Fossil Fuel Kit (must be used in a dual-fuel application with a compatible thermostat)
HA-02	High Altitude Kit
LPM-06	LP Conversion Kit (Springs & Orifice) <sup>1</sup>

<sup>1</sup> White-Rodgers and Honeywell valves

