

ML296UHV(X) SERIES UNITS

ML296UHV(X) series units are 90% efficiency gas furnaces used for upflow or horizontal applications only, manufactured with Lennox Duralok™ heat exchangers formed of aluminized steel. ML296UHV(X) units are available in heating capacities of 44,000 to 110,000 Btuh and cooling applications up to 5 tons. Refer to Engineering Handbook for proper sizing.

Units are factory equipped for use with natural gas. Kits are available for conversion to LPG operation. ML296UHV(X) unit meets the California Nitrogen Oxides (NO_x) Standards and California Seasonal Efficiency requirements. All units use a redundant gas valve to assure safety shut-off as required by C.S.A.

All specifications in this manual are subject to change. Procedures outlined in this manual are presented as a recommendation only and do not supersede or replace local or state codes. In the absence of local or state codes, the guidelines and procedures outlined in this manual (except where noted) are recommendations only and do not constitute code.

TABLE OF CONTENTS

Specifications	Page 2
Blower Data	Page 3
I Unit Components	Page 8
II Installation	Page 20
III Start Up	Page 42
IV Heating System Service Checks	Page 43
V Typical Operating Characteristics	Page 46
VI Maintenance	Page 46
VII Wiring and Sequence of Operation	Page 49



⚠ WARNING

Improper installation, adjustment, alteration, service or maintenance can cause property damage, personal injury or loss of life. Installation and service must be performed by a licensed professional HVAC installer (or equivalent), service agency or the gas supplier.

⚠ CAUTION

As with any mechanical equipment, contact with sharp sheet metal edges can result in personal injury. Take care while handling this equipment and wear gloves and protective clothing.

SPECIFICATIONS

Gas	Model No.	ML296UH045XV36B	ML296UH070XV36B
Heating Performance	¹ AFUE	96%	96%
High Fire	Input - Btuh	44,000	66,000
	Output - Btuh	42,000	62,000
	Temperature rise range - °F	35 - 65	50 - 80
	Gas Manifold Pressure (in. w.g.) Nat. Gas / LPG/Propane	3.5 / 10.0	3.5 / 10.0
Low Fire	Input - Btuh	29,000	43,000
	Output - Btuh	28,000	41,000
	Temperature rise range - °F	20 - 50	25 - 55
	Gas Manifold Pressure (in. w.g.) Nat. Gas / LPG/Propane	1.7 / 4.9	1.7 / 4.9
High static - in. w.g.	Heating	0.8	0.8
	Cooling	1.0	1.0
Connections in.	Intake / Exhaust Pipe (PVC)	2 / 2	2 / 2
	Gas pipe size IPS	1/2	1/2
	Condensate Drain Trap (PVC pipe) - i.d. with furnished 90° street elbow	3/4	3/4
	with field supplied (PVC coupling) - o.d.	3/4 slip x 3/4 Mipt 3/4 slip x 3/4 MPT	3/4 slip x 3/4 Mipt 3/4 slip x 3/4 MPT
Indoor Blower	Wheel nominal diameter x width - in.	10 x 9	10 x 9
	Motor output - hp	1/2	1/2
	Tons of add-on cooling	2 - 3	2 - 3
	Air Volume Range - cfm	485 - 1370	500 - 1365
Electrical Data	Voltage	120 volts - 60 hertz - 1 phase	
	Blower motor full load amps	7.7	7.7
	Maximum overcurrent protection	15	15
Shipping Data	lbs. - 1 package	130	138

NOTE - Filters and provisions for mounting are not furnished and must be field provided.

¹ Annual Fuel Utilization Efficiency based on DOE test procedures and according to FTC labeling regulations. Isolated combustion system rating for non-weatherized furnaces.

SPECIFICATIONS

Gas	Model No.	ML296UH090XV48C	ML296UH110XV60C
Heating Performance	¹ AFUE	96%	96%
High Fire	Input - Btuh	88,000	110,000
	Output - Btuh	84,000	106,000
	Temperature rise range - °F	45 - 75	45 - 75
	Gas Manifold Pressure (in. w.g.) Nat. Gas / LPG/Propane	3.5 / 10.0	3.5 / 10.0
Low Fire	Input - Btuh	57,000	72,000
	Output - Btuh	55,000	70,000
	Temperature rise range - °F	30 - 60	35 - 65
	Gas Manifold Pressure (in. w.g.) Nat. Gas / LPG/Propane	1.7 / 4.9	1.7 / 4.9
High static - in. w.g.	Heating	0.8	0.8
	Cooling	1.0	1.0
Connections in.	Intake / Exhaust Pipe (PVC)	2 / 2	2 / 2
	Gas pipe size IPS	1/2	1/2
	Condensate Drain Trap (PVC pipe) - i.d. with furnished 90° street elbow	3/4	3/4
	with field supplied (PVC coupling) - o.d.	3/4 slip x 3/4 Mipt 3/4 slip x 3/4 MPT	3/4 slip x 3/4 Mipt 3/4 slip x 3/4 MPT
Indoor Blower	Wheel nominal diameter x width - in.	11 x 11	11 x 11
	Motor output - hp	3/4	1
	Tons of add-on cooling	2.5 - 4	3 - 5
	Air Volume Range - cfm	680 - 1770	790 - 1955
Electrical Data	Voltage	120 volts - 60 hertz - 1 phase	
	Blower motor full load amps	10.1	12.8
	Maximum overcurrent protection	15	20
Shipping Data	lbs. - 1 package	163	174

NOTE - Filters and provisions for mounting are not furnished and must be field provided.

¹ Annual Fuel Utilization Efficiency based on DOE test procedures and according to FTC labeling regulations. Isolated combustion system rating for non-weatherized furnaces.

BLOWER DATA

ML296UH045XV36B BLOWER PERFORMANCE (less filter)

BOTTOM RETURN AIR, SINGLE SIDE RETURN AIR OR SIDE RETURN AIR WITH OPTIONAL RETURN AIR BASE

0 through 0.8 in. w.g. (Heating) and 0 through 1.0 in. w.g. (Cooling) External Static Pressure Range

"ADJUST" Switch Positions	Speed Switch Positions							
	Second Stage "HEAT" Speed - cfm				Second Stage "COOL" Speed - cfm			
	D	C	¹ B	A	D	C	B	¹ A
+	765	860	960	1050	885	1095	1210	1370
¹ NORM	690	775	855	950	800	990	1115	1255
—	610	710	770	845	710	880	995	1115
"ADJUST" Switch Positions	First Stage "HEAT" Speed - cfm				First Stage "COOL" Speed - cfm			
	D	C	¹ B	A	D	C	B	¹ A
	+	700	790	855	925	615	780	900
¹ NORM	640	705	780	840	565	690	800	895
—	550	645	700	755	500	615	715	790

¹ Factory default jumper setting.

NOTES - The effect of static pressure is included in air volumes shown.

First stage HEAT is approximately **91%** of the same second stage HEAT speed position.

First stage COOL (two-stage air conditioning units only) is approximately **70%** of the same second stage COOL speed position.

Continuous Fan Only speed is approximately **38%** of the same second stage COOL speed position.

ML296UH045XV36B BLOWER MOTOR WATTS (COOLING)

Jumper Speed Positions	Motor Watts @ Various External Static Pressures - in. wg.																			
	First Stage										Second Stage									
	0	0.1	0.2	0.3	0.4	0.5	0.6	0.7	0.8	0	0.1	0.2	0.3	0.4	0.5	0.6	0.7	0.8	0.9	1.0

"+" (Plus) SETTING ("Adjust" Jumper at "+" Setting)

"COOL" Speed	Tap D	20	35	58	79	99	125	148	168	197	63	89	112	140	171	193	222	247	267	295	321
	Tap C	49	73	98	120	141	169	187	212	242	123	147	181	209	243	277	301	333	350	390	409
	Tap B	73	98	123	148	174	196	225	248	274	171	199	237	268	302	341	371	403	431	459	498
	Tap A	93	121	146	182	208	236	261	287	319	250	282	321	360	394	438	474	501	530	529	526

"NORM" (Normal) SETTING ("Adjust" Jumper at "NORM" Setting)

"COOL" Speed	Tap D	16	42	61	77	98	118	140	167	191	38	60	93	116	141	172	196	219	248	271	294
	Tap C	21	42	74	95	126	148	169	194	219	91	116	146	174	211	237	259	291	315	349	369
	Tap B	40	61	94	122	149	175	200	223	249	136	161	195	229	260	289	321	346	375	408	435
	Tap A	71	98	125	150	174	201	223	254	284	194	222	256	292	324	363	399	426	455	483	515

"—" (Minus) SETTING ("Adjust" Jumper at "—" Setting)

"COOL" Speed	Tap D	12	33	47	66	85	104	125	149	167	28	51	77	98	120	143	167	193	214	242	260
	Tap C	18	46	63	80	101	129	152	171	201	65	91	113	144	172	194	219	245	271	299	321
	Tap B	37	59	87	112	133	157	184	205	231	99	126	154	186	209	233	265	293	322	342	377
	Tap A	51	73	99	130	152	176	200	223	249	140	169	201	233	265	284	327	349	386	408	444

BLOWER DATA

ML296UH070XV36B BLOWER PERFORMANCE (less filter)

BOTTOM RETURN AIR, SINGLE SIDE RETURN AIR OR SIDE RETURN AIR WITH OPTIONAL RETURN AIR BASE

0 through 0.8 in. w.g. (Heating) and 0 through 1.0 in. w.g. (Cooling) External Static Pressure Range

"ADJUST" Switch Positions	Speed Switch Positions							
	Second Stage "HEAT" Speed - cfm				Second Stage "COOL" Speed - cfm			
	D	C	¹ B	A	D	C	B	¹ A
+	955	1025	1085	1175	920	1095	1235	1330
¹ NORM	880	935	990	1070	840	990	1120	1200
—	790	840	890	965	750	885	1000	1075
"ADJUST" Switch Positions	First Stage "HEAT" Speed - cfm				First Stage "COOL" Speed - cfm			
	D	C	¹ B	A	D	C	B	¹ A
	+	865	925	980	1055	655	780	850
¹ NORM	795	845	900	975	580	700	765	850
—	715	770	805	865	515	630	690	760

¹ Factory default jumper setting.

NOTES - The effect of static pressure is included in air volumes shown.

First stage HEAT is approximately **90%** of the same second stage HEAT speed position.

First stage COOL (two-stage air conditioning units only) is approximately **70%** of the same second stage COOL speed position.

Continuous Fan Only speed is approximately **38%** of the same second stage COOL speed position.

ML296UH070XV36B BLOWER MOTOR WATTS (COOLING)

Jumper Speed Positions	Motor Watts @ Various External Static Pressures - in. wg.																				
	First Stage										Second Stage										
	0	0.1	0.2	0.3	0.4	0.5	0.6	0.7	0.8	0	0.1	0.2	0.3	0.4	0.5	0.6	0.7	0.8	0.9	1.0	
"+" (Plus) SETTING ("Adjust" Jumper at "+" Setting)																					
"COOL" Speed	Tap D	35	56	79	101	124	146	164	192	214	86	110	139	167	190	223	249	268	297	321	347
	Tap C	50	72	103	126	151	174	199	222	243	134	163	196	230	260	295	318	353	381	414	438
	Tap B	68	94	118	147	170	197	221	246	274	188	220	256	295	328	362	392	433	461	498	520
	Tap A	86	110	146	173	200	224	255	280	306	236	272	311	348	387	418	457	496	529	529	525
"NORM" (Normal) SETTING ("Adjust" Jumper at "NORM" Setting)																					
"COOL" Speed	Tap D	24	45	66	89	109	132	151	174	196	65	88	115	146	170	190	219	243	263	287	312
	Tap C	40	63	87	112	135	158	180	199	226	99	127	158	187	221	250	277	301	329	357	389
	Tap B	58	79	107	130	153	173	198	219	241	147	180	210	245	278	306	340	372	392	421	460
	Tap A	69	93	123	154	176	202	228	252	272	185	217	250	288	320	355	388	415	445	471	498
"—" (Minus) SETTING ("Adjust" Jumper at "—" Setting)																					
"COOL" Speed	Tap D	22	45	61	77	97	117	144	162	190	53	76	99	123	145	170	194	214	236	262	290
	Tap C	27	48	70	96	114	137	157	182	207	74	99	126	157	184	208	234	260	281	312	335
	Tap B	37	61	82	104	129	150	174	196	222	105	133	162	194	224	251	280	305	333	357	386
	Tap A	45	68	98	123	147	173	195	218	241	162	188	211	229	258	277	307	327	354	379	404

BLOWER DATA

ML296UH090XV48C BLOWER PERFORMANCE (less filter)

BOTTOM RETURN AIR, SINGLE SIDE RETURN AIR OR SIDE RETURN AIR WITH OPTIONAL RETURN AIR BASE

0 through 0.8 in. w.g. (Heating) and 0 through 1.0 in. w.g. (Cooling) External Static Pressure Range

"ADJUST" Switch Positions	Speed Switch Positions							
	Second Stage "HEAT" Speed - cfm				Second Stage "COOL" Speed - cfm			
	D	C	¹ B	A	D	C	B	¹ A
+	1205	1290	1330	1555	1135	1355	1525	1765
¹ NORM	1075	1155	1200	1410	1080	1270	1435	1655
—	970	1040	1085	1250	940	1115	1255	1460
"ADJUST" Switch Positions	First Stage "HEAT" Speed - cfm				First Stage "COOL" Speed - cfm			
	D	C	¹ B	A	D	C	B	¹ A
	+	1125	1205	1245	1475	830	985	1095
¹ NORM	1040	1110	1135	1345	765	920	1040	1195
—	935	1000	1030	1210	675	795	900	1040

¹ Factory default jumper setting.

NOTES - The effect of static pressure is included in air volumes shown.

First stage HEAT is approximately **95%** of the same second stage HEAT speed position.

First stage COOL (two-stage air conditioning units only) is approximately **70%** of the same second stage COOL speed position.

Continuous Fan Only speed is approximately **38%** of the same second stage COOL speed position.

ML296UH090XV48C BLOWER MOTOR WATTS (COOLING)

Jumper Speed Positions	Motor Watts @ Various External Static Pressures - in. wg.																				
	First Stage										Second Stage										
	0	0.1	0.2	0.3	0.4	0.5	0.6	0.7	0.8	0	0.1	0.2	0.3	0.4	0.5	0.6	0.7	0.8	0.9	1.0	
"+" (Plus) SETTING ("Adjust" Jumper at "+" Setting)																					
"COOL" Speed	Tap D	48	71	94	117	144	164	186	207	234	110	135	165	194	219	243	274	299	330	351	378
	Tap C	71	94	121	146	169	193	214	245	266	179	208	240	270	302	329	361	392	422	449	481
	Tap B	98	122	154	174	204	228	260	282	305	250	284	314	351	382	412	451	484	517	550	578
	Tap A	146	174	202	229	262	286	315	343	372	405	441	481	514	550	584	623	659	701	735	768
"NORM" (Normal) SETTING ("Adjust" Jumper at "NORM" Setting)																					
"COOL" Speed	Tap D	44	67	86	105	125	145	169	186	211	105	130	154	178	199	225	250	273	297	324	345
	Tap C	65	87	110	131	153	176	197	221	241	158	187	213	242	265	290	314	346	371	404	430
	Tap B	90	114	140	163	182	209	229	257	281	215	248	273	301	330	358	380	412	451	473	507
	Tap A	133	156	183	208	232	254	278	304	332	335	368	397	428	459	491	519	552	582	611	652
"—" (Minus) SETTING ("Adjust" Jumper at "—" Setting)																					
"COOL" Speed	Tap D	23	43	66	88	109	132	152	170	193	67	93	116	139	164	194	218	239	264	286	315
	Tap C	38	59	84	109	133	156	176	199	223	110	134	164	187	215	242	268	295	322	346	366
	Tap B	55	79	102	131	155	177	207	223	252	143	170	196	230	255	284	311	338	369	394	419
	Tap A	85	113	138	162	188	215	242	266	294	220	254	283	315	345	376	416	447	475	510	535

BLOWER DATA

ML296UH110XV60C BLOWER PERFORMANCE (less filter)

BOTTOM RETURN AIR, SINGLE SIDE RETURN AIR OR SIDE RETURN AIR WITH OPTIONAL RETURN AIR BASE

NOTE - Air volumes in **bold** (over 1800 cfm) must have one of the following:

- Single side return air and Optional Return Air Base with transition that must accommodate required 20 x 25 x 1 inch air filter to maintain proper velocity
- Bottom return air
- Return air from both sides
- Bottom and one side return air

0 through 0.8 in. w.g. (Heating) and 0 through 1.0 in. w.g. (Cooling) External Static Pressure Range

“ADJUST” Switch Positions	Speed Switch Positions							
	Second Stage “HEAT” Speed - cfm				Second Stage “COOL” Speed - cfm			
	D	C	¹ B	A	D	C	B	¹ A
+	1680	1805	1950	2105	1405	1620	1820	2055
¹ NORM	1550	1665	1800	1950	1255	1455	1655	1860
—	1400	1505	1625	1750	1145	1335	1515	1700
“ADJUST” Switch Positions	First Stage “HEAT” Speed - cfm				First Stage “COOL” Speed - cfm			
	D	C	¹ B	A	D	C	B	¹ A
	+	1290	1390	1505	1615	1015	1165	1325
¹ NORM	1170	1270	1375	1475	905	1055	1200	1335
—	1070	1160	1250	1345	800	950	1080	1220

¹ Factory default jumper setting.

NOTES - The effect of static pressure is included in air volumes shown.

First stage HEAT is approximately **75%** of the same second stage HEAT speed position.

First stage COOL (two-stage air conditioning units only) is approximately **70%** of the same second stage COOL speed position.

Continuous Fan Only speed is approximately **38%** of the same second stage COOL speed position.

ML296UH110XV60C BLOWER MOTOR WATTS (COOLING)

Jumper Speed Positions	Motor Watts @ Various External Static Pressures - in. wg.																				
	First Stage										Second Stage										
	0	0.1	0.2	0.3	0.4	0.5	0.6	0.7	0.8	0	0.1	0.2	0.3	0.4	0.5	0.6	0.7	0.8	0.9	1.0	
“+” (Plus) SETTING (“Adjust” Jumper at “+” Setting)																					
“COOL” Speed	Tap D	65	90	110	135	155	179	207	228	246	170	196	225	258	286	318	347	380	404	427	456
	Tap C	92	120	142	172	196	223	251	274	301	257	286	321	360	391	424	452	484	515	549	585
	Tap B	138	162	197	221	251	280	303	334	360	344	379	418	457	494	529	567	602	642	674	713
	Tap A	191	220	251	284	312	343	372	401	434	499	539	580	625	661	696	742	783	823	866	902
“NORM” (Normal) SETTING (“Adjust” Jumper at “NORM” Setting)																					
“COOL” Speed	Tap D	49	72	94	117	141	160	184	207	231	122	147	177	207	231	261	289	310	342	366	399
	Tap C	76	98	126	147	172	196	223	244	267	183	210	244	276	306	334	362	395	422	453	486
	Tap B	109	134	160	187	211	237	261	289	313	267	296	334	369	405	434	474	506	538	568	600
	Tap A	146	176	200	232	258	287	317	345	370	380	411	457	488	531	565	597	638	672	705	748
“—” (Minus) SETTING (“Adjust” Jumper at “—” Setting)																					
“COOL” Speed	Tap D	37	54	83	103	123	147	166	187	206	89	113	138	169	193	217	246	270	293	320	343
	Tap C	58	79	103	127	149	175	193	215	239	140	166	198	228	251	280	310	340	364	396	419
	Tap B	85	105	136	159	184	207	230	256	278	202	231	266	294	325	359	392	419	447	480	514
	Tap A	103	129	154	185	211	237	263	290	312	285	316	349	386	423	453	490	519	552	583	614

ML296UHV PARTS IDENTIFICATION

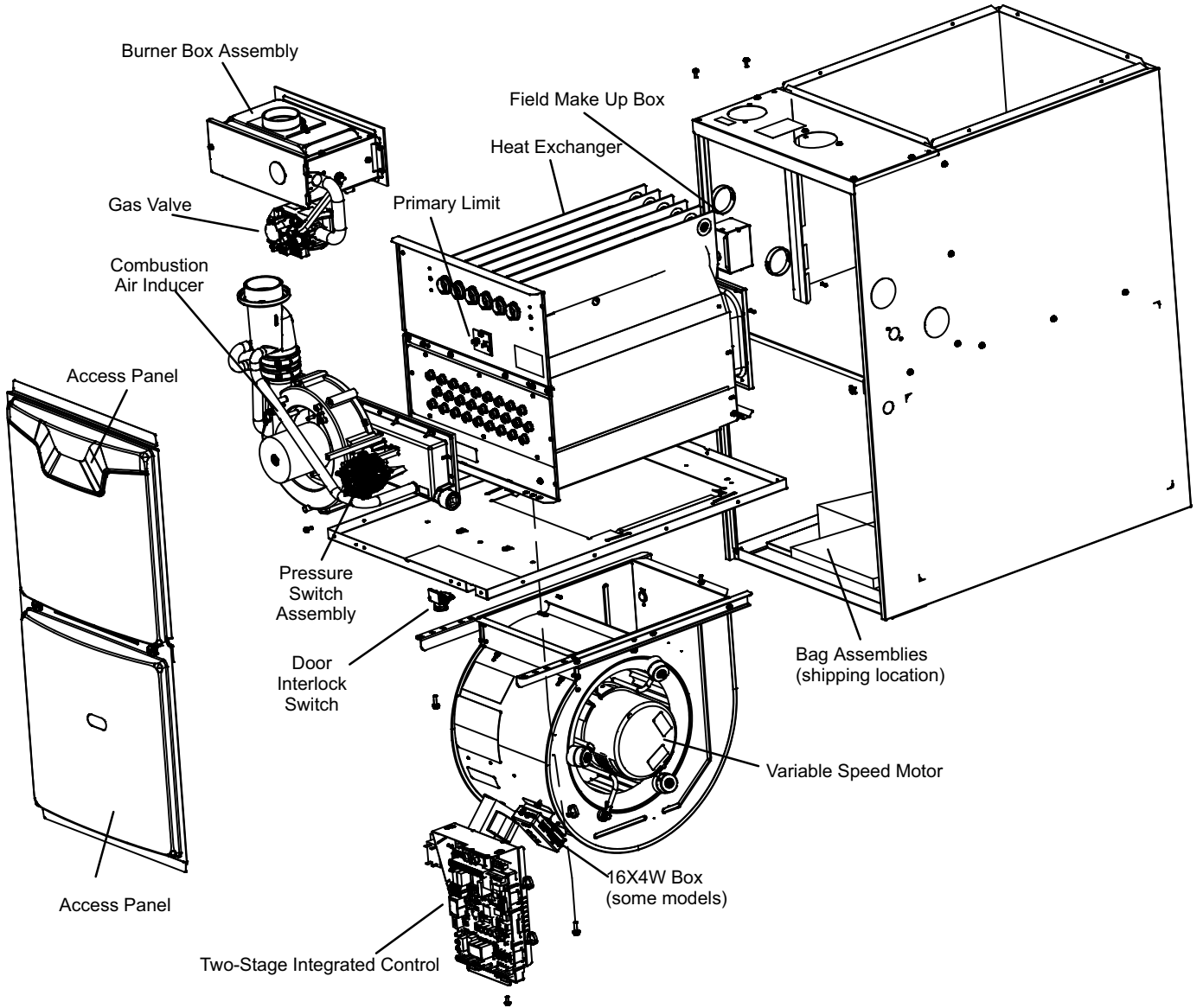

FIGURE 1

I-UNIT COMPONENTS

ML296UHV(X) unit components are shown in figure 1. The gas valve, combustion air inducer and burners can be accessed by removing the access panel. Electrical components are in the control box (figure 2) found in the blower section.

⚠ CAUTION



Electrostatic discharge can affect electronic components. Take precautions to neutralize electrostatic charge by touching your hand and tools to metal prior to handling the control.

A- Control Box

1. Control Transformer (T1)

A transformer located in the control box provides power to the low voltage section of the unit. Transformers on all models are rated 40VA with a 120V primary and a 24V secondary.

2. Door Interlock Switch (S51)

A door interlock switch rated 14A at 125VAC is wired in series with line voltage. When the inner blower access panel is removed the unit will shut down.

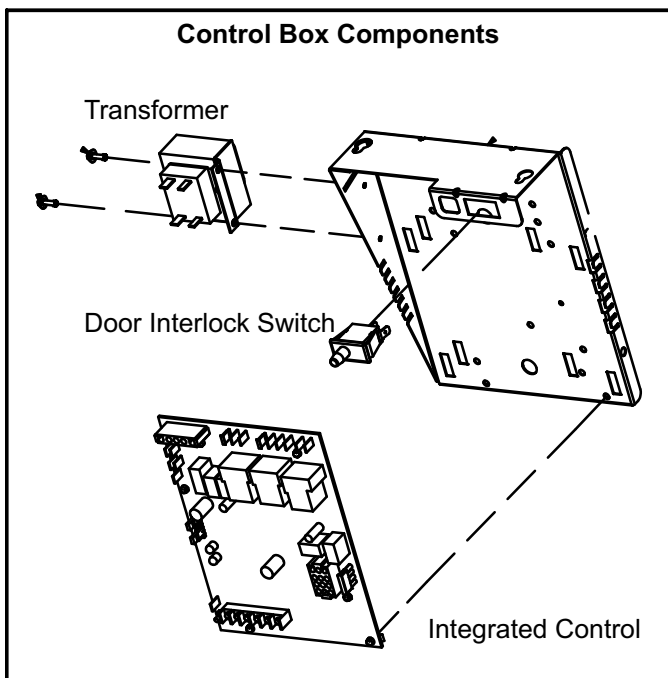

FIGURE 2

⚠ WARNING

Shock hazard.
Disconnect power before servicing. Integrated control is not field repairable. If control is inoperable, simply replace entire control.
Can cause injury or death. Unsafe operation will result if repair is attempted.

3. Integrated Control (A92)

Units are equipped with a two-stage, variable speed integrated control. The system consists of a ignition / blower control (figure 3) with control pin designations in tables 3 and 4 and ignitor. The control and ignitor work in combination to ensure furnace ignition and ignitor durability. The control provides gas ignition, safety checks and indoor blower control with two-stage gas heating. The furnace combustion air inducer, gas valve and indoor blower are controlled in response to various system inputs such as thermostat signal, pressure and limit switch signal and flame signal.

The furnace has a built-in, self-diagnostic capability. If a system problem occurs, a fault code is shown by a **red** LED on the control. The control continuously monitors its own operation and the operation of the system. If a failure occurs, the LED will indicate the failure code. The flash codes are presented in table 2.

Fault Code History Button

The control stores the last five fault codes in memory. A pushbutton switch is located on the control. When the pushbutton switch is pressed and released, the control flashes the stored fault codes. The most recent fault code is flashed first; the oldest fault code is flashed last. To clear the fault code history, press and hold the pushbutton switch in for more than 5 seconds before releasing.

Single Stage Thermostat Operation

The automatic heat staging option allows a single stage thermostat to be used with two stage furnace models. To activate this option, move the jumper pin (see Figure 3) to desired setting (5 minutes or 10 minutes). The furnace will start on 1st stage heat and stay at 1st stage heat for the duration of the selected time before switching to 2nd stage heat.

W1 on the integrated control must be connected to W1 on the thermostat.

High Heat State LED

A **green** LED is provided on the control board to indicate high heat state (see Table 1).

CFM LED

An amber LED is provided on the control board to display CFM. To determine what CFM the motor is delivering at any time, count the number of times the amber LED flashes. Each flash signifies 100 CFM; count the flashes and multiply by 100 to determine the actual CFM delivered (for example: 5 flashes x 100 = 500 CFM).

TABLE 1

High Heat State Green LED	
LED Status	DESCRIPTION
LED Off	No demand for high heat
LED On	High heat demand, operating normally
LED Flashing	High heat demand, high pressure switch not closed

TABLE 2

Diagnostic Codes Red LED	
LED Status	DESCRIPTION
LED Off	No power to control or control hardware fault detected.
LED On	Normal operation.
1 Flash	Flame present with gas valve de-energized.
2 Flashes	Pressure switch closed with combustion air inducer de-energized.
3 Flashes	Low-fire pressure, rollout or limit switch open.
4 Flashes	Primary limit switch open.
5 Flashes	Not used
6 Flashes	Pressure switch cycle lockout.
7 Flashes	Lockout, burners fail to light.
8 Flashes	Lockout, burners lost flame too many times.
9 Flashes	Line voltage polarity incorrect.

TABLE 3

Control 5 Pin Terminal Designation	
PIN #	Function
1	Ignitor (Hot)
2	Combustion Air Inducer High Speed
3	Combustion Air Inducer Low Speed
4	Combustion Air Inducer Neutral
5	Ignitor Neutral

Airflow Adjustments

Cooling Mode

The units are factory set for the highest airflow for each model. Adjustments can be made to the cooling airflow by repositioning the jumper plug marked COOL – A, B, C, D (see Figure 3). To determine what CFM the motor is delivering at any time, count the number of times the amber LED on the control board flashes. Each flash signifies 100 CFM; count the flashes and multiply by 100 to determine the actual CFM delivered (for example: 5 flashes x 100 = 500 CFM).

TABLE 4

12 Pin Terminal Designation	
PIN #	Function
1	Gas Valve Second Stage
2	Second Stage Prove Switch
3	Rollout Switch In
4	Ground
5	24V Hot
6	Primary Limit In
7	Gas Valve First Stage
8	Gas Valve Common
9	24V Neutral
10	Ground
11	Rollout Switch Out
12	First Stage Prove Switch

Heating Mode

These units are factory set to run at the middle of the heating rise range as shown on the unit rating plate. If higher or lower rise is desired, reposition the jumper plug marked HEAT - A, B, C, D (see Figure 3) . To determine what CFM the motor is delivering at any time, count the number of times the amber LED on the control board flashes. Each flash signifies 100 CFM; count the flashes and multiply by 100 to determine the actual CFM delivered (for example: 5 flashes x 100= 500).

Adjust Tap

Airflow amounts may be increased or decreased by 10% by moving the ADJUST jumper plug (see Figure 3) from the NORM position to the (+) or (-) position. Changes to the ADJUST tap will affect both cooling and heating airflows. The TEST position on the ADJUST tap is not used.

Continuous Blower Operation

The comfort level of the living space can be enhanced when using this feature by allowing continuous circulation of air between calls for cooling or heating. The circulation of air occurs at half the full cooling airflow rate.

To engage the continuous blower operation, place the fan switch on the thermostat into the ON position. A call for fan from the thermostat closes R to G on the ignition control board. The control waits for a 1 second thermostat delay before responding to the call for fan by ramping the circulating blower up to 50% of the cooling speed. When the call for continuous fan is satisfied, the control immediately ramps down the circulating blower.

INTEGRATED CONTROL

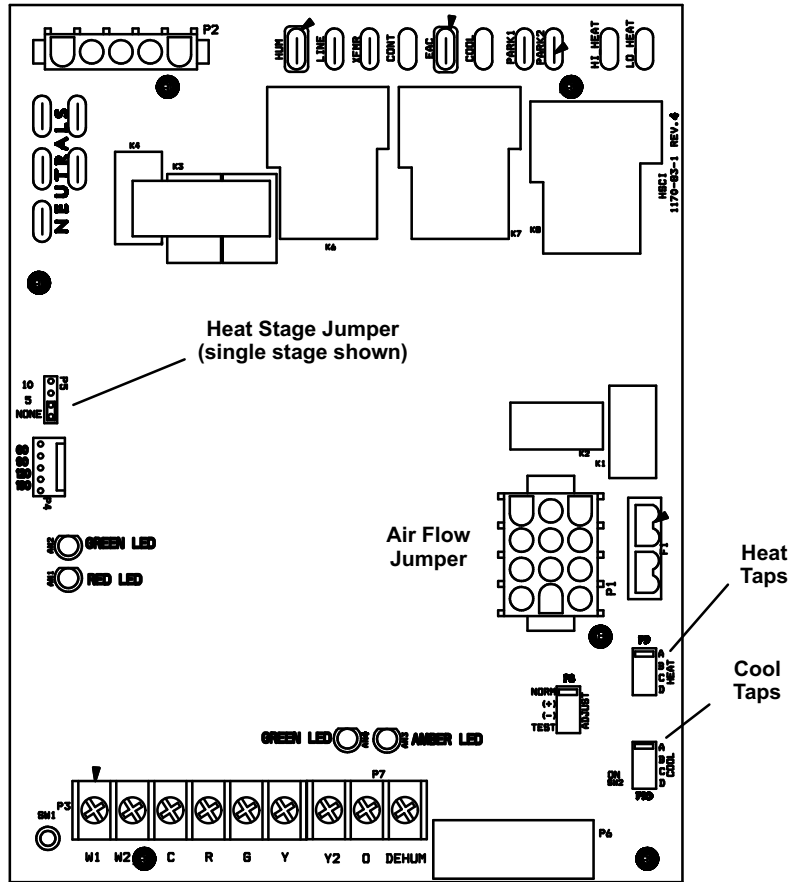

TERMINAL DESIGNATIONS

- HUM -Humidifier (120VAC)
- Line - Input (120VAC)
- XFMR - Transformer (120VAC)
- EAC - Indoor Air Accessory (120VAC)
- Cool - Cool Speed (120VAC)
- Park 1 - Dead terminal for alternate speed tap
- Park 2 - Dead terminal for alternate speed tap

FIGURE 3

B- Indoor Blower Motor

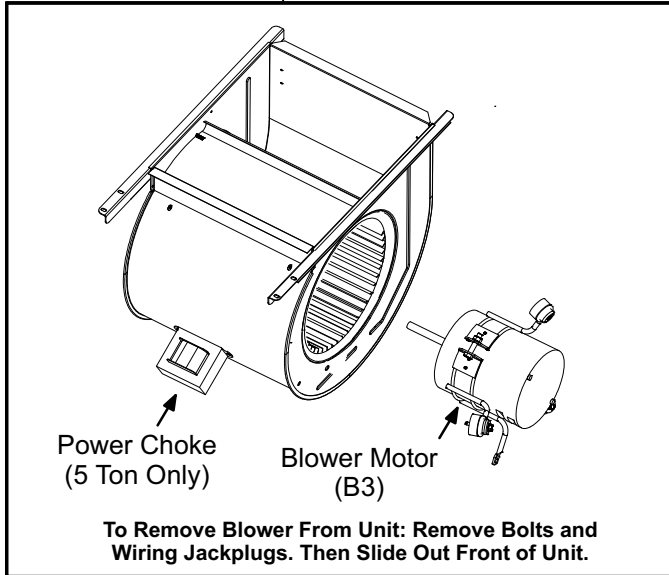

FIGURE 4

Blower Motor (B3)

Blower motors are manufactured by GenTeq and Nidec/Emerson. See figures 6 and 7. Motors operate the same and are only different in physical appearance. They are both three-phase, electronically controlled DC brushless motors (controller converts single-phase AC to three-phase DC), with a permanent magnet type rotor (figure 6). Because these motors have a permanent magnet rotor it does not need brushes like conventional DC motors.

Internal components for both manufactured motors are similar and shown in figure. The stator windings are split into three poles which are electrically connected to the controller. This arrangement allows motor windings to turn on and off in sequence by the controller.

A solid-state controller is attached to the motor. The controller is primarily an AC to DC converter. Converted DC power is used to drive the motor. The controller contains a microprocessor which monitors varying conditions inside the motor (such as motor workload). The controller on the NIDEC / Emerson motor includes the 16X4W control with three LED's PW, RX and TX located on the face for troubleshooting. Some models have the 16X4W located on the blower housing. Figures 7 and 8 show the location of the 16X4W and table 5 the LED codes.

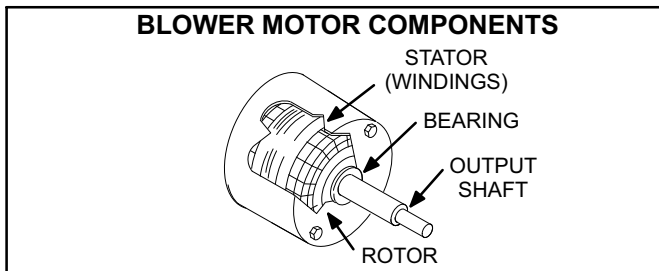

FIGURE 5

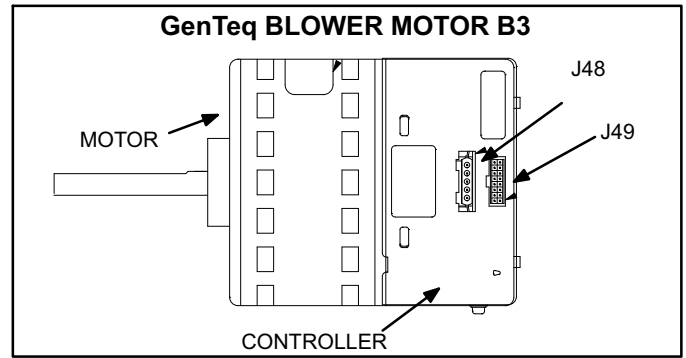

FIGURE 6

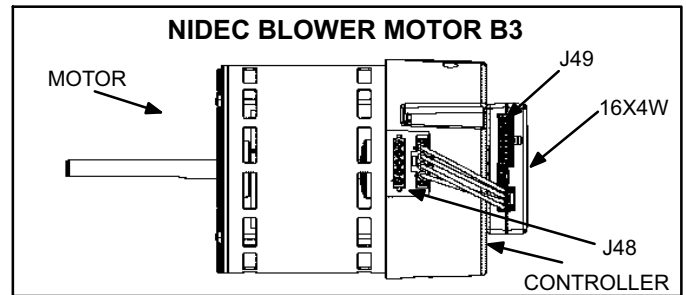

FIGURE 7

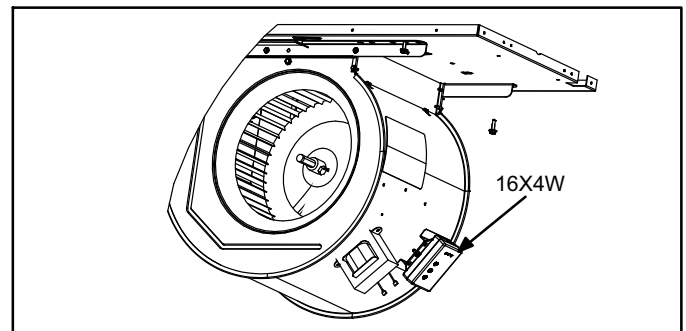

FIGURE 8

The controller uses sensing devices to sense what position the rotor is in at any given time. By sensing the position of the rotor and then switching the motor windings on and off in sequence, the rotor shaft turns the blower.

All blower motors use single phase power. An external run capacitor is not used. The motor uses permanently lubricated ball-type bearings.

Internal Operation

Each time the controller switches a stator winding (figure 5) on and off, it is called a "pulse." The length of time each pulse stays on is called the "pulse width." By varying the pulse width (figure 11), the controller varies motor speed (called "pulse-width modulation"). This allows for precise control of motor speed and allows the motor to compensate for varying load conditions as sensed by the controller. In this case, the controller monitors the static workload on the motor and varies motor rpm in order to maintain constant airflow (cfm).

**TABLE 5
NIDEC / Emerson Motor Only**

PW LED	RX LED	TX LED	Motor Blower	Action
Off	Blink	Blink	Not Rotating	Normal
Blink	Blink	Blink	Rotating	Normal. PW blink is 100cfm/blink
Blink	Off	Blink	Not Rotating	Verify 16X4W and motor control hp match. Verify power to motor control. Turn off power for 1 minute then restart. If motor still does not rotate replace the controller.
Off	Off	Off	Not Rotating	Verify power to the 16X4W. Turn off power then restart. If LED's are still out, replace controller.

Motor rpm is continually adjusted internally to maintain constant cfm. The controller monitors the static work load on the motor and motor amp-draw to determine the amount of rpm adjustment. Blower rpm may be adjusted any amount in order to maintain a constant cfm as shown in Blower Ratings Tables. The cfm remains relatively stable over a broad range of static pressure. Since the blower constantly adjusts rpm to maintain a specified cfm, motor rpm is not rated. Hence, the terms “cool speed”, “heat speed” or “speed tap” in this manual, on the unit wiring diagram and on blower B3, refer to blower cfm regardless of motor rpm.

The unit control indicates the desired cfm. The blower will maintain the desired cfm as long as external static pressure does not exceed 0.8". If the system exceeds this amount, the blower *may* enter a “cut back”, mode wherein it then slows down to protect itself from electrical damage. During this “cut back” mode the unit control will still indicate the *same* desired cfm regardless of actual motor rpm.

When Harmony is used, speed taps are overridden and a PWM signal generated by the Harmony controller continuously varies motor speed based upon zone demands.

Initial Power Up

When line voltage is applied to B3, there will be a large inrush of power lasting less than 1/4 second. This inrush charges a bank of DC filter capacitors inside the controller. If the disconnect switch is bounced when the disconnect is closed, the disconnect contacts may become welded. Try not to bounce the disconnect switch when applying power to the unit.

Motor Start-Up

When B3 begins start-up, the motor gently vibrates back and forth for a moment. This is normal. During this time the electronic controller is determining the exact position of the rotor. Once the motor begins turning, the controller slowly eases the motor up to speed (this is called “soft-start”). The motor may take as long as 10-15 seconds to reach full speed. If the

motor does not reach 200rpm within 13 seconds, the motor shuts down. Then the motor will immediately attempt a restart. The shutdown feature provides protection in case of a frozen bearing or blocked blower wheel. The motor may attempt to start eight times. If the motor does not start after the eighth try, the controller locks out. Reset controller by momentarily turning off power to unit.

The DC filter capacitors inside the controller are connected electrically to the speed tap wires. The capacitors take approximately 5 minutes to discharge when the disconnect is opened. For this reason it is necessary to wait at least 5 minutes after turning off power to the unit before attempting to change speed taps.

⚠ DANGER	
	<p>Disconnect power from unit and wait at least five minutes to allow capacitors to discharge before attempting to adjust motor speed tap settings. Failure to wait may cause personal injury or death.</p>

External Operation (Speed Tap Priority)

Figures 9 and 10 show the two quick-connect jacks (J48 and J49) which connect the motor to the ML296UHV. Jack J48 is the power plug and jack J49 connects the unit controls to the motor.

Jack J48 is the power plug. Line voltage must be applied to J48 pins 4 and 5 in order for the motor to operate. When using 120VAC pins 1 and 2 must be jumpered.

Jack J49 connects the unit controls to the motor. The motor assigns priority to J49 pin 2 so that if a call for cooling and a call for heating are concurrent, heating call overrides and the blower operates on high speed heating tap.

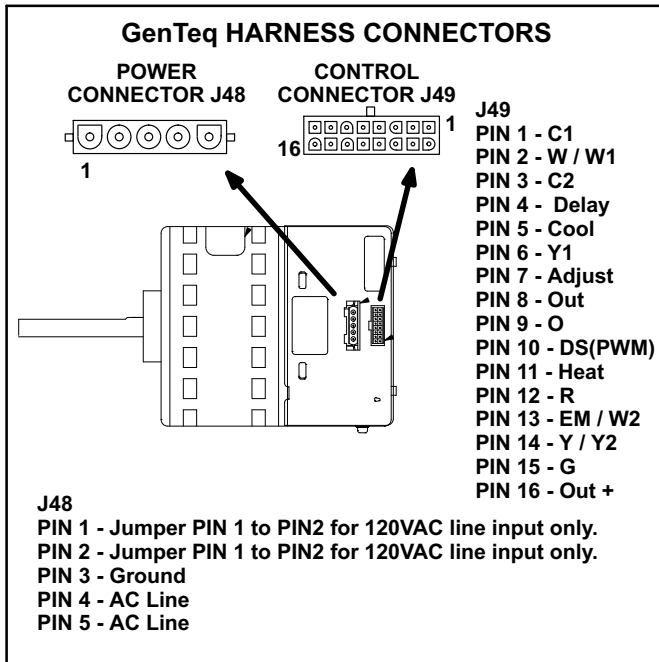

FIGURE 9

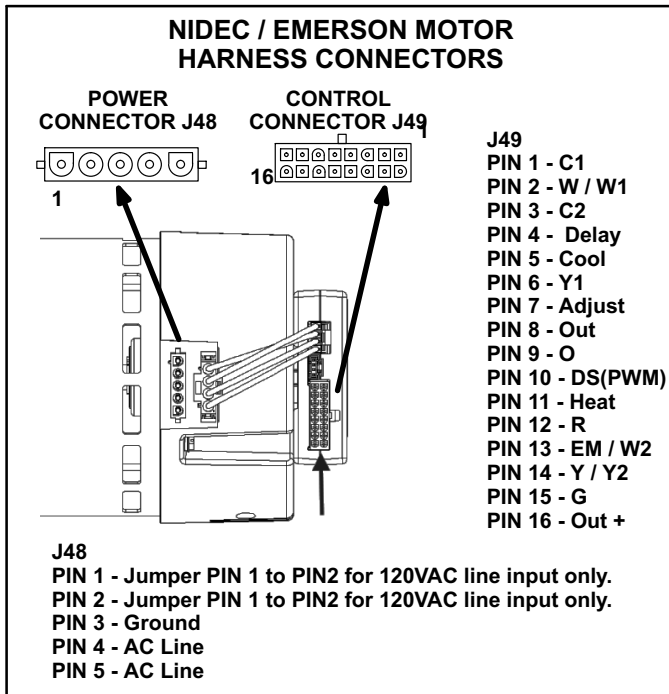

FIGURE 10

Power Choke (L13)

A choke coil is used on 5 ton 1 hp units. The choke is located on the blower housing and is used to suppress transient current spikes.

Precautions



If the furnace or its electronically controlled blower motor is improperly or inadequately grounded, it may cause television interference (commonly known as RFI or radio frequency interference).

This interference is caused by internal switching frequencies of the motor controller. TV interference may show up as small specks or lines which randomly appear on the TV screen accompanied by pops or clicks in the sound. Before attempting any service, make sure the indoor unit is causing the interference. To check, disconnect power to indoor unit then check TV for continued signs of interference.

TV interference may be stopped by making sure the motor is solidly grounded to the cabinet (metal to metal) and by making sure the cabinet is solidly grounded. If TV interference persists, make sure the television (and all affected RF appliances) are moved away from the furnace. Also make sure affected appliances are connected to a separate electrical circuit.

MOTOR SPEED CONTROL WITH D.C. PULSE-WIDTH MODULATION

Motor speed is determined by the size of the electrical pulse sent to the motor windings. The longer the pulse, the faster the motor.

OUTPUT FROM CONTROLLER TO MOTOR WINDINGS	
WINDINGS TURNED OFF	WINDINGS TURNED ON
	 ON PULSE  OFF PULSE

The frequency of the pulses to the windings is 20KHz.
DO NOT ATTEMPT TO MEASURE THESE VOLTAGES.

LOW SPEED HEAT/COOL (output from controller to motor windings)

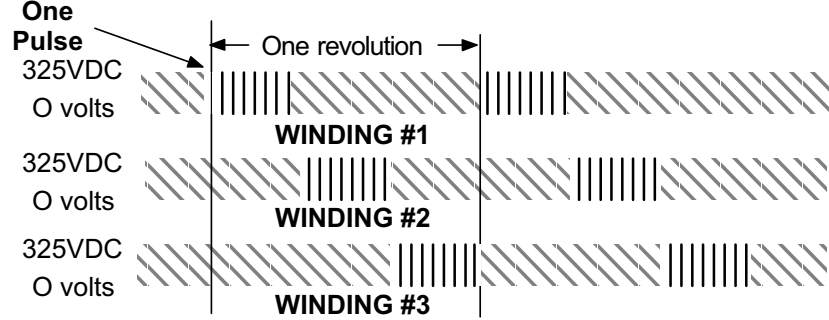

HIGH SPEED HEAT (output from controller to motor windings)

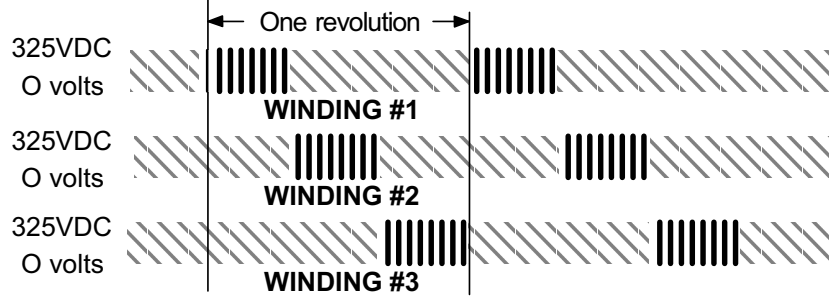

HIGH SPEED COOL (output from controller to motor windings)

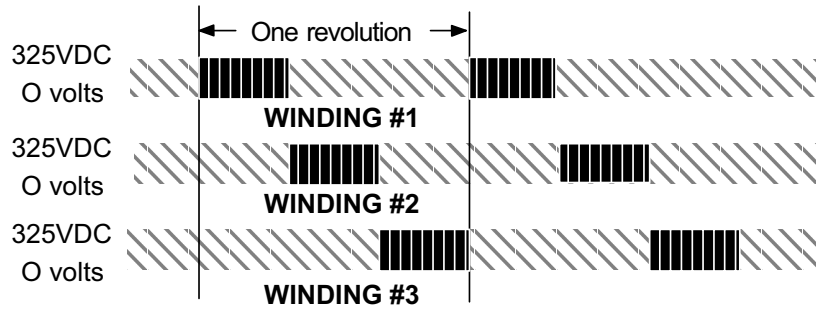

FIGURE 11

C- Heating Components

1. Ignitor

The ignitor is made of durable silicon nitride. Ignitor longevity is enhanced by controlling voltage to the ignitor. The integrated control provides a regulated 120 volts to the ignitor for a consistent ignition and long ignitor life. Ohm value should be 39 to 70. See figure 12 for ignitor location and figure 13 for ignitor check out.

NOTE - The ML296UHV(X) furnace contains electronic components that are polarity sensitive. Make sure that the furnace is wired correctly and is properly grounded.

2. Flame Sensor

A flame sensor is located on the left side of the burner support. See figure 12. The sensor tip protrudes into the flame envelope of the left-most burner. The sensor can be removed for service without removing any part of the burners. During operation, flame is sensed by current passed through the flame and sensing electrode. The SureLight control allows the gas valve to remain open as long as flame signal is sensed. See table 6 for flame signal.

TABLE 6
Flame Signal in Microamps

Normal	Low	Drop Out
1.5 or greater	1.0 or less	0.5

3. Gas Valve

The valve (figure 50) is internally redundant to assure safety shut-off. If the gas valve must be replaced, the same type valve must be used.

24VAC terminals and gas control knob are located on the valve. A wire harness connects the terminals from the gas valve to the electronic ignition control. 24V applied to the terminals energizes the valve.

Inlet and outlet pressure taps are located on the valve. A regulator adjustment screw is located on the valve.

LPG change over kits are available from Lennox. Kits include burner orifices and a gas valve.

4. Flame Rollout Switches (S47)

Flame rollout switch is a high temperature limit located on top of the burner box, one on each side.- See figure 12. The limit is a N.C. SPST manual-reset limit. When S47 senses rollout, the circuit breaks and the ignition control immediately stops ignition and closes the gas valve. Rollout can be caused by a blocked heat exchanger, flue or lack of combustion air. The switch is factory set to trip (open) at 210°F and cannot be adjusted. The switch can be manually reset. To manually reset a tripped switch, push the reset button located on the control.

5. Burners

All units use inshot burners. Burners are factory set and require no adjustment. Always operate the unit with the burner box front panel in place. Each burner uses an orifice (see table 21 for orifice size) that is precisely matched to the burner input. Burners can be removed as a one piece assembly for service. If burner assembly has been removed, it is critical to align center of each burner to the center of the clamshell when re-installing. See more detail in Section VI- MAINTENANCE.

6. Primary Limit Control (S10)

The primary limit (S10) is located in the heating vestibule panel. When excess heat is sensed in the heat exchanger, the limit will open. If the limit is open, the furnace control energizes the supply air blower and closes the gas valve. The limit automatically resets when unit temperature returns to normal. The switch must reset within three minutes or the SureLight control will go into Watch guard for one hour. The switch is factory set and cannot be adjusted. The switch may have a different set point for each unit model number. See Lennox Repair Parts Handbook if limit switch must be replaced,

ML296UHV HEATING COMPONENTS

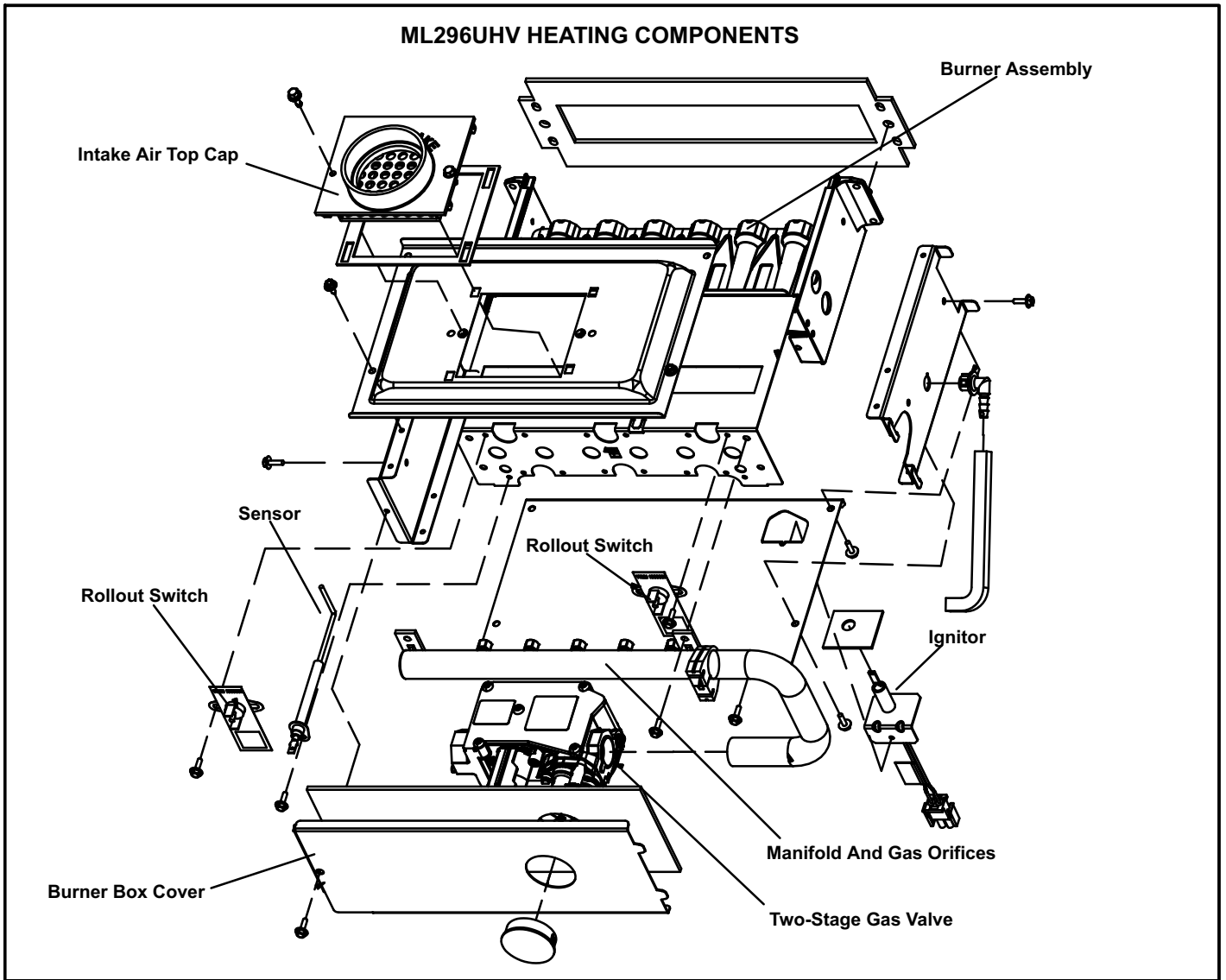

FIGURE 12

ML296UHV Ignitor Check

Test 1

Check ignitor circuit for correct resistance.

Remove 4-pin plug from control.
Check ohms reading across terminals 1 and 5.
Reading should be between 39 and 70 ohms. If value is correct, this is the only test needed.
If the reading on the meter is not correct, (0 or infinity) then a second test is needed.

Meter
(set to ohms)

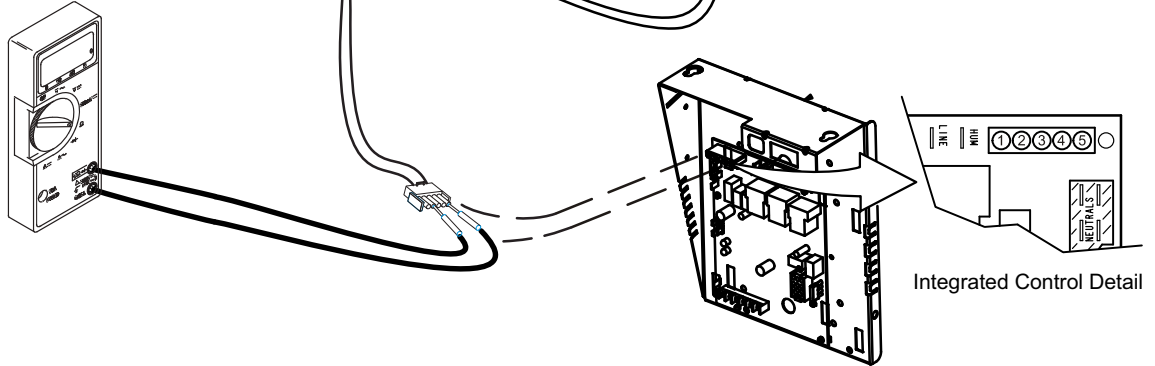

Test 2

Check ignitor for correct resistance.

Separate the 2-pin jack-plug near the manifold and check resistance of ignitor at the plug. Reading should be between 39 and 70 ohms. If the reading is correct, then the problem is with the wiring between the jack-plug and the control. If reading is not correct, the issue is the ignitor.

Meter
(set to ohms)

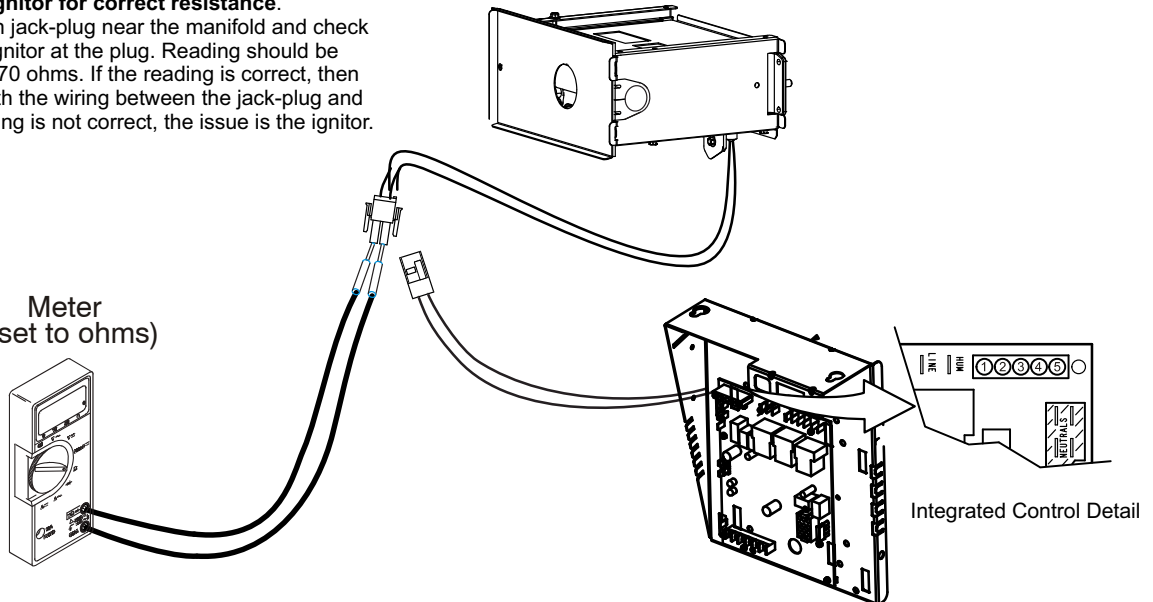

Test 3

Check ignitor for correct voltage

Insert meter probes into terminals 1 and 5 (use small diameter probes in order not to damage plug).
Check voltage during 20 second ignitor warm up period.
Voltage should read 120 volts \pm 10%. If voltage reads below these values, check for correct supply voltage to furnace.

Meter
(set to AC volts)

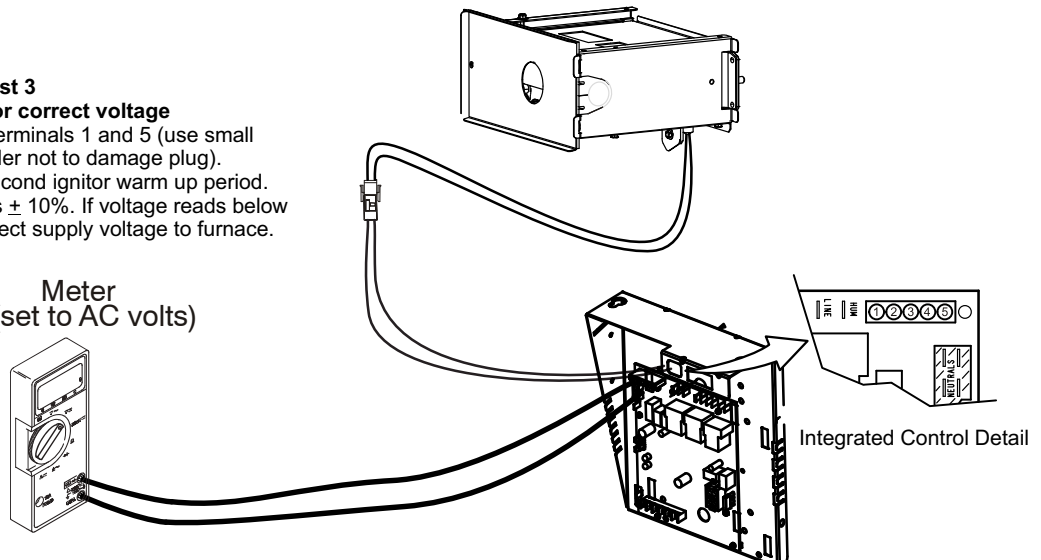

FIGURE 13

7. Combustion Air Inducer (B6) and Cold End Header Box

All ML296UHV(X) units use a two-stage combustion air inducer to move air through the burners and heat exchanger during heating operation. The blower uses a 120VAC motor. The motor operates during all heating operation and is controlled by integrated control control A92. The inducer also operates for 15 seconds before burner ignition (pre-purge) and for 5 seconds after the gas valve closes (post-purge). The inducer operates on low speed during first-stage heat, then switches to high speed for second stage heat.

NOTE - Each furnace model uses a unique CAI. Refer to Lennox Repair Parts listing for correct inducer for replacement.

The combustion air inducer is installed on the cold end header box. The cold end header box is a single piece made of hard plastic. The box has an internal channel where the combustion air inducer creates negative pressure at unit start up. The channel contains an orifice used to regulate flow created by the combustion air inducer. The box has pressure taps for the combustion air inducer pressure switch hoses. The pressure switch measures the pressure differential across the combustion air inducer orifice or difference in the channel and the box. **If replacement is necessary the gaskets used to seal the box to the vestibule panel and the combustion air inducer to the box, must also be replaced.**

A proving switch connected to the combustion air inducer orifice plate is used to prove inducer operation. The combustion air inducer orifice will be different for each model. See table 7 for orifice sizes. The pressure switch measures the pressure differential across the combustion air inducer orifice. When the proving switch opens, the furnace control (A92) immediately closes the gas valve to prevent burner operation.

TABLE 7

ML296UHV(X) Unit	C.A.I. Orifice Size
-045	0.700
-070	0.920
-090	1.100
-110	1.155

8. Combustion Air Inducer Pressure Switch (S18)

ML296UHV(X) series units are equipped with a dual combustion air pressure switch (first and second stage) located on the combustion air inducer orifice bracket. See figure 14. The switch is connected to the combustion air inducer housing by means of a flexible silicone hose. It monitors negative air pressure in the combustion air inducer housing.

The switches are a single-pole single-throw proving switch electrically connected to the integrated control. The purpose of the switch is to prevent burner operation if the combustion air inducer is not operating or if the flue becomes obstructed.

On heat demand (first or second stage) the switch senses that the combustion air inducer is operating. It closes a circuit to the integrated control when pressure inside the combustion air inducer decreases to a certain set point. Set points vary depending on unit size. See table 8. The pressure sensed by the switch is negative relative to atmospheric pressure. If the flue becomes obstructed during operation, the switch senses a loss of negative pressure (pressure becomes more equal with atmospheric pressure) and opens the circuit to the furnace control and gas valve. A bleed port on the switch allows relatively dry air in the vestibule to purge switch tubing, to prevent condensate build up.

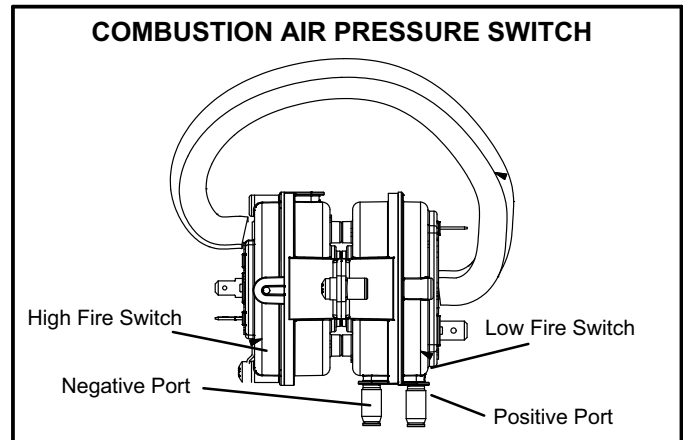

FIGURE 14

NOTE - The switch is factory set and is not field adjustable. It is a safety shut-down control in the furnace and must not be by-passed for any reason. If switch is closed or by-passed, the control will not initiate ignition at start up.

TABLE 8 0 - 4500'

ML296UHV(X) Unit	Set Point Low Heat	Set Point High Heat
-045	0.40	0.70
-070	0.50	0.85
-090	0.50	0.85
-110	0.50	0.90

TABLE 9 4501 - 7500'

ML296UHV(X) Unit	Set Point Low Heat	Set Point High Heat
-045	0.35	0.55
-070	0.45	0.75
-090	0.50	0.85
-110	0.45	0.81

TABLE 10 7501 - 10,000'

ML296UHV(X) Unit	Set Point Low Heat	Set Point High Heat
-045	0.35	0.50
-070	0.40	0.70
-090	0.45	0.81
-110	0.41	0.74

Pressure Switch Check

To check pressure switch differential, refer to figure 15 and use the provided fittings and tubing to follow the steps below.

- 1 - Remove thermostat demand and allow unit to cycle off.
- 2 - Remove the tubing from the negative side (red and black or red) and positive side (black) of the pressure switch (leave both connected to cold end header box).
- 3 - Take the 2" length square tubing and connect to the positive (+) side of the pressure switch. Take the 10" length square tubing and tee into the tubing from the positive side of the cold end header box and the other side of the 2" square tubing. Connect the other end of the 10" square tubing to the positive (+) side of the measuring device.
- 4 - Take a second piece the 2" length square tubing and connect to the negative (-) side of the pressure switch. Take a second piece of 10" length square tubing and tee into the tubing from the negative (-) side of the cold end header box and the other side of the 2" square tubing. Connect the other end of the 10" square tubing to the negative (-) side of the measuring device.

- 5 - Operate unit and observe manometer reading.
Readings will change as heat exchanger warms.
 - a. Take one reading immediately after start-up.
 - b. Take a second reading after unit has reached steady state (approximately 5 minutes). This will be the pressure differential.

The pressure differential should be at least 0.15" greater than those listed in the tables 8, 9 and 10. Readings in table are the set points or "break points".

- 6 - Remove thermostat demand and allow to cycle off.
- 7 - Replace original pressure switch tubing.

NOTE - Pressure differential values (set point) in table are the "break", or "open" specifications. "Make", or "close" pressure differentials are 0.15" greater than the set points listed in table.

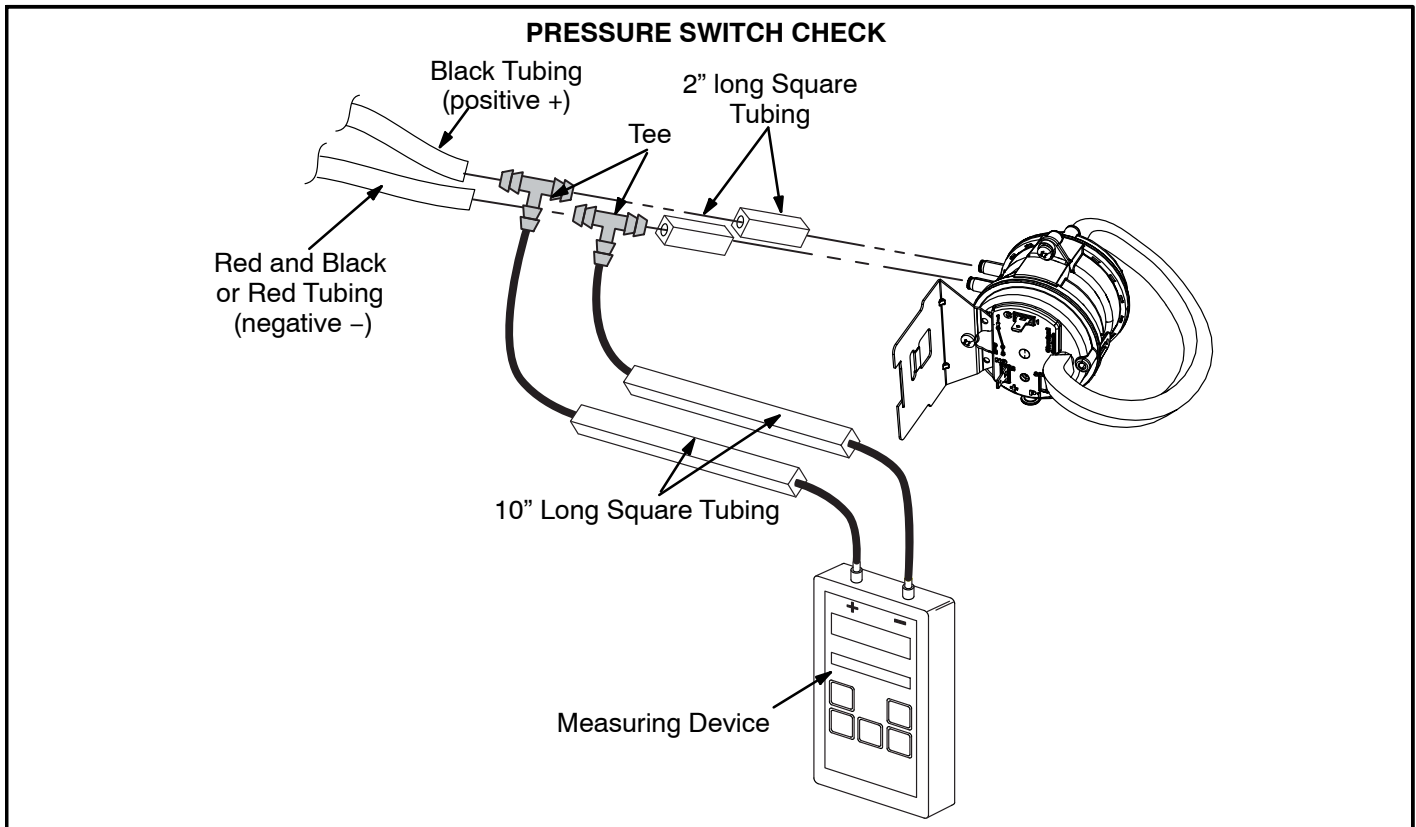

FIGURE 15

II-PLACEMENT AND INSTALLATION

All pipe, fittings, primer and solvent cement must conform with American National Standard Institute and the American Society for Testing and Materials (ANSI/ASTM) standards. The solvent shall be free flowing and contain no lumps, undissolved particles or any foreign matter that adversely affects the joint strength or chemical resistance of the cement. The cement shall show no gelation, stratification, or separation that cannot be removed by stirring. Refer to the table 11 below for approved piping and fitting materials.

⚠ CAUTION
Solvent cements for plastic pipe are flammable liquids and should be kept away from all sources of ignition. Do not use excessive amounts of solvent cement when making joints. Good ventilation should be maintained to reduce fire hazard and to minimize breathing of solvent vapors. Avoid contact of cement with skin and eyes.

Low temperature solvent cement is recommended during cooler weather. Metal or plastic strapping may be used for vent pipe hangers. Uniformly apply a liberal coat of PVC primer for PVC or use a clean dry cloth for ABS to clean inside socket surface of fitting and male end of pipe to depth of fitting socket.

Canadian Applications Only - Pipe, fittings, primer and solvent cement used to vent (exhaust) this appliance must be certified to ULC S636 and supplied by a single manufacturer as part of an approved vent (exhaust) system. In addition, the first three feet of vent pipe from the furnace flue collar must be accessible for inspection.

**TABLE 11
PIPING AND FITTINGS SPECIFICATIONS**

Schedule 40 PVC (Pipe)	D1785
Schedule 40 PVC (Cellular Core Pipe)	F891
Schedule 40 PVC (Fittings)	D2466
Schedule 40 CPVC (Pipe)	F441
Schedule 40 CPVC (Fittings)	F438
SDR-21 PVC or SDR-26 PVC (Pipe)	D2241
SDR-21 CPVC or SDR-26 CPVC (Pipe)	F442
Schedule 40 ABS Cellular Core DWV (Pipe)	F628
Schedule 40 ABS (Pipe)	D1527
Schedule 40 ABS (Fittings)	D2468
ABS-DWV (Drain Waste & Vent) (Pipe & Fittings)	D2661
PVC-DWV (Drain Waste & Vent) Pipe & Fittings)	D2665
PRIMER & SOLVENT CEMENT	ASTM SPECIFICATION
PVC & CPVC Primer	F656
PVC Solvent Cement	D2564
CPVC Solvent Cement	F493
ABS Solvent Cement	D2235
PVC/CPVC/ABS All Purpose Cement For Fittings & Pipe of the same material	D2564, D2235, F493
ABS to PVC or CPVC Transition Solvent Cement	D3138
CANADA PIPE & FITTING & SOLVENT CEMENT	MARKING
PVC & CPVC Pipe and Fittings	ULCS636
PVC & CPVC Solvent Cement	
ABS to PVC or CPVC Transition Cement	
POLYPROPYLENE VENTING SYSTEM	
PolyPro® by Duravent	ULC-S636
InnoFlue® by Centrotherm	ULC-S636

⚠ IMPORTANT
ML296UHV exhaust and intake connections are made of PVC. Use PVC primer and solvent cement when using PVC vent pipe. When using ABS vent pipe, use transitional solvent cement to make connections to the PVC fittings in the unit.

Use PVC primer and solvent cement or ABS solvent cement meeting ASTM specifications, refer to Table 11. As an alternate, use all purpose cement, to bond ABS, PVC, or CPVC pipe when using fittings and pipe made of the same materials. Use transition solvent cement when bonding ABS to either PVC or CPVC.

**TABLE 12
OUTDOOR TERMINATION USAGE***

Input Size	Vent Pipe Dia. in.	STANDARD					CONCENTRIC		
		Flush-Mount Kit	Wall Kit		Wall Ring Kit	Field Fabricated	1-1/2 inch	2 inch	3 inch
			2 inch	3 inch	2 inch				
		51W11 (US) 51W12 (CA)	22G44 (US) 430G28 (CA)	44J40 (US) 481J20 (CA)	15F74		71M80 (US) 444W92 (CA)	69M29 (US) 444W92 (CA)	60L46 (US) 444W93 (CA)
045	61-1/2	³ YES	YES	¹ YES	¹ YES	⁵ YES	² YES		
	2	³ YES	YES	¹ YES	¹ YES	⁵ YES	² YES		
	2-1/2	³ YES	YES	¹ YES	¹ YES	⁵ YES	² YES		
	3	³ YES	YES	¹ YES	¹ YES	⁵ YES	² YES		
070	2	³ YES	YES	¹ YES	¹ YES	⁵ YES	² YES		
	2-1/2	³ YES	YES	¹ YES	¹ YES	⁵ YES	² YES		
	3	³ YES	YES	¹ YES	¹ YES	⁵ YES	² YES		
090	2	³ YES		YES	YES	⁵ YES		YES	YES
	2-1/2	³ YES		YES	YES	⁵ YES		YES	YES
	3	³ YES		YES	YES	⁵ YES		YES	YES
110	2	YES		YES	YES	⁵ YES		YES	YES
	2-1/2	YES		YES		⁵ YES		YES	YES
	3	YES		YES		⁵ YES		YES	YES

NOTE - Standard Terminations do not include any vent pipe or elbows external to the structure. Any vent pipe or elbows external to the structure must be included in total vent length calculations. See vent length tables.

** Kits must be properly installed according to kit instructions.*

¹Requires field-provided outdoor 1-1/2" exhaust accelerator.

²Concentric kits 71M80 and 44W92 include 1-1/2" outdoor accelerator, when used with 045 and 070 input models. 1-1/2 in pipe must transitioned to 2in pipe when used with a concentric kit

³Flush mount kits 51W11 and 51W12 includes 1-1/2 in. outdoor exhaust accelerator, required when used with 045, 070 and 090 input models. 1-1/2 in pipe must transitioned to 2 in pipe when used with the flush mount kit

⁴Termination kits 30G28, 44W92, 44W93 and 81J20 are certified to ULC S636 for use in Canada only.

⁵See table 17 for vent accelerator requirements.

⁶2 in. To 1-1/2 in. Reducer required, must be field provided.

Joint Cementing Procedure

All cementing of joints should be done according to the specifications outlined in ASTM D 2855.

⚠ DANGER

DANGER OF EXPLOSION!

Fumes from PVC glue may ignite during system check. Allow fumes to dissipate for at least 5 minutes before placing unit into operation.

- 1 - Measure and cut vent pipe to desired length.
- 2 - Debur and chamfer end of pipe, removing any ridges or rough edges. If end is not chamfered, edge of pipe may remove cement from fitting socket and result in a leaking joint.
NOTE - Check the inside of vent pipe thoroughly for any obstruction that may alter furnace operation.
- 3 - Clean and dry surfaces to be joined.
- 4 - Test fit joint and mark depth of fitting on outside of pipe.
- 5 - Uniformly apply a liberal coat of PVC primer for PVC or use a clean dry cloth for ABS to clean inside socket surface of fitting and male end of pipe to depth of fitting socket.

NOTE - Time is critical at this stage. Do not allow primer to dry before applying cement.

- 6 - Promptly apply solvent cement to end of pipe and inside socket surface of fitting. Cement should be applied lightly but uniformly to inside of socket. Take care to keep excess cement out of socket. Apply second coat to end of pipe.
- 7 - Immediately after applying last coat of cement to pipe, and while both inside socket surface and end of pipe are wet with cement, forcefully insert end of pipe into socket until it bottoms out. Turn PVC pipe 1/4 turn during assembly (but not after pipe is fully inserted) to distribute cement evenly. DO NOT turn ABS or cellular core pipe.
NOTE - Assembly should be completed within 20 seconds after last application of cement. Hammer blows should not be used when inserting pipe.
- 8 - After assembly, wipe excess cement from pipe at end of fitting socket. A properly made joint will show a bead around its entire perimeter. Any gaps may indicate an improper assembly due to insufficient solvent.
- 9 - Handle joints carefully until completely set.

Venting Practices

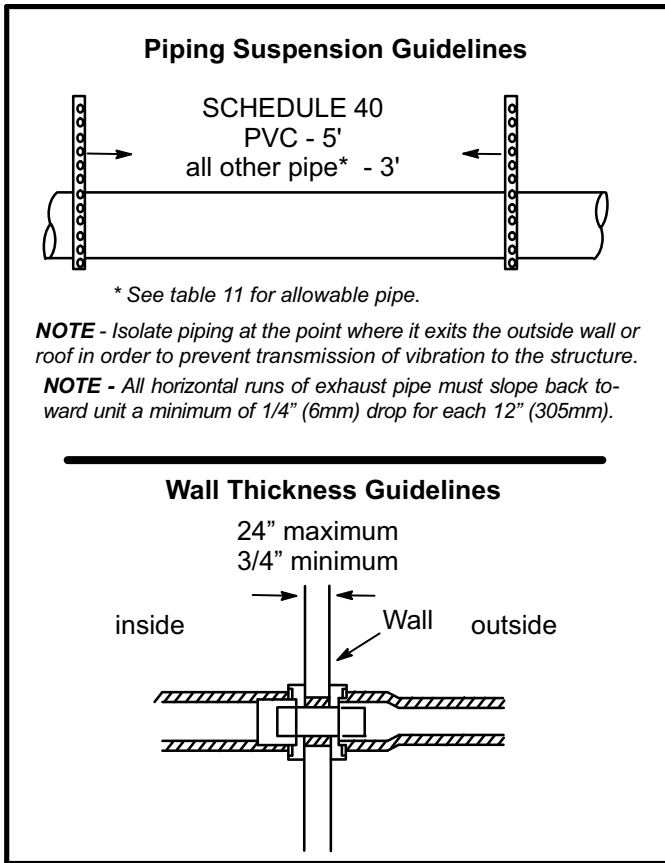

FIGURE 16

9. In areas where piping penetrates joists or interior walls, hole must be large enough to allow clearance on all sides of pipe through center of hole using a hanger.
10. When furnace is installed in a residence where unit is shut down for an extended period of time, such as a vacation home, make provisions for draining condensate collection trap and lines.

Removal of the Furnace from Common Vent

In the event that an existing furnace is removed from a venting system commonly run with separate gas appliances, the venting system is likely to be too large to properly vent the remaining attached appliances.

Conduct the following test while each appliance is operating and the other appliances (which are not operating) remain connected to the common venting system. If the venting system has been installed improperly, you **must** correct the system as indicated in the general venting requirements section.

⚠ WARNING

CARBON MONOXIDE POISONING HAZARD

Failure to follow the steps outlined below for each appliance connected to the venting system being placed into operation could result in carbon monoxide poisoning or death.

The following steps shall be followed for each appliance connected to the venting system being placed into operation, while all other appliances connected to the venting system are not in operation:

- 1 - Seal any unused openings in the common venting system.
- 2 - Inspect the venting system for proper size and horizontal pitch. Determine that there is no blockage, restriction, leakage, corrosion, or other deficiencies which could cause an unsafe condition.
- 3 - Close all building doors and windows and all doors between the space in which the appliances remaining connected to the common venting system are located and other spaces of the building. Turn on clothes dryers and any appliances not connected to the common venting system. Turn on any exhaust fans, such as range hoods and bathroom exhausts, so they will operate at maximum speed. Do not operate a summer exhaust fan. Close fireplace dampers.
- 4 - Follow the lighting instructions. Turn on the appliance that is being inspected. Adjust the thermostat so that the appliance operates continuously.
- 5 - After the main burner has operated for 5 minutes, test for leaks of flue gases at the draft hood relief opening. Use the flame of a match or candle.
- 6 - After determining that each appliance connected to the common venting system is venting properly, (step 3) return all doors, windows, exhaust fans, fireplace dampers, and any other gas-burning appliances to their previous mode of operation.

- 7 - If a venting problem is found during any of the preceding tests, the common venting system must be modified to correct the problem.

Resize the common venting system to the minimum vent pipe size determined by using the appropriate tables in Appendix G. (These are in the current standards of the National Fuel Gas Code ANSI Z223.1.

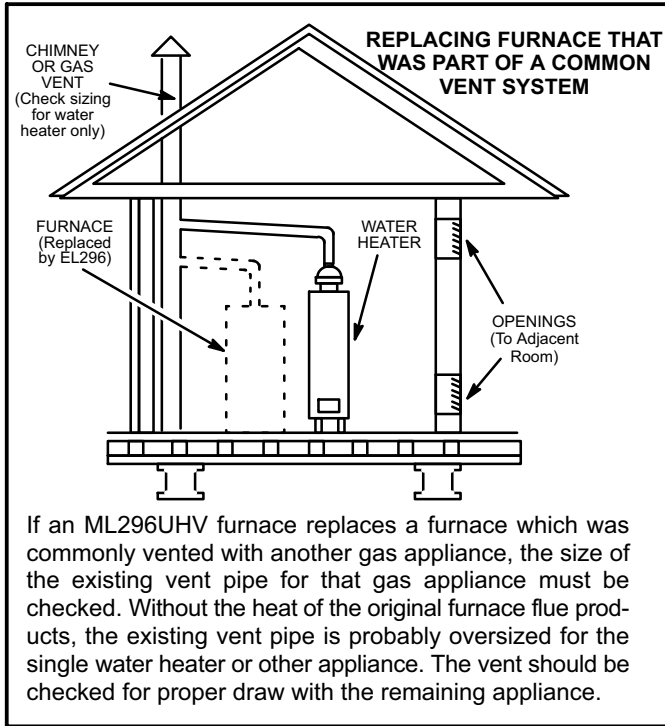

FIGURE 17

Exhaust Piping (Figures 18, 20 and 21)

Route piping to outside of structure. Continue with installation following instructions given in piping termination section.

⚠ CAUTION

Do not discharge exhaust into an existing stack or stack that also serves another gas appliance. If vertical discharge through an existing unused stack is required, insert PVC pipe inside the stack until the end is even with the top or outlet end of the metal stack.

⚠ CAUTION

The exhaust vent pipe operates under positive pressure and must be completely sealed to prevent leakage of combustion products into the living space.

Vent Piping Guidelines

NOTE - Lennox has approved the use of DuraVent® and Centrotherm manufactured vent pipe and terminations as an option to PVC. When using the PolyPro® by DuraVent or InnoFlue® by Centrotherm venting system the vent pipe re-

quirements stated in the unit installation instruction – minimum & maximum vent lengths, termination clearances, etc. – apply and must be followed. Follow the instructions provided with PolyPro by DuraVent and InnoFlue by Centrotherm venting system for assembly or if requirements are more restrictive. The PolyPro by DuraVent and InnoFlue by Centrotherm venting system must also follow the uninsulated and unconditioned space criteria listed in table 16.

The ML296UHV can be installed as either a Non-Direct Vent or a Direct Vent gas central furnace.

NOTE - In Non-Direct Vent installations, combustion air is taken from indoors or ventilated attic or crawlspace and flue gases are discharged outdoors. In Direct Vent installations, combustion air is taken from outdoors and flue gases are discharged outdoors.

Intake and exhaust pipe sizing -- Size pipe according to tables 13 and 14. Count all elbows inside and outside the home. Table 13 lists the *minimum* vent pipe lengths permitted. Table 14 lists the *maximum* pipe lengths permitted.

Regardless of the diameter of pipe used, the standard roof and wall terminations described in section *Exhaust Piping Terminations* should be used. Exhaust vent termination pipe is sized to optimize the velocity of the exhaust gas as it exits the termination. Refer to table 17.

In some applications which permit the use of several different sizes of vent pipe, a combination vent pipe may be used. Contact Lennox' Application Department for assistance in sizing vent pipe in these applications.

NOTE - The exhaust collar on all models is sized to accommodate 2" Schedule 40 vent pipe. In horizontal applications, any transition to exhaust pipe larger than 2" must be made in vertical runs of the pipe. Therefore a 2" elbow must be added before the pipe is transitioned to any size larger than 2". This elbow must be added to the elbow count used to determine acceptable vent lengths. Contact the Application Department for more information concerning sizing of vent systems which include multiple pipe sizes.

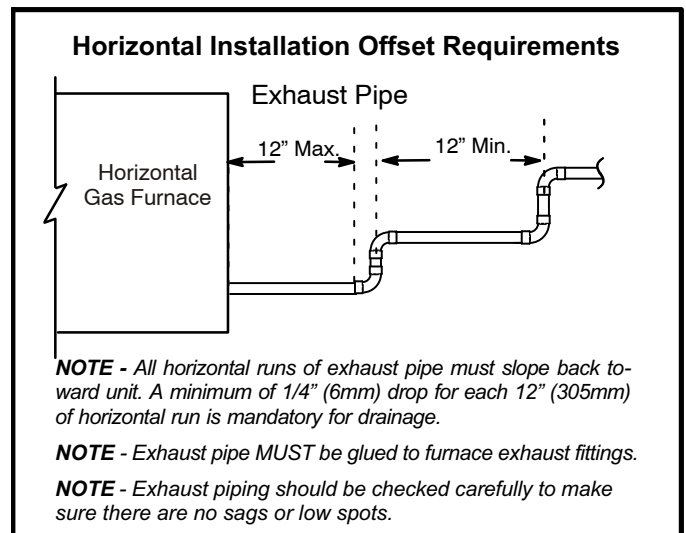

FIGURE 18

**TABLE 13
MINIMUM VENT PIPE LENGTHS**

ML296UHV MODEL	MIN. VENT LENGTH*
045, 070, 090, 110	15 ft. or 5 ft. plus 2 elbows or 10 ft. plus 1 elbow

*Any approved termination may be added to the minimum length listed.

Use the following steps to correctly size vent pipe diameter.

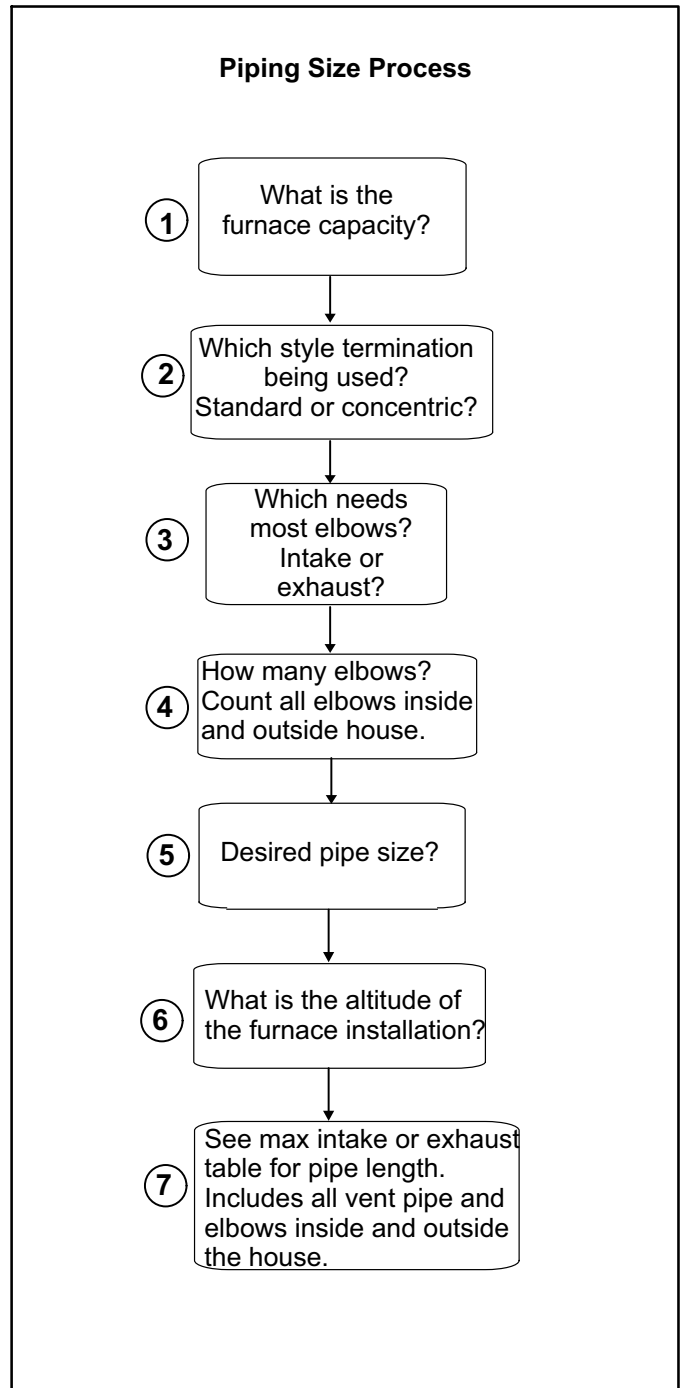

FIGURE 19

⚠ IMPORTANT

Do not use screens or perforated metal in exhaust or intake terminations. Doing so will cause freeze-ups and may block the terminations.

TABLE 14
Maximum Allowable Intake or Exhaust Vent Length in Feet

NOTE - Size intake and exhaust pipe length separately. Values in table are for Intake OR Exhaust, not combined total. Both Intake and Exhaust must be same pipe size.

NOTE - Additional vent pipe and elbows used to terminate the vent pipe outside the structure must be included in the total vent length calculation.

Standard Termination at Elevation 0 - 4500 ft																					
Number Of 90° Elbows Used	1-1/2" Pipe				2" Pipe				2-1/2" Pipe				3" Pipe								
	Model				Model				Model				Model								
	045	070	090	110	045	070	090	110	045	070	090	110	045	070	090	110					
1	25	20	n/a	n/a	81	66	44	24	115	115	93	58	138	137	118	118					
2	20	15			76	61	39	19	110	110	88	53	133	132	113	113	113				
3	15	10			71	56	34	14	105	105	83	48	128	127	108	108	108				
4	10	n/a			n/a	66	51	29	n/a	100	100	78	43	123	122	103	103				
5	n/a					n/a	61	46		24	95	95	73	38	118	117	98	98			
6							56	41		19	90	90	68	33	113	112	93	93			
7							51	36		14	85	85	63	28	108	107	88	88			
8							46	31		n/a	80	80	58	23	103	102	83	83			
9							41	26			75	75	53	18	98	97	78	78			
10							36	21			70	70	48	13	93	92	73	73			
Standard Termination Elevation 4500 - 10,000 ft																					
Number Of 90° Elbows Used			1-1/2" Pipe				2" Pipe				2-1/2" Pipe				3" Pipe						
		Model					Model				Model				Model						
	045	070	090	110	045	070	090	110	045	070	090	110	045	070	090	110					
1	25	20	n/a	n/a	81	66	44	n/a	115	115	93	58	138	137	118	118					
2	20	15			76	61	39		110	110	88	53	133	132	113	113					
3	15	10			71	56	34		105	105	83	48	128	127	108	108					
4	10	n/a			n/a	66	51		29	100	100	78	43	123	122	103	103				
5	n/a					n/a	61		46	24	95	95	73	38	118	117	98	98			
6							56		41	19	90	90	68	33	113	112	93	93			
7							51		36	14	85	85	63	28	108	107	88	88			
8							46		31	n/a	80	80	58	23	103	102	83	83			
9							41		26		75	75	53	18	98	97	78	78			
10							36		21		70	70	48	13	93	92	73	73			

See concentric terminations next page.

TABLE 14 Continued
Maximum Allowable Intake or Exhaust Vent Length in Feet

Size intake and exhaust pipe length separately. Values in table are for Intake OR Exhaust, not combined total. Both Intake and Exhaust must be same pipe size.

Concentric Termination at Elevation 0 - 4500 ft																	
Number Of 90° Elbows Used	1-1/2" Pipe				2" Pipe				2-1/2" Pipe				3" Pipe				
	Model				Model				Model				Model				
	045	070	090	110	045	070	090	110	045	070	090	110	045	070	090	110	
1	20	15	n/a	n/a	73	58	42	22	105	105	89	54	121	121	114	114	
2	15	10			68	53	37	17	100	100	84	49	116	116	109	109	109
3	10	n/a			63	48	32	12	95	95	79	44	111	111	104	104	104
4	n/a				58	43	27	n/a	90	90	74	39	106	106	99	99	99
5					53	38	22		85	85	69	34	101	101	94	94	
6					48	33	17		80	80	64	29	96	96	89	89	
7					43	28	12		75	75	59	24	91	91	84	84	
8					38	23	n/a		70	70	54	19	86	86	79	79	
9					33	18			65	65	49	14	81	81	74	74	
10					28	13			60	60	44	n/a	76	76	69	69	
Concentric Termination Elevation 4501 - 10,000 ft																	
Number Of 90° Elbows Used	1-1/2" Pipe				2" Pipe				2-1/2" Pipe				3" Pipe				
	Model				Model				Model				Model				
	045	070	090	110	045	070	090	110	045	070	090	110	045	070	090	110	
1	20	15	n/a	n/a	73	58	42	n/a	105	105	89	54	121	121	114	114	
2	15	10			68	53	37		100	100	84	49	116	116	109	109	
3	10	n/a			63	48	32		95	95	79	44	111	111	104	104	
4	n/a				58	43	27		90	90	74	39	106	106	99	99	
5					53	38	22		85	85	69	34	101	101	94	94	
6					48	33	17		80	80	64	29	96	96	89	89	
7					43	28	12		75	75	59	24	91	91	84	84	
8					38	23	n/a		70	70	54	19	86	86	79	79	
9					33	18			65	65	49	14	81	81	74	74	
10					28	13			60	60	44	n/a	76	76	69	69	

TABLE 15

Maximum Allowable Exhaust Vent Lengths With Furnace Installed in a Closet or Basement Using Ventilated Attic or Crawl Space For Intake Air in Feet

NOTE - Size intake and exhaust pipe length separately. Values in table are for Intake OR Exhaust, not combined total. Both Intake and Exhaust must be same pipe size.

NOTE - Additional vent pipe and elbows used to terminate the vent pipe outside the structure must be included in the total vent length calculation.

Standard Termination at Elevation 0 - 4500 ft																				
Number Of 90° Elbows Used	1-1/2" Pipe					2" Pipe					2-1/2" Pipe					3" Pipe				
	Model					Model					Model					Model				
	045	070	090	110	135	045	070	090	110	135	045	070	090	110	135	045	070	090	110	135
1	20	15	n/a	n/a	n/a	71	56	34	14	n/a	100	100	78	43	n/a	118	117	98	98	94
2	15	10				66	51	29	9		95	95	73	38		113	112	93	93	89
3	10	61				46	24	4	90		90	68	33	108		107	88	88	84	
4	n/a	n/a				56	41	19	85		85	63	28	103		102	83	83	79	
5						51	36	14	80		80	58	23	98		97	78	78	74	
6						46	31	9	85		75	63	18	93		92	73	73	69	
7						41	26	4	70		70	48	13	88		87	68	68	64	
8						36	21	n/a	65		65	43	8	83		82	63	63	59	
9						31	16		60		60	38	3	78		77	58	58	54	
10	26	11				55	55	33	n/a		73	72	53	53		49				
Standard Termination Elevation 4500 - 10,000 ft																				
Number Of 90° Elbows Used	1-1/2" Pipe					2" Pipe					2-1/2" Pipe					3" Pipe				
	Model					Model					Model					Model				
	045	070	090	110	135	045	070	090	110	135	045	070	090	110	135	045	070	090	110	135
1	20	15	n/a	n/a	n/a	71	56	34	n/a	n/a	100	100	78	43	n/a	118	117	98	98	94
2	15	10				66	51	29			95	95	73	38		113	112	93	93	89
3	10	61				46	24	90			90	68	33	108		107	88	88	84	
4	n/a	n/a				56	41	19			85	85	63	28		103	102	83	83	79
5						51	36	14			80	80	58	23		98	97	78	78	74
6						46	31	9			85	85	53	18		93	92	73	73	69
7						41	26	4			70	70	48	13		88	87	68	68	64
8						36	21	n/a			65	65	43	8		83	82	63	63	59
9						31	16				60	60	38	3		78	77	58	58	54
10	26	11				55	55	33			n/a	73	72	53		53	49			

Intake Piping

The ML296UHV furnace may be installed in either **direct vent** or **non-direct vent** applications. In non-direct vent applications, when intake air will be drawn into the furnace from the surrounding space, the indoor air quality must be considered and guidelines listed in Combustion, Dilution and Ventilation Air section must be followed.

Follow the next two steps when installing the unit in **Direct Vent applications**, where combustion air is taken from outdoors and flue gases are discharged outdoors. **The provided air intake screen must not be used in direct vent applications (outdoors).**

- 1 - Use transition solvent cement or a sheet metal screw to secure the intake pipe to the inlet air connector.
- 2 - Route piping to outside of structure. Continue with installation following instructions given in general guidelines for piping terminations and intake and exhaust piping terminations for direct vent sections. Refer to table 14 for pipe sizes.

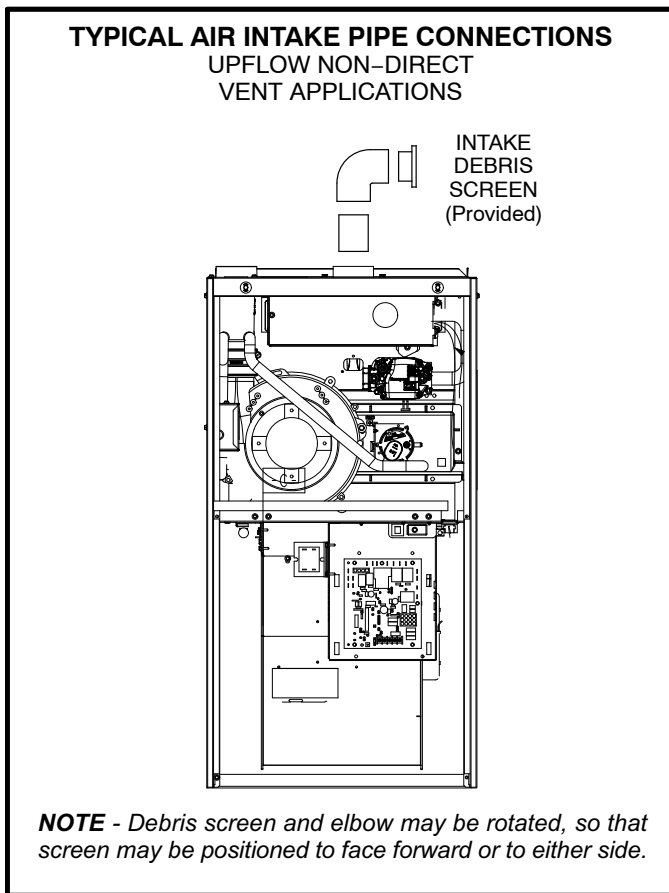

FIGURE 22

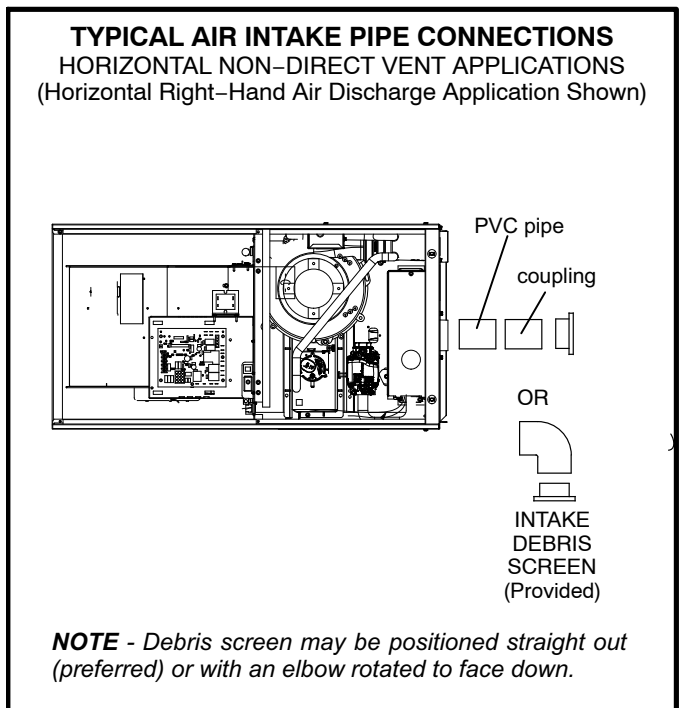

FIGURE 23

Follow the next two steps when installing the unit in **Non-Direct Vent applications** where combustion air is taken from indoors or ventilated attic or crawlspace and flue gases are discharged outdoors.

- 1 - Use field-provided materials and the factory-provided air intake screen to route the intake piping as shown in figure 22 or 23. Maintain a minimum clearance of 3" (76mm) around the air intake opening. The air intake opening (with the protective screen) should always be directed forward or to either side in the upflow position, and either straight out or downward in the horizontal position.

The air intake piping must not terminate too close to the flooring or a platform. Ensure that the intake air inlet will not be obstructed by loose insulation or other items that may clog the debris screen.

- 2 - If intake air is drawn from a ventilated attic (figure 24) or ventilated crawlspace (figure 25) the exhaust vent length must not exceed those listed in table 15. If 3" diameter pipe is used, reduce to 2" diameter pipe at the termination point to accommodate the debris screen.
- 3 - Use a sheet metal screw to secure the intake pipe to the connector, if desired.

⚠ CAUTION

If this unit is being installed in an application with combustion air coming in from a space serviced by an exhaust fan, power exhaust fan, or other device which may create a negative pressure in the space, take care when sizing the inlet air opening. The inlet air opening must be sized to accommodate the maximum volume of exhausted air as well as the maximum volume of combustion air required for all gas appliances serviced by this space.

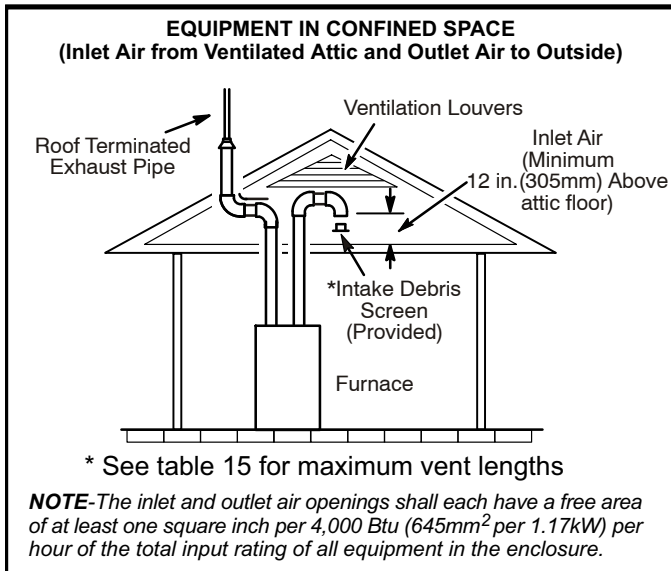

FIGURE 24

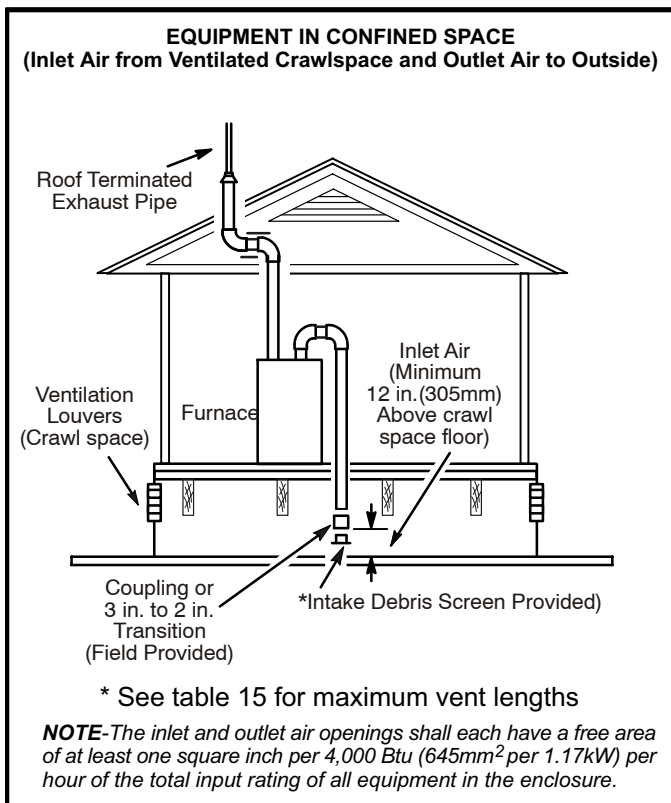

FIGURE 25

General Guidelines for Vent Terminations

In Non-Direct Vent applications, combustion air is taken from indoors or ventilated attic or crawlspace and the flue gases are discharged to the outdoors. The ML296UHV is then classified as a non-direct vent, Category IV gas furnace.

In Direct Vent applications, combustion air is taken from outdoors and the flue gases are discharged to the outdoors. The ML296UHV is then classified as a direct vent, Category IV gas furnace.

In both Non-Direct Vent and Direct Vent applications, the vent termination is limited by local building codes. In the absence of local codes, refer to the current National Fuel Gas Code ANSI Z223-1/NFPA 54 in U.S.A., and current CSA-B149 Natural Gas and Propane Installation Codes in Canada for details.

Position termination according to location given in figure 27 or 28. In addition, position termination so it is free from any obstructions and 12" above the average snow accumulation.

At vent termination, care must be taken to maintain protective coatings over building materials (prolonged exposure to exhaust condensate can destroy protective coatings). It is recommended that the exhaust outlet not be located within 6 feet (1.8m) of an outdoor AC unit because the condensate can damage the painted coating.

NOTE - See table 16 for maximum allowed exhaust pipe length without insulation in unconditioned space during winter design temperatures below 32°F (0°C). If required exhaust pipe should be insulated with 1/2" (13mm) Armaflex or equivalent. In extreme cold climate areas, 3/4" (19mm) Armaflex or equivalent may be necessary. Insulation must be protected from deterioration. Armaflex with UV protection is permissible. Basements or other enclosed areas that are not exposed to the outdoor ambient temperature and are above 32 degrees F (0°C) are to be considered conditioned spaces.

⚠ IMPORTANT

Do not use screens or perforated metal in exhaust terminations. Doing so will cause freeze-ups and may block the terminations.

⚠ IMPORTANT

For Canadian Installations Only:
In accordance to CSA International B149 installation codes, the minimum allowed distance between the combustion air intake inlet and the exhaust outlet of other appliances shall not be less than 12 inches (305mm).

TABLE 16
Maximum Allowable Exhaust Vent Pipe Length (in ft.³) Without Insulation In Unconditioned Space For
Winter Design Temperatures Two - Stage High Efficiency Furnace

Winter Design Temperatures ¹ °F (°C)	Vent Pipe Diameter	Unit Input Size							
		045		070		090		110	
		PVC	² PP	PVC	² PP	PVC	² PP	PVC	² PP
32 to 21 (0 to -6)	1-1/2 in.	22	N/A	25	N/A	N/A	N/A	N/A	N/A
	2 in.	21	18	33	30	46	42	30	30
	2-1/2 in.	16	N/A	26	N/A	37	N/A	36	N/A
	3 in.	12	12	21	21	30	30	29	29
20 to 1 (-7 to -17)	1-1/2 in.	12	N/A	20	N/A	N/A	N/A	N/A	N/A
	2 in.	11	9	19	17	28	25	27	24
	2-1/2 in.	7	N/A	14	N/A	21	N/A	20	N/A
	3 in.	N/A	N/A	9	9	16	16	14	14
0 to -20 (-18 to -29)	1-1/2 in.	8	N/A	13	N/A	N/A	N/A	N/A	N/A
	2 in.	6	4	12	10	19	16	18	15
	2-1/2 in.	N/A	N/A	7	N/A	13	N/A	12	N/A
	3 in.	N/A	N/A	N/A	N/A	8	8	7	7

¹Refer to 99% Minimum Design Temperature table provided in the current edition of the ASHRAE Fundamentals Handbook.

²Poly-Propylene vent pipe (PP) by Duravent and Centrotherm.

³Vent length are equivalent length. Consider each elbow as 5ft of linear length.

NOTE - Concentric terminations are the equivalent of 5' and should be considered when measuring pipe length.

NOTE - Maximum uninsulated vent lengths listed may include the termination (vent pipe exterior to the structure) and cannot exceed 5 linear feet or the maximum allowable intake or exhaust vent length listed in table 14 or 15 which ever is less.

NOTE - If insulation is required in an unconditioned space, it must be located on the pipe closest to the furnace. See figure 26.

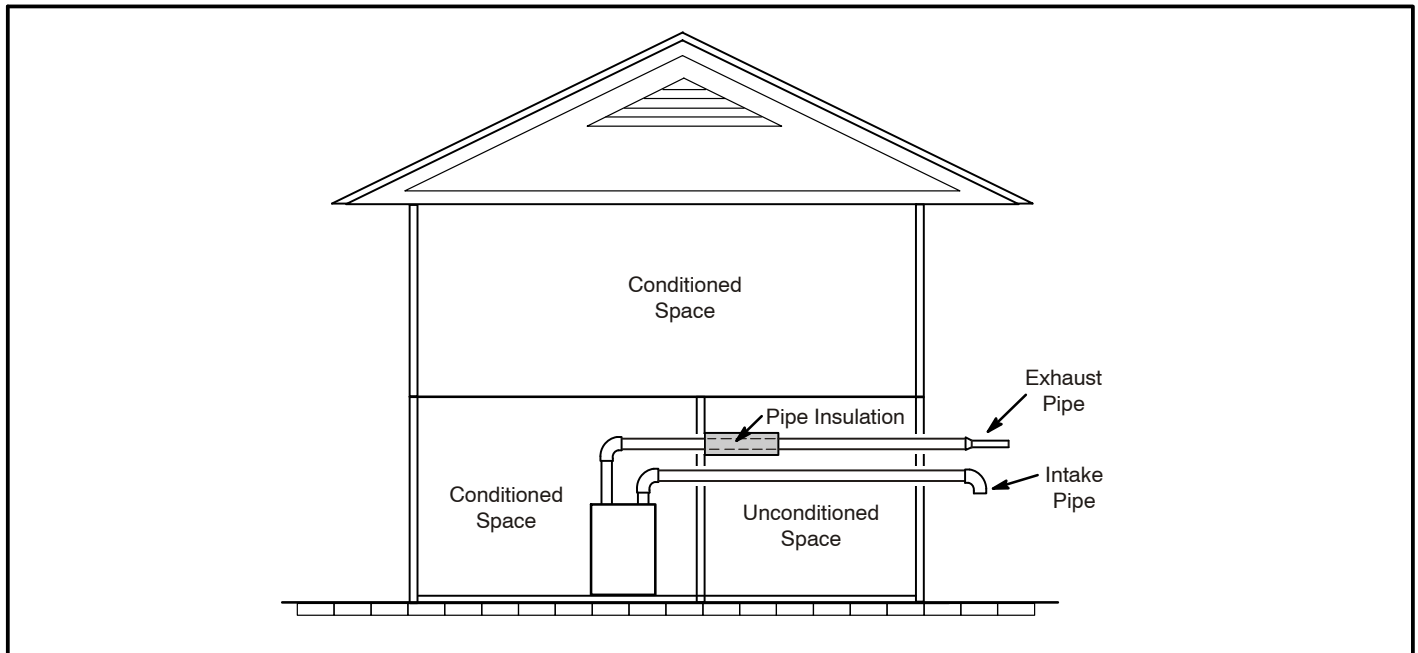
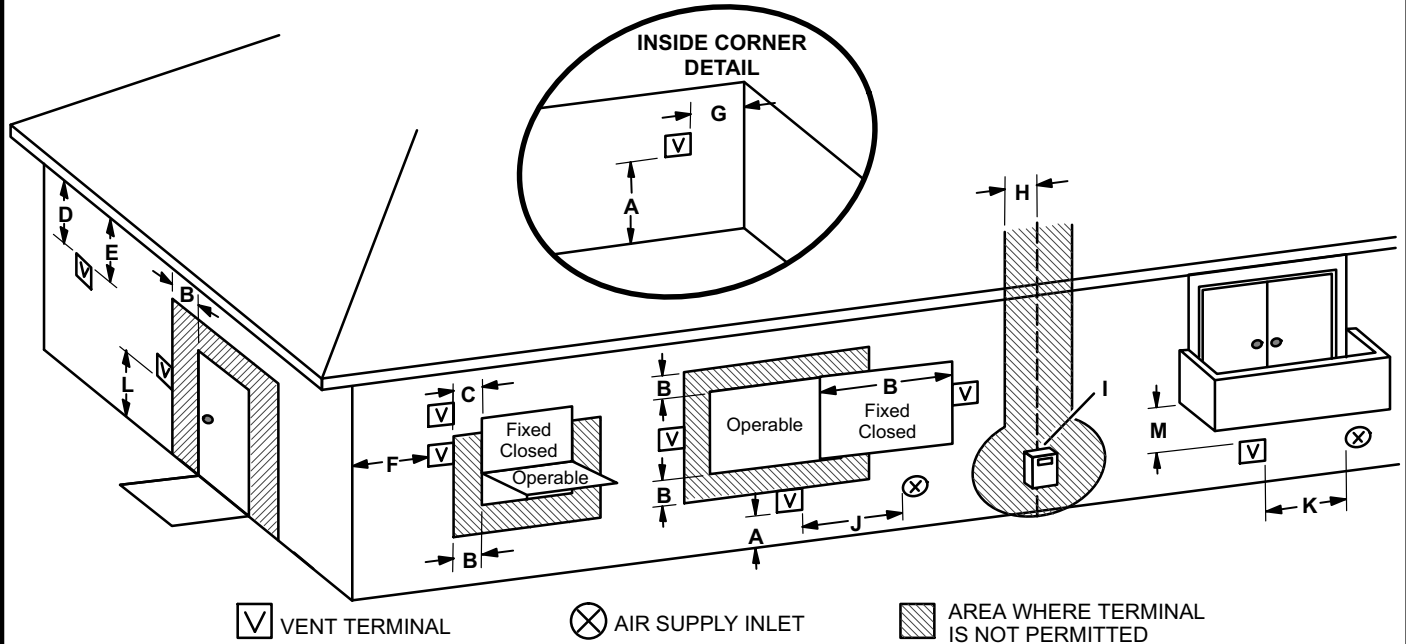

FIGURE 26

VENT TERMINATION CLEARANCES FOR NON-DIRECT VENT INSTALLATIONS IN THE US AND CANADA



	US Installations ¹	Canadian Installations ²	
A =	Clearance above grade, veranda, porch, deck or balcony	12 inches (305mm) or 12 in. (305mm) above average snow accumulation.	12 inches (305mm) or 12 in. (305mm) above average snow accumulation.
B =	Clearance to window or door that may be opened	4 feet (1.2 m) below or to side of opening; 1 foot (30cm) above opening	6 inches (152mm) for appliances <10,000 Btuh (3kw), 12 inches (305mm) for appliances > 10,000 Btuh (3kw) and <100,000 Btuh (30kw), 36 inches (.9m) for appliances > 100,000 Btuh (30kw)
C =	Clearance to permanently closed window	* 12"	* 12"
D =	Vertical clearance to ventilated soffit located above the terminal within a horizontal distance of 2 feet (610 mm) from the center line of the terminal	* Equal to or greater than soffit depth.	* Equal to or greater than soffit depth.
E =	Clearance to unventilated soffit	* Equal to or greater than soffit depth.	* Equal to or greater than soffit depth.
F =	Clearance to outside corner	* No minimum to outside corner	* No minimum to outside corner
G =	Clearance to inside corner	*	*
H =	Clearance to each side of center line extended above meter / regulator assembly	* 3 feet (.9m) within a height 15 feet (4.5m) above the meter / regulator assembly	3 feet (.9m) within a height 15 feet (4.5m) above the meter / regulator assembly
I =	Clearance to service regulator vent outlet	* 3 feet (.9m)	3 feet (.9m)
J =	Clearance to non-mechanical air supply inlet to building or the combustion air inlet to any other appliance	4 feet (1.2 m) below or to side of opening; 1 foot (30 cm) above opening	6 inches (152mm) for appliances <10,000 Btuh (3kw), 12 inches (305mm) for appliances > 10,000 Btuh (3kw) and <100,000 Btuh (30kw), 36 inches (.9m) for appliances > 100,000 Btuh (30kw)
K =	Clearance to mechanical air supply inlet	3 feet (.9m) above if within 10 feet (3m) horizontally	6 feet (1.8m)
L =	Clearance above paved sidewalk or paved driveway located on public property	7 feet (2.1m)†	7 feet (2.1m)†
M =	Clearance under veranda, porch, deck or balcony	*12 inches (305mm)‡	12 inches (305mm)‡

¹ In accordance with the current ANSI Z223.1/NFPA 54 Natural Fuel Gas Code

² In accordance with the current CSA B149.1, Natural Gas and Propane Installation Code

† A vent shall not terminate directly above a sidewalk or paved driveway that is located between two single family dwellings and serves both dwellings.

‡ Permitted only if veranda, porch, deck or balcony is fully open on a minimum of two sides beneath the floor. Lennox recommends avoiding this location if possible.

*For clearances not specified in ANSI Z223.1/NFPA 54 or CSA B149.1, clearance will be in accordance with local installation codes and the requirements of the gas supplier and these installation instructions."

FIGURE 27

VENT TERMINATION CLEARANCES FOR DIRECT VENT INSTALLATIONS IN THE US AND CANADA

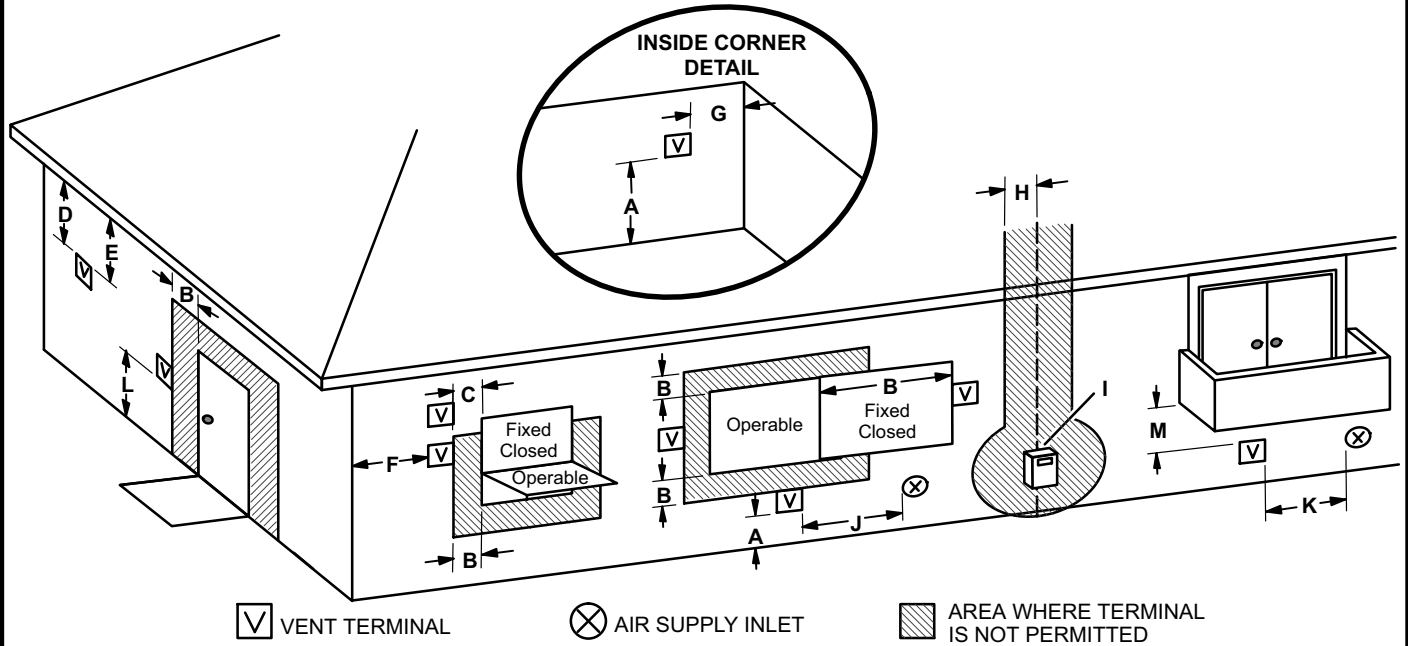

	US Installations ¹	Canadian Installations ²	
A =	Clearance above grade, veranda, porch, deck or balcony	12 inches (305mm) or 12 in. (305mm) above average snow accumulation.	12 inches (305mm) or 12 in. (305mm) above average snow accumulation.
B =	Clearance to window or door that may be opened	6 inches (152mm) for appliances <10,000 Btuh (3kw), 9 inches (228mm) for appliances > 10,000 Btuh (3kw) and <50,000 Btuh (15 kw), 12 inches (305mm) for appliances > 50,000 Btuh (15kw)	6 inches (152mm) for appliances <10,000 Btuh (3kw), 12 inches (305mm) for appliances > 10,000 Btuh (3kw) and <100,000 Btuh (30kw), 36 inches (.9m) for appliances > 100,000 Btuh (30kw)
C =	Clearance to permanently closed window	* 12"	* 12"
D =	Vertical clearance to ventilated soffit located above the terminal within a horizontal distance of 2 feet (610mm) from the center line of the terminal	* Equal to or greater than soffit depth	* Equal to or greater than soffit depth
E =	Clearance to unventilated soffit	* Equal to or greater than soffit depth	* Equal to or greater than soffit depth
F =	Clearance to outside corner	* No minimum to outside corner	* No minimum to outside corner
G =	Clearance to inside corner	*	*
H =	Clearance to each side of center line extended above meter / regulator assembly	3 feet (.9m) within a height 15 feet (4.5m) above the meter / regulator assembly	3 feet (.9m) within a height 15 feet (4.5m) above the meter / regulator assembly
I =	Clearance to service regulator vent outlet	* 3 feet (.9m)	3 feet (.9m)
J =	Clearance to non-mechanical air supply inlet to building or the combustion air inlet to any other appliance	6 inches (152mm) for appliances <10,000 Btuh (3kw), 9 inches (228mm) for appliances > 10,000 Btuh (3kw) and <50,000 Btuh (15 kw), 12 inches (305mm) for appliances > 50,000 Btuh (15kw)	6 inches (152mm) for appliances <10,000 Btuh (3kw), 12 inches (305mm) for appliances > 10,000 Btuh (3kw) and <100,000 Btuh (30kw), 36 inches (.9m) for appliances > 100,000 Btuh (30kw)
K =	Clearance to mechanical air supply inlet	3 feet (.9m) above if within 10 feet (3m) horizontally	6 feet (1.8m)
L =	Clearance above paved sidewalk or paved driveway located on public property	* 7 feet (2.1m)	7 feet (2.1m)†
M =	Clearance under veranda, porch, deck or balcony	*12 inches (305mm)‡	12 inches (305mm)‡

¹ In accordance with the current ANSI Z223.1/NFPA 54 Natural Fuel Gas Code

² In accordance with the current CSA B149.1, Natural Gas and Propane Installation Code

† A vent shall not terminate directly above a sidewalk or paved driveway that is located between two single family dwellings and serves both dwellings.

‡ Permitted only if veranda, porch, deck or balcony is fully open on a minimum of two sides beneath the floor. Lennox recommends avoiding this location if possible.

*For clearances not specified in ANSI Z223.1/NFPA 54 or CSA B149.1, clearance will be in accordance with local installation codes and the requirements of the gas supplier and these installation instructions."

FIGURE 28

Details of Intake and Exhaust Piping Terminations for Direct Vent Installations

NOTE - In Direct Vent installations, combustion air is taken from outdoors and flue gases are discharged to outdoors.

NOTE - Flue gas may be slightly acidic and may adversely affect some building materials. If any vent termination is used and the flue gasses may impinge on the building material, a corrosion-resistant shield (minimum 24 inches square) should be used to protect the wall surface. If the optional tee is used, the protective shield is recommended. The shield should be constructed using wood, plastic, sheet metal or other suitable material. All seams, joints, cracks, etc. in the affected area should be sealed using an appropriate sealant. See figure 37.

Intake and exhaust pipes may be routed either horizontally through an outside wall or vertically through the roof. In attic or closet installations, vertical termination through the roof is preferred. Figures 29 through 36 show typical terminations.

1. Intake and exhaust terminations are not required to be in the same pressure zone. You may exit the intake on one side of the structure and the exhaust on another side (figure 30). You may exit the exhaust out the roof and the intake out the side of the structure (figure 31).
2. Intake and exhaust pipes should be placed as close together as possible at termination end (refer to illustrations). Maximum separation is 3" (76MM) on roof terminations and 6" (152MM) on side wall terminations.

NOTE - When venting in different pressure zones, the maximum separation requirement of intake and exhaust pipe DOES NOT apply.

3. On roof terminations, the intake piping should terminate straight down using two 90° elbows (See figure 29).
4. Exhaust piping must terminate straight out or up as shown. A reducer may be required on the exhaust piping at the point where it exits the structure to improve the velocity of exhaust away from the intake piping. See table 17.

NOTE - Care must be taken to avoid recirculation of exhaust back into intake pipe.

5. On field-supplied terminations for side wall exit, exhaust piping may extend a maximum of 12 inches (305MM) for 2" PVC and 20 inches (508MM) for 3" (76MM) PVC beyond the outside wall. Intake piping should be as short as possible. See figure 37.
6. On field-supplied terminations, a minimum distance between the end of the exhaust pipe and the end of the intake pipe without a termination elbow is 8" and a minimum distance of 6" with a termination elbow. See figure 37.

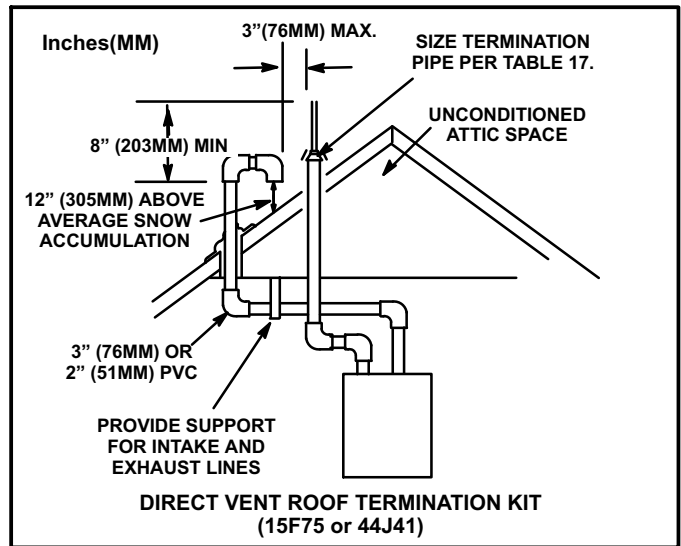

FIGURE 29

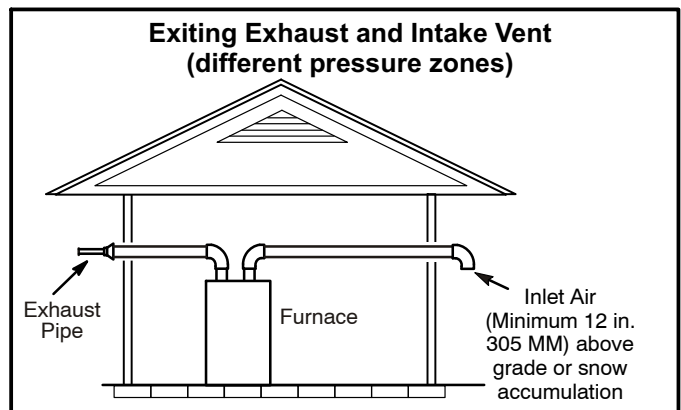

FIGURE 30

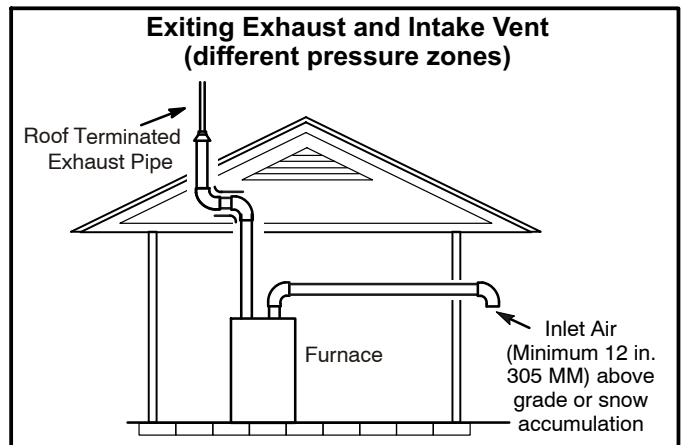

FIGURE 31

TABLE 17
EXHAUST PIPE TERMINATION SIZE REDUCTION

ML296UHV MODEL	Termination Pipe Size
*045 and 070	1-1/2" (38MM)
*090	2" (51MM)
110	2" (51MM)

7. If intake and exhaust piping must be run up a side wall to position above snow accumulation or other obstructions, piping must be supported. At least one bracket must be used within 6" from the top of the elbow and then every 24" (610mm) as shown in figure 37, to prevent any movement in any direction. When exhaust and intake piping must be run up an outside wall, the exhaust piping must be terminated with pipe sized per table 17. The intake piping may be equipped with a 90° elbow turndown. Using turndown will add 5 feet (1.5m) to the equivalent length of the pipe.

*ML296UHV-045, -070 and -090 units with the flush mount termination must use the 1-1/2" accelerator supplied with the kit.

8. A multiple furnace installation may use a group of up to four terminations assembled together horizontally, as shown in figure 35.
9. A multiple furnace installation may use a group of up to four terminations assembled together horizontally, as shown in figure 35.

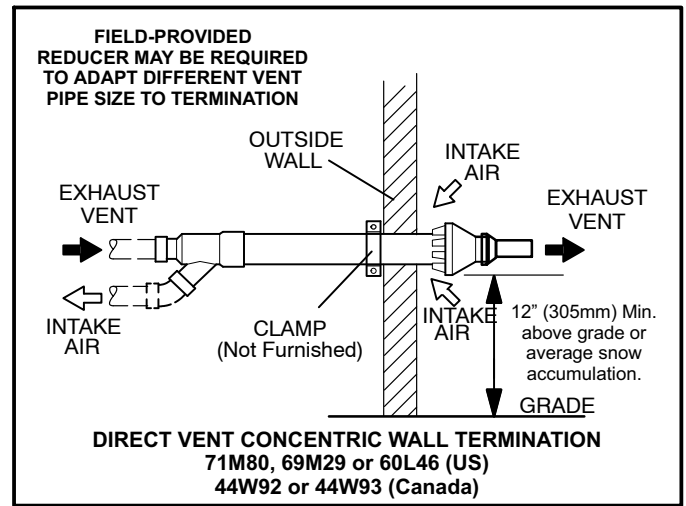

FIGURE 34

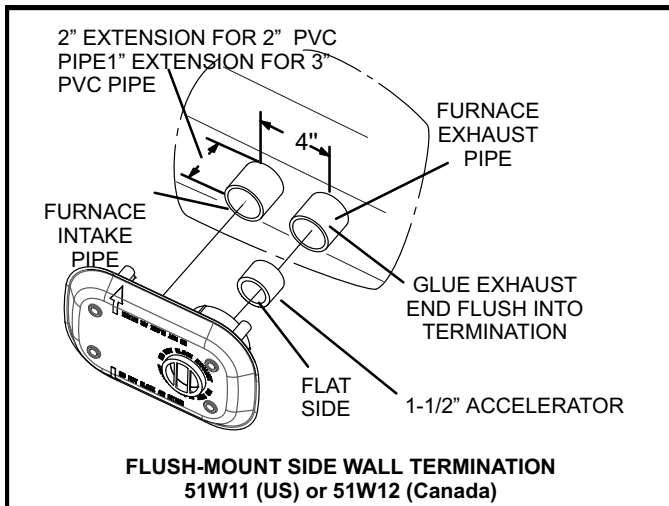

FIGURE 32

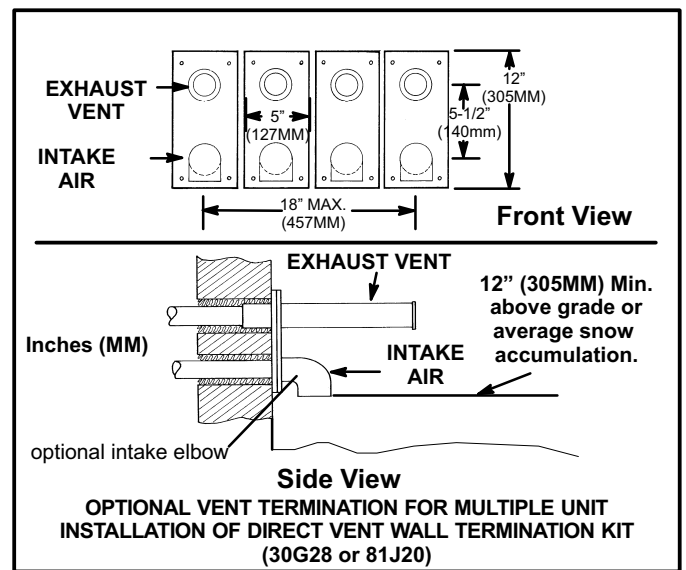

FIGURE 35

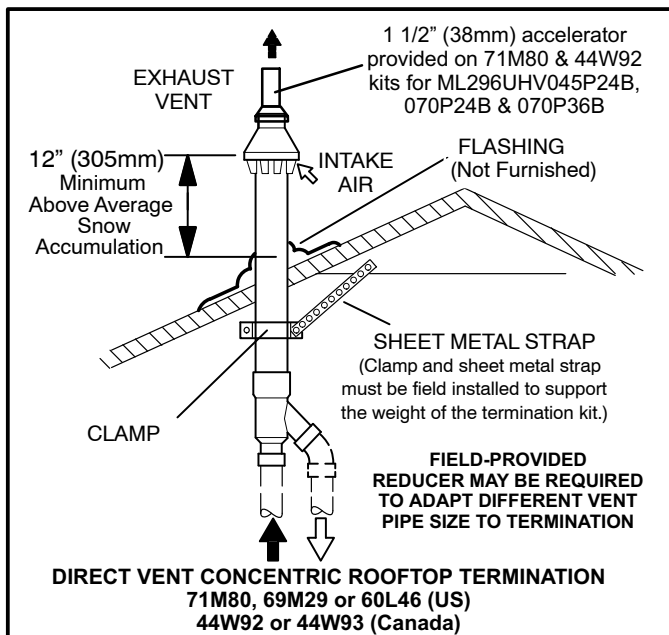

FIGURE 33

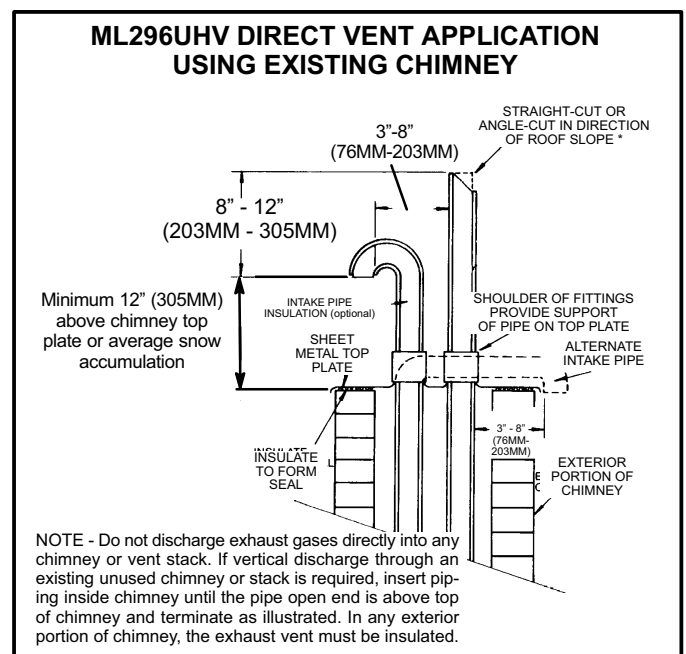
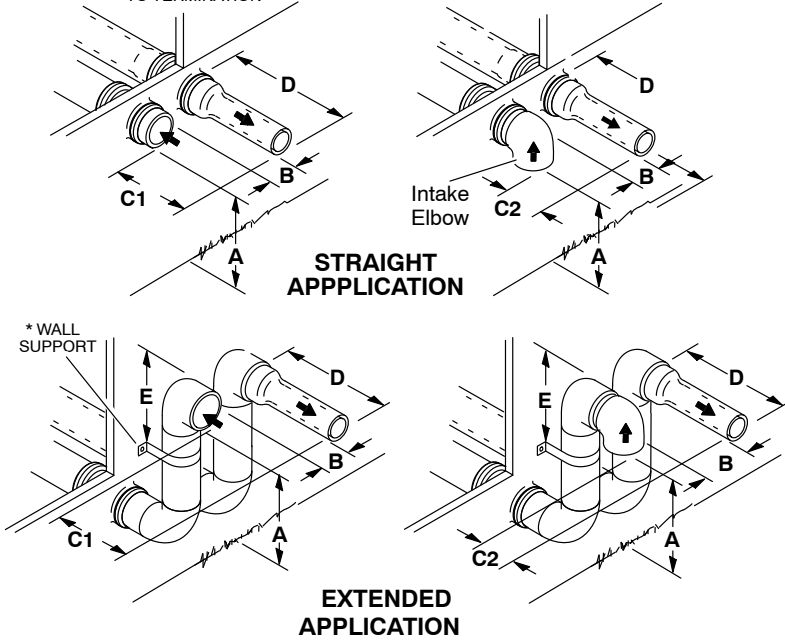

FIGURE 36

NOTE - FIELD-PROVIDED REDUCER MAY BE REQUIRED TO ADAPT LARGER VENT PIPE SIZE TO TERMINATION

FIELD FABRICATED WALL TERMINATION



	2" (51mm) Vent Pipe	3" (76mm) Vent Pipe
A - Minimum clearance above grade or average snow accumulation	12" (305 mm)	12" (305 mm)
B - Maximum horizontal separation between intake and exhaust	6" (152 mm)	6" (152 mm)
C1 -Minimum from end of exhaust to inlet of intake	8" (203 mm)	8" (203 mm)
C2 -Minimum from end of exhaust to inlet of intake	6" (152 mm)	6" (152 mm)
D - Maximum exhaust pipe length	12" (305 mm)	20" (508 mm)
E - Maximum wall support distance from top of each pipe (intake/exhaust)	6" (152 mm)	6" (152 mm)

See maximum allowable venting tables for venting lengths with this arrangement.

* Use wall support every 24" (610 mm). Use two wall supports if extension is greater than 24" (610 mm) but less than 48" (1219 mm).

NOTE - One wall support must be within 6" (152 mm) from top of each pipe (intake and exhaust) to prevent movement in any direction.

ALTERNATE TERMINATIONS (TEE & FORTY-FIVE DEGREE ELBOWS ONLY)

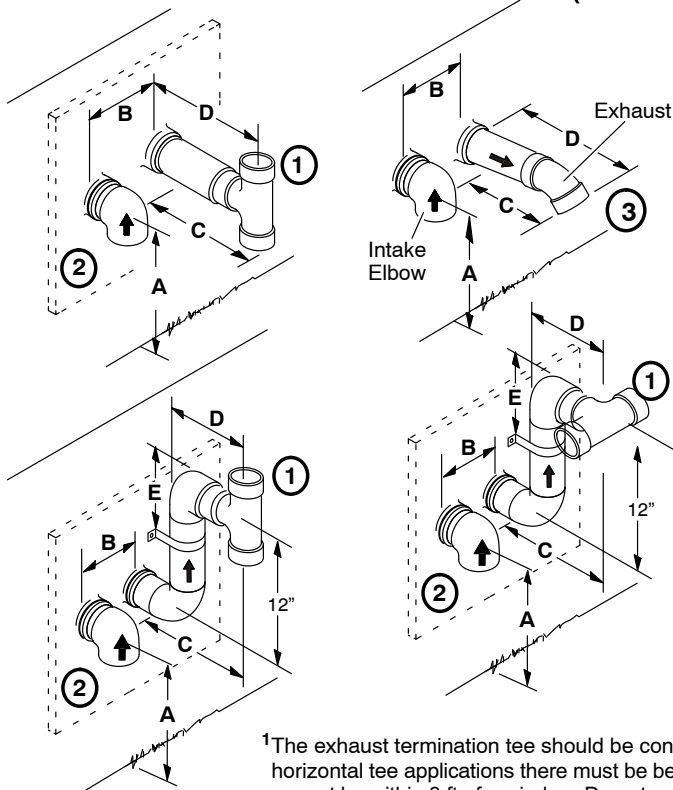

	2" (51MM) Vent Pipe	3" (76MM) Vent Pipe
A - Clearance above grade or average snow accumulation	12" (305 mm) Min.	12" (305 mm) Min.
B - Horizontal separation between intake and exhaust	6" (152 mm) Min. 24" (610 mm) Max.	6" (152 mm) Min. 24" (610 mm) Max.
C - Minimum from end of exhaust to inlet of intake	9" (227 mm) Min.	9" (227 mm) Min.
D - Exhaust pipe length	12" (305 mm) Min. 16" (405 mm) Max.	12" (305 mm) Min. 20" (508 mm) Max.
E - Wall support distance from top of each pipe (intake/exhaust)	6" (152 mm) Max.	6" (152 mm) Max.

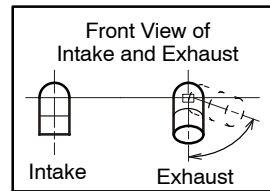

¹The exhaust termination tee should be connected to the 2" or 3" PVC flue pipe as shown in the illustration. In horizontal tee applications there must be a minimum of 3 ft away from covered patios or any living areas and cannot be within 3 ft of a window. Do not use an accelerator in applications that include an exhaust termination tee. The accelerator is not required.

² As required. Flue gas may be acidic and may adversely affect some building materials. If a side wall vent termination is used and flue gases will impinge on the building materials, a corrosion-resistant shield (24 inches square) should be used to protect the wall surface. If optional tee is used, the protective shield is recommended. The shield should be constructed using wood, sheet metal or other suitable material. All seams, joints, cracks, etc. in affected area, should be sealed using an appropriate sealant.

³ Exhaust pipe 45° elbow can be rotated to the side away from the combustion air inlet to direct exhaust away from adjacent property. The exhaust must never be directed toward the combustion air inlet.

FIGURE 37

Details of Exhaust Piping Terminations for Non-Direct Vent Applications

Exhaust pipes may be routed either horizontally through an outside wall or vertically through the roof. In attic or closet installations, vertical termination through the roof is preferred. Figures 38 and 39 show typical terminations.

1. Exhaust piping must terminate straight out or up as shown. The termination pipe must be sized as listed in table 17. The specified pipe size ensures proper velocity required to move the exhaust gases away from the building.
2. On field supplied terminations for side wall exit, exhaust piping may extend a maximum of 12 inches (305MM) for 2" PVC and 20 inches (508MM) for 3" (76MM) PVC beyond the outside wall.

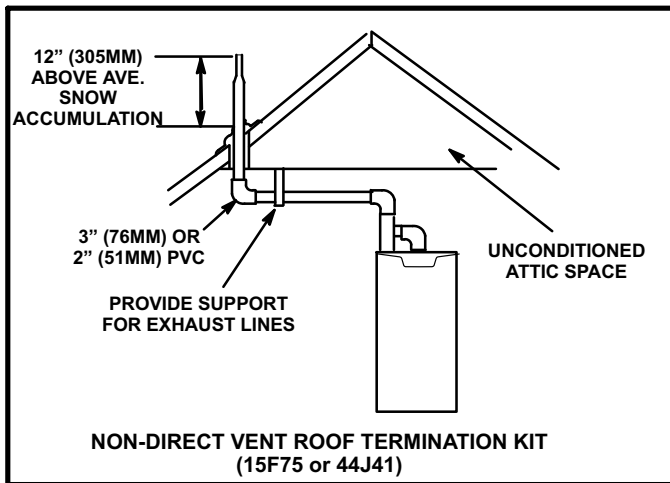

FIGURE 38

3. If exhaust piping must be run up a side wall to position above snow accumulation or other obstructions, piping must be supported every 24 inches (610MM). When exhaust piping must be run up an outside wall, any reduction in exhaust pipe size must be done after the final elbow.
4. Distance between exhaust pipe terminations on multiple furnaces must meet local codes.

Crawl Space and Extended Horizontal Venting

Lennox provides kit 51W18 to install 2" or 3" PVC exhaust piping through the floor joists and into the the crawl space. See figure 40.

This kit can also be used as a supplemental drain for installations with condensate run back in the vent pipe (ie. long horizontal runs, unconditioned spaces, etc.).

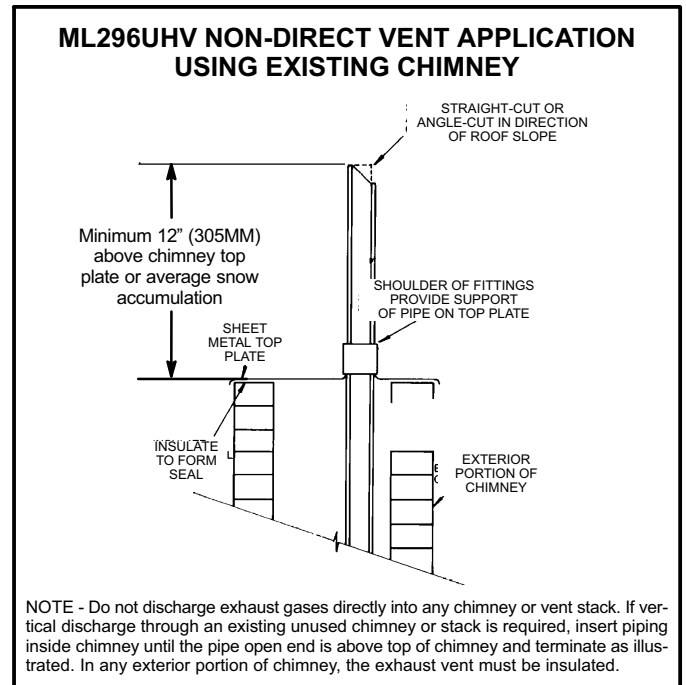

FIGURE 39

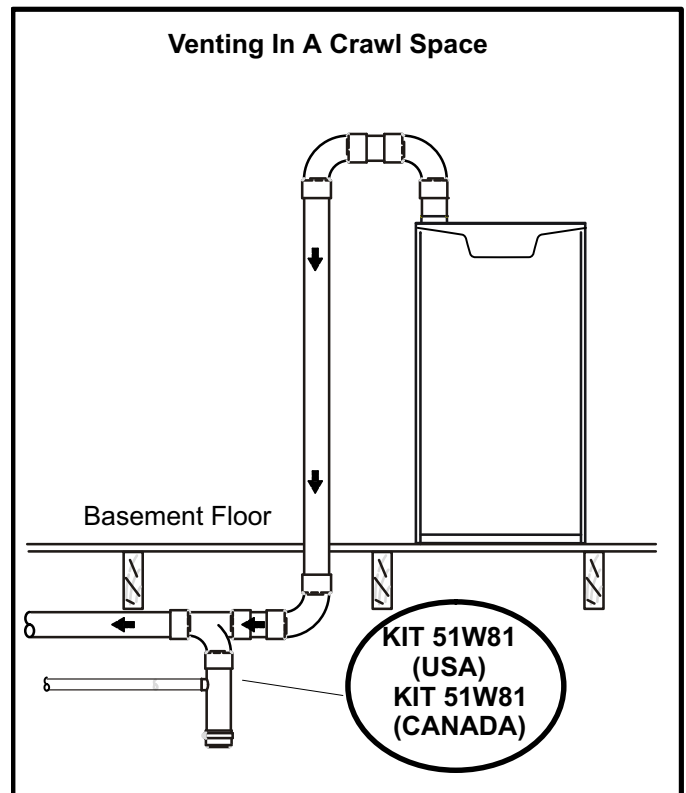

FIGURE 40

Condensate Piping

This unit is designed for either right- or left-side exit of condensate piping in upflow applications. In horizontal applications, the condensate trap must extend below the unit. An 8" service clearance is required for the condensate trap. Refer to figures 41 and 43 for condensate trap locations. Figure 49 shows trap assembly using 1/2" PVC or 3/4" PVC.

NOTE - If necessary the condensate trap may be installed up to 5' away from the furnace. Use PVC pipe to connect trap to furnace condensate outlet. Piping from furnace must slope down a minimum of 1/4" per ft. toward trap.

- 1 - Determine which side condensate piping will exit the unit, location of trap, field-provided fittings and length of PVC pipe required to reach available drain.
- 2 - Use a large flat head screw driver or a 1/2" drive socket extension and remove plug (figure 41) from the cold end header box at the appropriate location on the side of the unit. Install provided 3/4 NPT street elbow fitting into cold end header box. Use Teflon tape or appropriate pipe dope.

NOTE - Cold end header box drain plugs are factory installed. Check the unused plug for tightness to prevent leakage.

- 3 - Install the cap over the clean out opening at the base of the trap. Secure with clamp. See figure 49.
- 4 - Install drain trap using appropriate PVC fittings, glue all joints. Glue the provided drain trap as shown in figure 49. Route the condensate line to an open drain. Condensate line must maintain a 1/4" downward slope from the furnace to the drain.
- 5 - Figures 44 and 45 show the furnace and evaporator coil using a separate drain. If necessary the condensate line from the furnace and evaporator coil can drain together. See figures 46, 47 and 48.

Upflow furnace (figure 47) - In upflow furnace applications the field provided vent must be a minimum 1" to a maximum 2" length above the condensate drain outlet connection. Any length above 2" may result in a flooded heat exchanger if the combined primary drain line were to become restricted.

Horizontal furnace (figure 48) - In horizontal furnace applications the field provided vent must be a minimum 4" to a maximum 5" length above the condensate drain outlet connection. Any length above 5" may result in a flooded heat exchanger if the combined primary drain line were to become restricted.

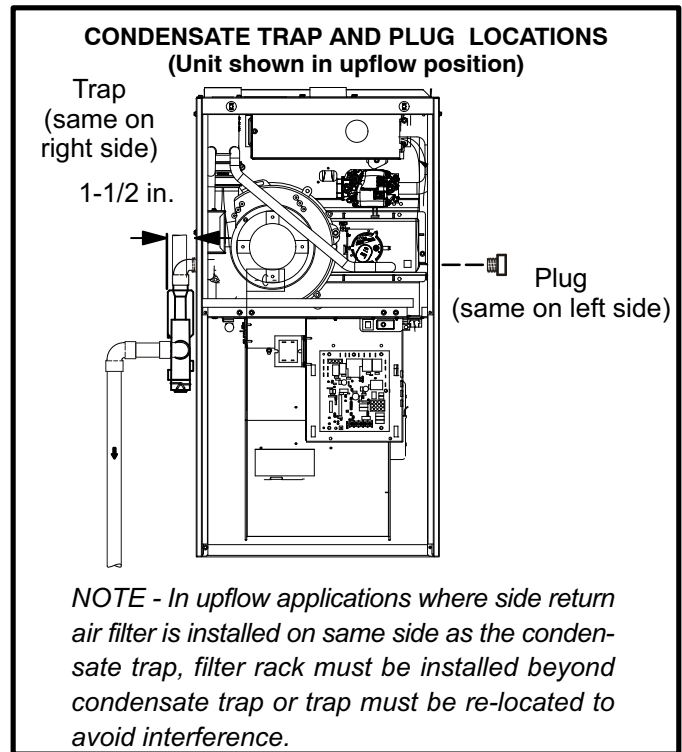

FIGURE 41

NOTE - In horizontal applications it is recommended to install a secondary drain pan underneath the unit and trap assembly.

NOTE - Appropriately sized tubing and barbed fitting may be used for condensate drain. Attach to the drain on the trap using a hose clamp. See figure 42.

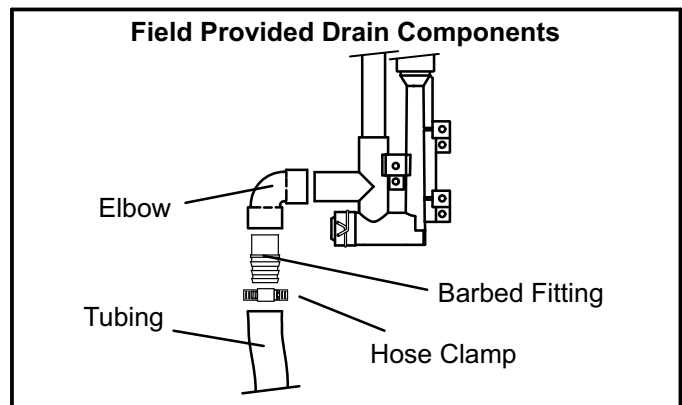

FIGURE 42

⚠ CAUTION

Do not use copper tubing or existing copper condensate lines for drain line.

- 6 - If unit will be started immediately upon completion of installation, prime trap per procedure outlined in Unit Start-Up section.

Condensate line must slope downward away from the trap to drain. If drain level is above condensate trap, condensate pump must be used. Condensate drain line should be routed within the conditioned space to avoid freezing of condensate and blockage of drain line. If this is not possible, a heat cable kit may be used on the condensate trap and line. Heating cable kit is available from Lennox in various lengths; 6 ft. (1.8m) - kit no. 26K68; 24 ft. (7.3m) - kit no. 26K69; and 50 ft. (15.2m) - kit no. 26K70.

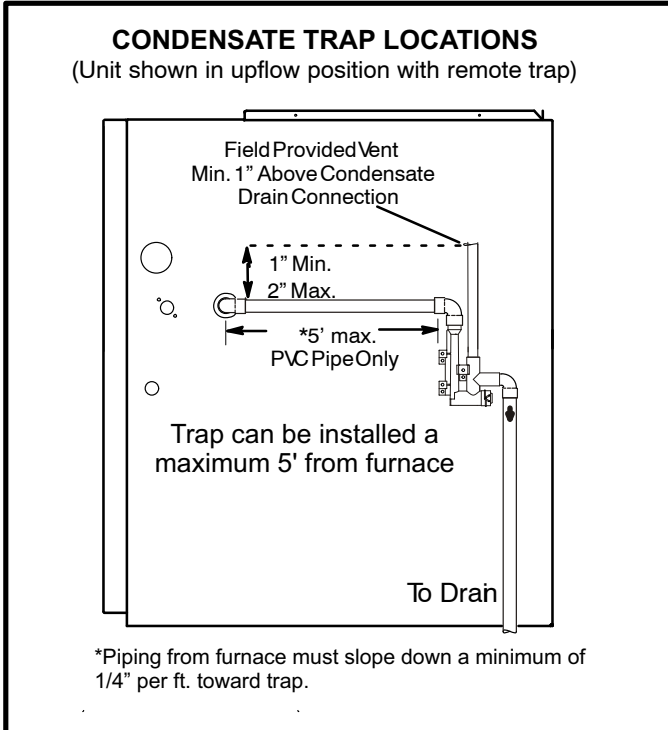

FIGURE 43

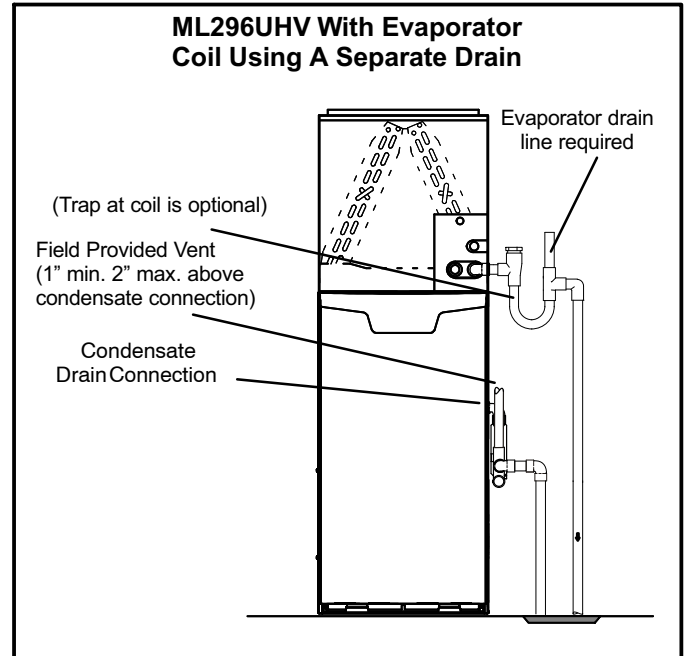

FIGURE 44

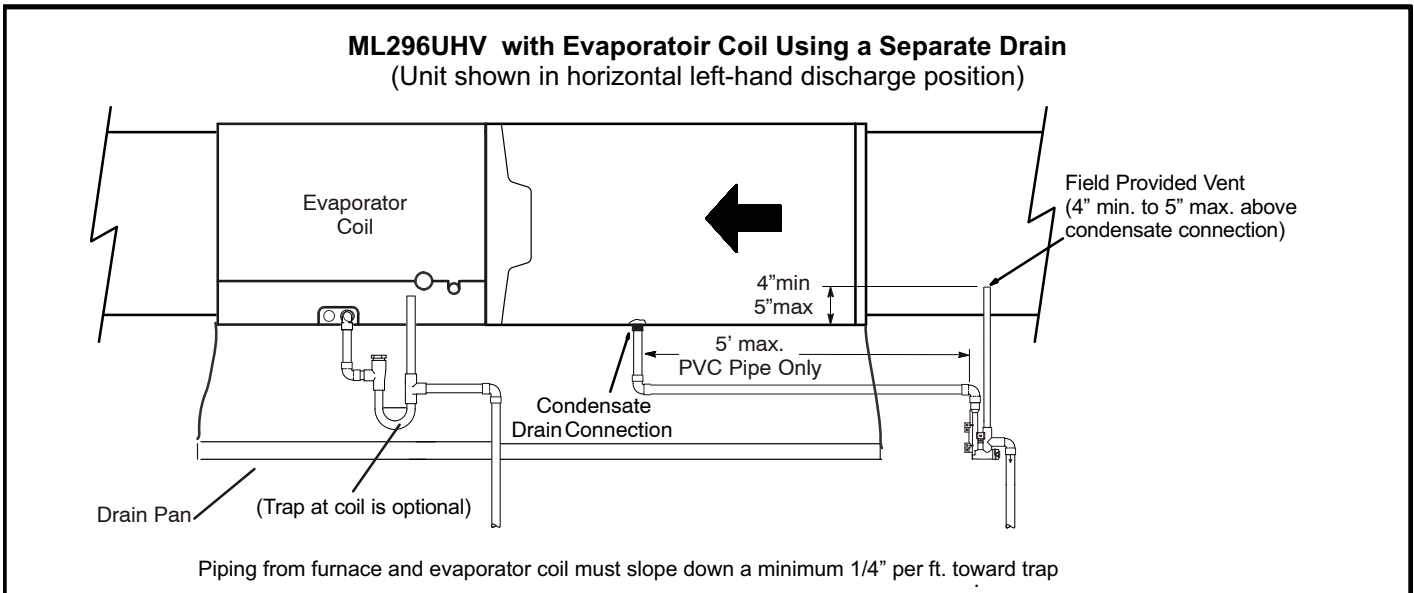

FIGURE 45

⚠ IMPORTANT

When combining the furnace and evaporator coil drains together, the A/C condensate drain outlet must be vented to relieve pressure in order for the furnace pressure switch to operate properly.

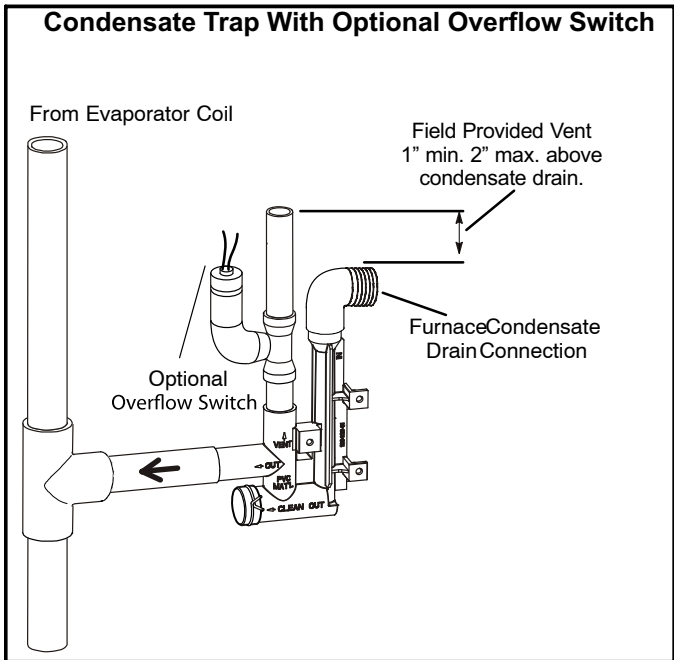

FIGURE 46

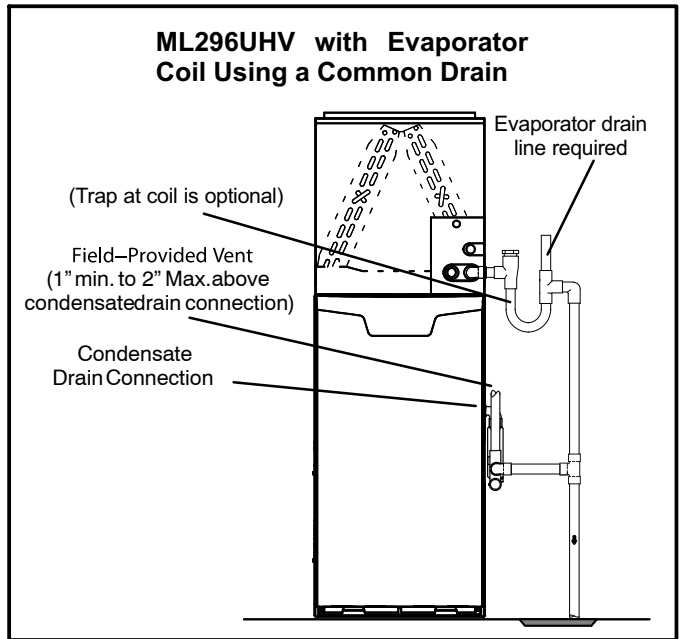

FIGURE 47

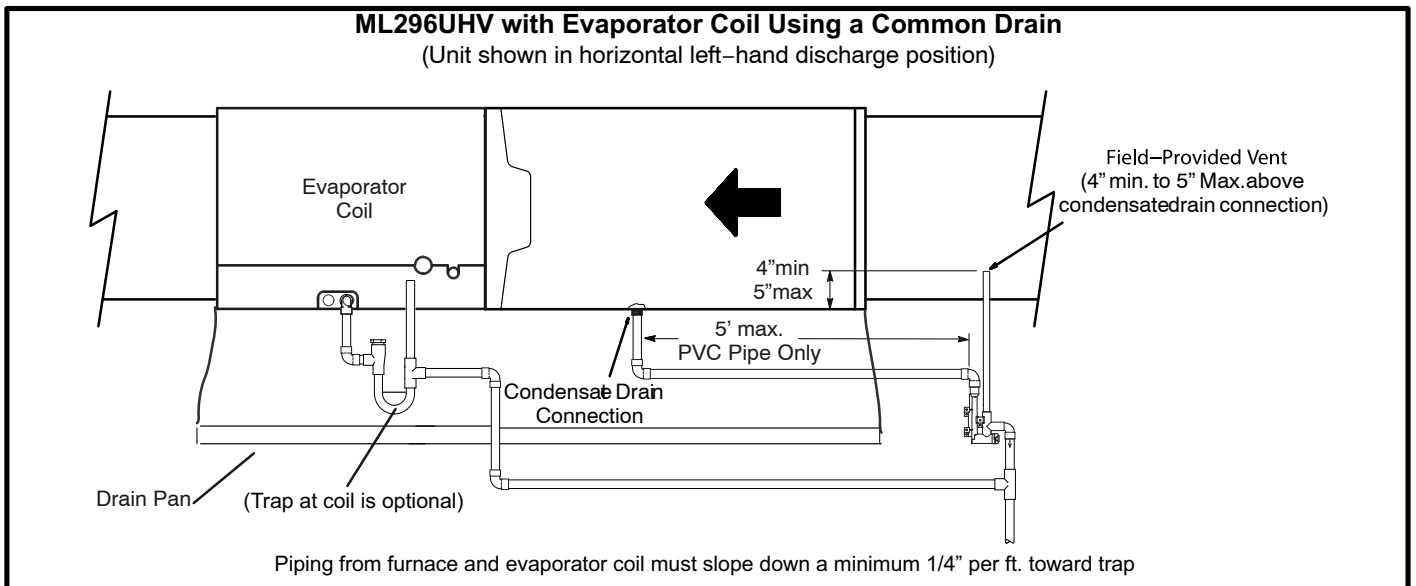
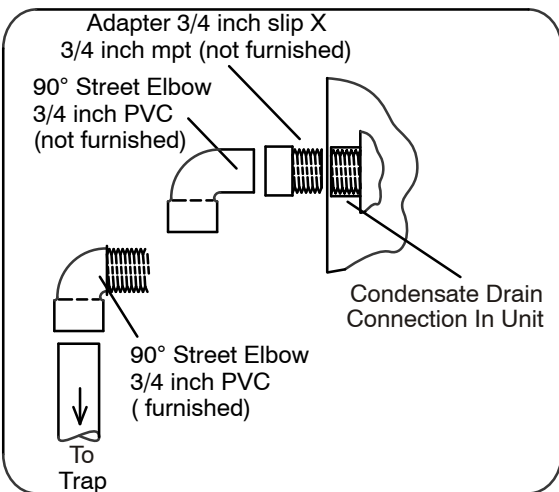

FIGURE 48

TRAP / DRAIN ASSEMBLY USING 1/2" PVC OR 3/4" PVC

Optional Condensate Drain Connection



Optional Drain Piping From Trap

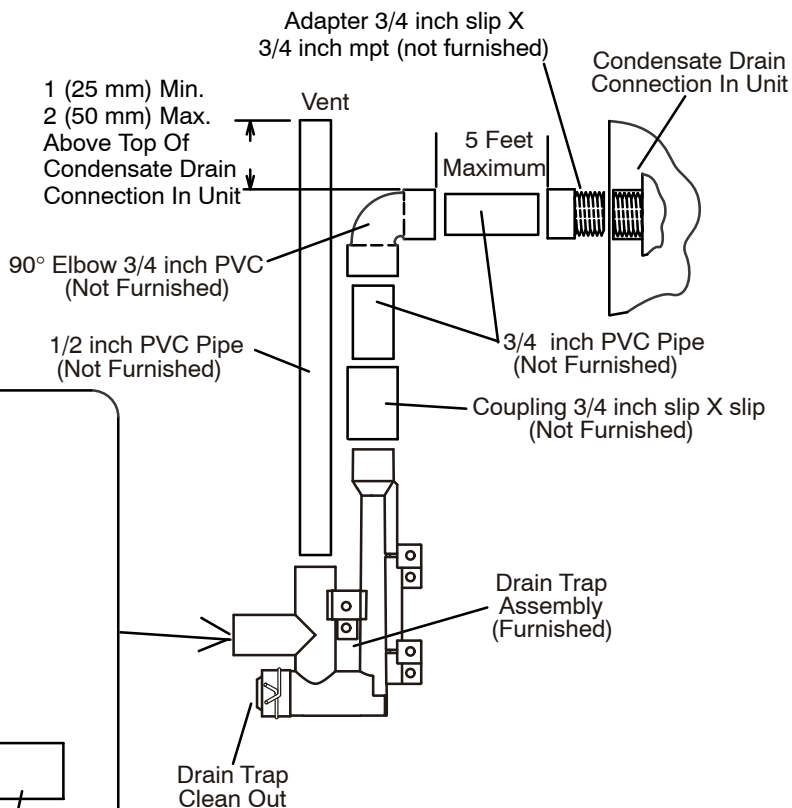
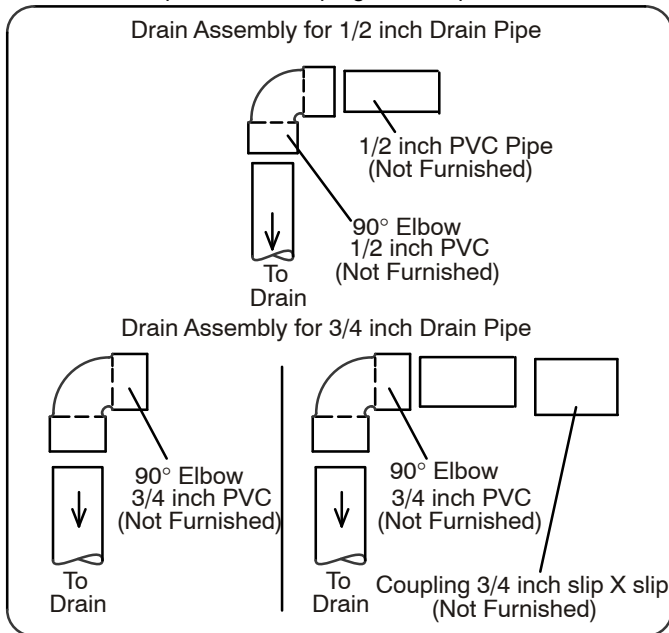

Drain Trap Assembly with 1/2 inch Piping

1 (25 mm) Min. 2 (50 mm) Max. Above Top Of Condensate Drain Connection In Unit

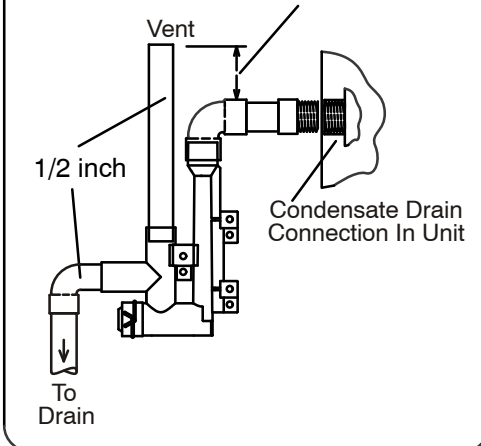

Drain Trap Assembly with 3/4 inch Piping

1 (25 mm) Min. 2 (50 mm) Max. Above Top Of Condensate Drain Connection In Unit

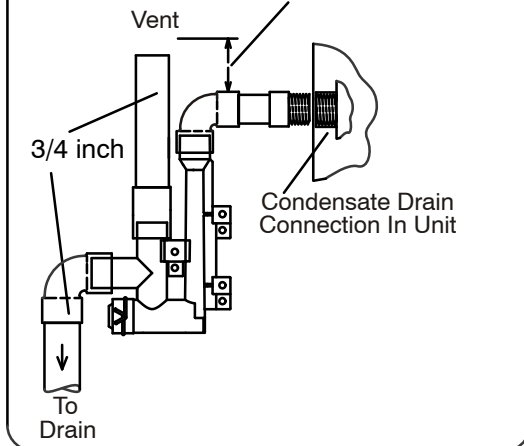

Drain Trap Assembly (Furnished)

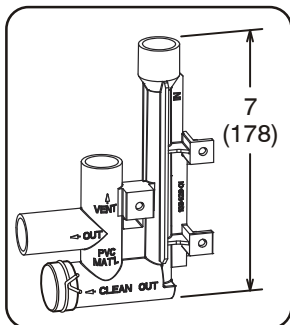

FIGURE 49

III-START-UP

A-Preliminary and Seasonal Checks

- 1 - Inspect electrical wiring, both field and factory installed for loose connections. Tighten as required.
- 2 - Check voltage at disconnect switch. Voltage must be within range listed on the nameplate. If not, consult the power company and have voltage condition corrected before starting unit.
- 3 - Inspect condition of condensate traps and drain assembly. Disassemble and clean seasonally.

B-Heating Start-Up

BEFORE LIGHTING the unit, smell all around the furnace area for gas. Be sure to smell next to the floor because some gas is heavier than air and will settle on the floor.

The gas valve on the ML296UHV is equipped with a gas control switch. Use only your hand to move the switch. Never use tools. If the the switch will not move by hand, replace the valve. Do not try to repair it. Force or attempted repair may result in a fire or explosion.

Placing the furnace into operation:

ML296UHV units are equipped with a SureLight® ignition system. Do not attempt to manually light burners on this furnace. Each time the thermostat calls for heat, the burners will automatically light. The ignitor does not get hot when there is no call for heat on units with SureLight ignition system.

Priming Condensate Trap

The condensate trap should be primed with water prior to start-up to ensure proper condensate drainage. Either pour 10 fl. oz. (300 ml) of water into the trap, or follow these steps to prime the trap:

- 1 - Follow the lighting instructions to place the unit into operation.
- 2 - Set the thermostat to initiate a heating demand.
- 3 - Allow the burners to fire for approximately 3 minutes.
- 4 - Adjust the thermostat to deactivate the heating demand.
- 5 - Wait for the combustion air inducer to stop. Set the thermostat to initiate a heating demand and again allow the burners to fire for approximately 3 minutes.
- 6 - Adjust the thermostat to deactivate the heating demand and again wait for the combustion air inducer to stop. At this point, the trap should be primed with sufficient water to ensure proper condensate drain operation.

⚠ WARNING

If you do not follow these instructions exactly, a fire or explosion may result causing property damage, personal injury or death.

Gas Valve Operation (Figure 50)

- 1 - **STOP!** Read the safety information at the beginning of this section.
- 2 - Set the thermostat to the lowest setting.
- 3 - Turn off all electrical power to the unit.

- 4 - This furnace is equipped with an ignition device which automatically lights the burners. Do **not** try to light the burners by hand.
- 5 - Remove the upper access panel.
- 6 - Move gas valve switch to **OFF**. See figure 50.
- 7 - Wait five minutes to clear out any gas. If you then smell gas, **STOP!** Immediately call your gas supplier from a neighbor's phone. Follow the gas supplier's instructions. If you do not smell gas go to next step.
- 8 - Move gas valve switch to **ON**. See figure 50.

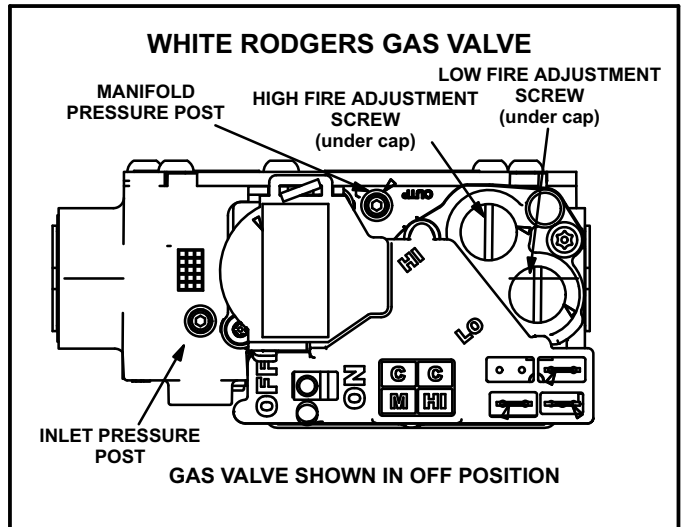

FIGURE 50

- 9 - Replace the upper access panel.
 - 10 - Turn on all electrical power to the unit.
 - 11 - Set the thermostat to desired setting.
- NOTE** - When unit is initially started, steps 1 through 11 may need to be repeated to purge air from gas line.
- 12 - If the appliance will not operate, follow the instructions "Turning Off Gas to Unit" and call your service technician or gas supplier.

Turning Off Gas to Unit

- 1 - Set the thermostat to the lowest setting.
- 2 - Turn off all electrical power to the unit if service is to be performed.
- 3 - Remove the upper access panel.
- 4 - Move gas valve switch to **OFF**.
- 5 - Replace the upper access panel.

Failure To Operate

If the unit fails to operate, check the following:

- 1 - Is the thermostat calling for heat?
- 2 - Are access panels securely in place?
- 3 - Is the main disconnect switch closed?
- 4 - Is there a blown fuse or tripped breaker?
- 5 - Is the filter dirty or plugged? Dirty or plugged filters will cause the limit control to shut the unit off.
- 6 - Is gas turned on at the meter?
- 7 - Is the manual main shut-off valve open?
- 8 - Is the internal manual shut-off valve open?
- 9 - Is the unit ignition system in lockout? If the unit locks out again, inspect the unit for blockages.

IV-HEATING SYSTEM SERVICE CHECKS

A-CSA Certification

All units are CSA design certified without modifications. Refer to the ML296UHV(X) Installation Instruction.

B-Gas Piping

⚠ CAUTION

If a flexible gas connector is required or allowed by the authority that has jurisdiction, black iron pipe shall be installed at the gas valve and extend outside the furnace cabinet.

⚠ WARNING

Do not exceed 600 in-lbs (50 ft-lbs) torque when attaching the gas piping to the gas valve.

Gas supply piping should not allow more than 0.5"W.C. drop in pressure between gas meter and unit. Supply gas pipe must not be smaller than unit gas connection.

Compounds used on gas piping threaded joints should be resistant to action of liquefied petroleum gases.

C-Testing Gas Piping

⚠ IMPORTANT

In case emergency shutdown is required, turn off the main shut-off valve and disconnect the main power to unit. These controls should be properly labeled by the installer.

When pressure testing gas lines, the gas valve must be disconnected and isolated. Gas valves can be damaged if subjected to more than 0.5 psig (14" W.C.). See figure 51. If the pressure is greater than 0.5psig (14"W.C.), use the manual shut-off valve before pressure testing to isolate furnace from gas supply.

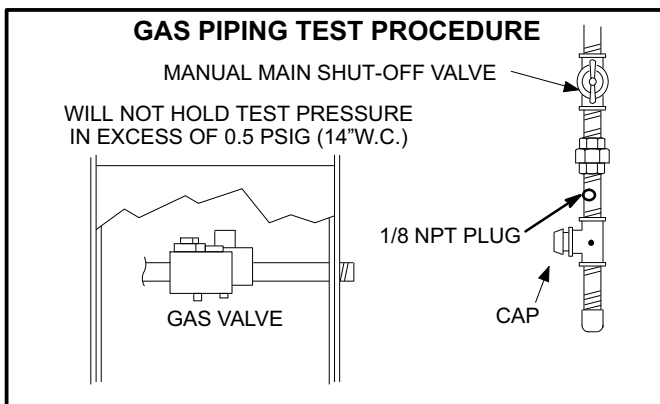

When checking piping connections for gas leaks, use preferred means. Kitchen detergents can cause harmful corrosion on various metals used in gas piping. Use of a specialty Gas Leak Detector is strongly recommended. It is available

through Lennox under part number 31B2001. See Corp. 8411-L10, for further details.

Do not use matches, candles, flame or any other source of ignition to check for gas leaks.

D-Testing Gas Supply Pressure

An inlet pressure post located on the gas valve provides access to the supply pressure. See figure 50. Back out the 3/32 hex screw one turn, connect a piece of 5/16 tubing and connect to a manometer to measure supply pressure. See table 21 for supply line pressure.

E-Check Manifold Pressure

NOTE - Pressure test adapter kit (10L34) is available from Lennox to facilitate manifold pressure measurement.

A manifold pressure post located on the gas valve provides access to the manifold pressure. See figure 50. Back out the 3/32 hex screw one turn, connect a piece of 5/16 tubing and connect to a manometer to measure manifold pressure.

To correctly measure manifold pressure, the differential pressure between the positive gas manifold and the negative burner box must be considered.

⚠ IMPORTANT

For safety, connect a shut-off valve between the manometer and the gas tap to permit shut off of gas pressure to the manometer.

- 1 - Connect the test gauge positive side "+" to manifold pressure tap on gas valve as noted above.
- 2 - Tee into the gas valve regulator vent hose and connect to test gauge negative "-".
- 3 - Ignite unit on low fire and let run for 5 minutes to allow for steady state conditions.
- 4 - After allowing unit to stabilize for 5 minutes, record low fire manifold pressure and compare to value given in table 21. If necessary, make adjustment. Figure 50 shows location of low fire adjustment screw.
- 5 - Repeat on high fire and compare to value given in table 21. If necessary, make adjustment. Figure 50 shows location of high fire adjustment screw.
- 6 - Shut unit off and remove manometer as soon as an accurate reading has been obtained.
- 7 - Start unit and perform leak check. Seal leaks if found.

The gas valve is factory set and should not require adjustment. All gas valves are factory regulated.

F- Proper Gas Flow (Approximate)

Furnace should operate at least 5 minutes before checking gas flow. Determine time in seconds for **two** revolutions of gas through the meter. (Two revolutions assures a more accurate time.) **Divide by two** and compare to time in table 18 below. If manifold pressure matches table 21 and rate is incorrect, check gas orifices for proper size and restriction.

NOTE- To obtain accurate reading, shut off all other gas appliances connected to meter.

TABLE 18

GAS METER CLOCKING CHART				
ML296 Unit	Seconds for One Revolution			
	Natural		LP	
	1 cu ft Dial	2 cu ft Dial	1 cu ft Dial	2 cu ft DIAL
-045	80	160	200	400
-70	55	110	136	272
-90	41	82	102	204
-110	27	54	68	136
Natural-1000 btu/cu ft			LP-2500 btu/cu ft	

Furnace should operate minimum 15 minutes with correct manifold pressure and gas flow rate before checking combustion. See sections E- and F-. Take combustion sample beyond the flue outlet. Table 19 shows acceptable combustions. **The maximum carbon monoxide reading should not exceed 100 ppm.**

TABLE 19

ML296 Model	CO₂% For Nat		CO₂% For L.P	
	Low Fire	High Fire	Low Fire	High Fire
045	5.4 - 6.4	7.5 - 8.5	6.4 - 7.4	8.8 - 9.8
070	5.3 - 6.3	7.4 - 8.4	6.3 - 7.3	8.7 - 9.7
090	5.8 - 6.8	7.6 - 8.6	6.8 - 7.8	8.9 - 9.9
110	6.1 - 7.1	8.0 - 9.0	7.1 - 8.1	9.3 - 10.3

The maximum carbon monoxide reading should not exceed 100ppm.

⚠ IMPORTANT

For safety, shut unit off and remove manometer as soon as an accurate reading has been obtained. Take care to replace pressure tap plug.

H- High Altitude

The manifold pressure, gas orifice and pressure switch may require adjustment or replacement to ensure proper operation at higher altitudes. See table 20 for gas conversion and pressure switch kits. See table 21 for manifold pressures

G- Proper Combustion

TABLE 20

LP/Propane Conversion Kit and Pressure Switch Requirements at Varying Altitudes

ML296 Unit	Natural to LP/Propane	High Altitude Natural Burner Orifice Kit	High Altitude LP/Propane Burner Orifice Kit	High Altitude Pressure Switch	
	0 - 7500 ft (0 - 2286m)	7501 - 10,000 ft (2286 - 3038m)	7501 - 10,000 ft (2286 - 3038m)	4501 - 7500 ft (1373 - 2286m)	7501 -10,000 ft (2286 - 3048m)
-045	*11K51	73W37	*11K46	14A47	14A50
-070				14A54	14A53
-090				14A57	14A54
-110				14A46	14A51

* Conversion requires installation of a gas valve manifold spring which is provided with the gas conversion kit. Pressure switch is factory set. No adjustment necessary. All models use the factory-installed pressure switch from 0-4500 feet (0-1370 m).

TABLE 21

Manifold Pressure Settings

ML296 Unit	Gas	Manifold Pressure in. wg.										Supply Line Pressure in. w.g. 0 - 10000 ft.	
		0-4500 ft.		4501-5500 ft.		5501-6500 ft.		6501 - 7500ft.		7501 - 10000ft.		Min	Max
		Low Fire	High Fire	Low Fire	High Fire	Low Fire	High Fire	Low Fire	High Fire	Low Fire	High Fire		
All Sizes	Natural	1.7	3.5	1.6	3.3	1.5	3.2	1.5	3.1	1.7	3.5	4.5	13.0
	LP/propane	4.5	10.0	4.2	9.4	4.0	9.1	3.9	8.9	4.5	10.0	11.0	13.0

NOTE -A natural to L.P. propane gas changeover kit is necessary to convert this unit. Refer to the changeover kit installation instruction for the conversion procedure.

I- Proper Ground and Voltage

A poorly grounded furnace can contribute to premature ignitor failure. Use the following procedure to check for ground and voltage to the integrated control.

- 1 - Measure the AC voltage between Line Neutral (spade terminals) and "C" terminal (low voltage terminal block) on the integrated control. See figure 52. A wide variation in the voltage between Line Neutral and "C" as a function of load indicates a poor or partial ground. Compare the readings to the table below. If the readings exceed the maximum shown in table 1, make repairs before operating the furnace.

- 2 - In addition, measure the AC voltage from Line Hot to Line Neutral (spade terminals) on the integrated control. See figure 52. This voltage should be in the range of 97 to 132 Vac

TABLE 22

Furnace Status	Measurement VAC	
	Expected	Maximum
Power On Furnace Idle	0.3	2
CAI / Ignitor Energized	0.75	5
Indoor Blower Energized	Less than 2	10

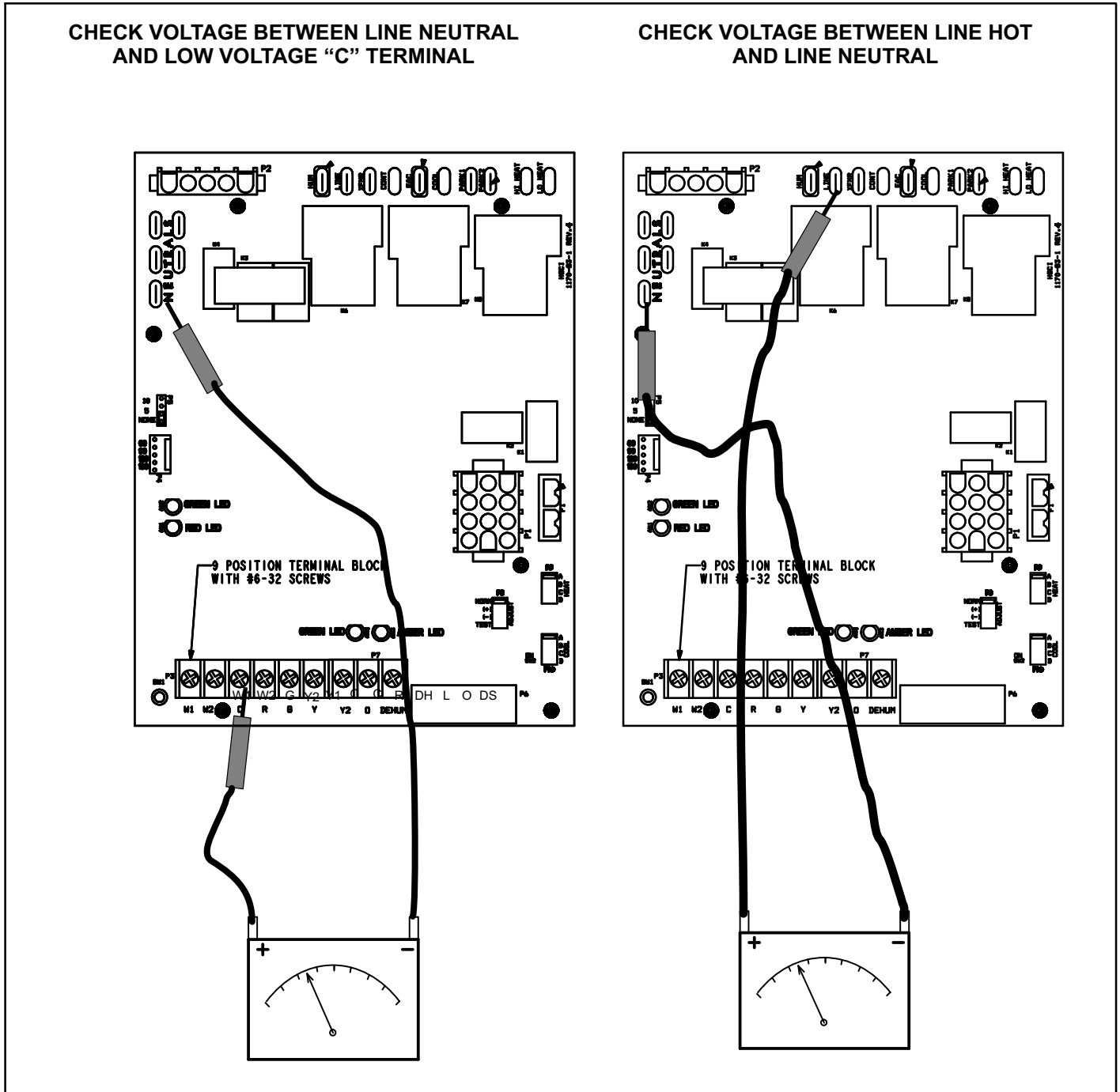

FIGURE 52

V-TYPICAL OPERATING CHARACTERISTICS

A-Blower Operation and Adjustment

- 1 - Blower operation is dependent on thermostat control system.
- 2 - Generally, blower operation is set at thermostat sub-base fan switch. With fan switch in ON position, blower operates continuously. With fan switch in AUTO position, blower cycles with demand or runs continuously while heating or cooling circuit cycles.
- 3 - Depending on the type of indoor thermostat, blower and entire unit will be off when the system switch is in OFF position.

B-Temperature Rise (Figure 53)

Temperature rise for ML296UHV units depends on unit input, blower speed, blower horsepower and static pressure as marked on the unit rating plate. The blower speed must be set for unit operation within the range of "TEMP. RISE °F" listed on the unit rating plate.

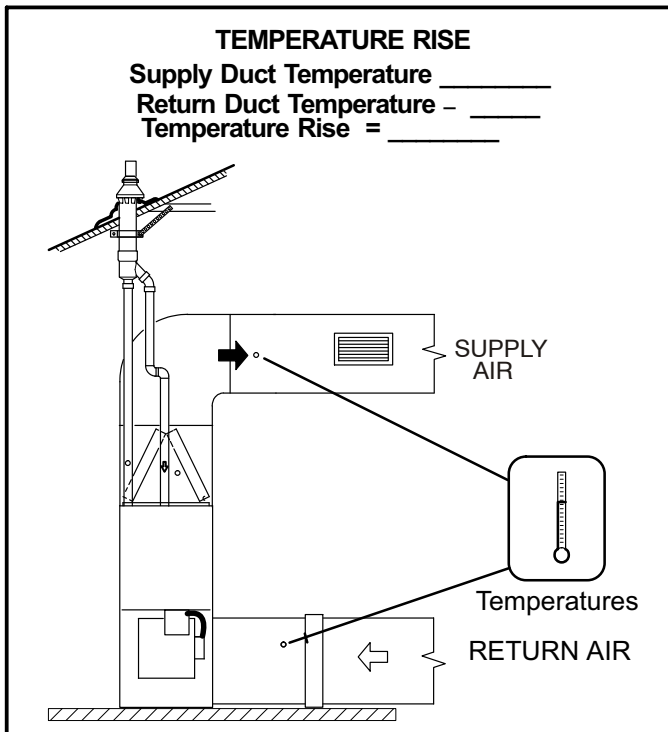

FIGURE 53

C-External Static Pressure

- 1 - Tap locations shown in figure 54.
- 2 - Punch a 1/4" diameter hole in supply and return air plenums. Insert manometer hose flush with inside edge of hole or insulation. Seal around the hose with perma-gum. Connect the zero end of the manometer to the discharge (supply) side of the system. On ducted systems, connect the other end of manometer to the return duct as above.

- 3 - With only the blower motor running and the evaporator coil dry, observe the manometer reading. Adjust blower motor speed to deliver the air desired according to the job requirements. For heating speed (second stage heat speed) external static pressure drop must not be more than 0.8" W.C. For cooling speed (second stage cool speed) external static pressure drop must not be more than 1.0" W.C.
- 4 - Seal the hole when the check is complete.

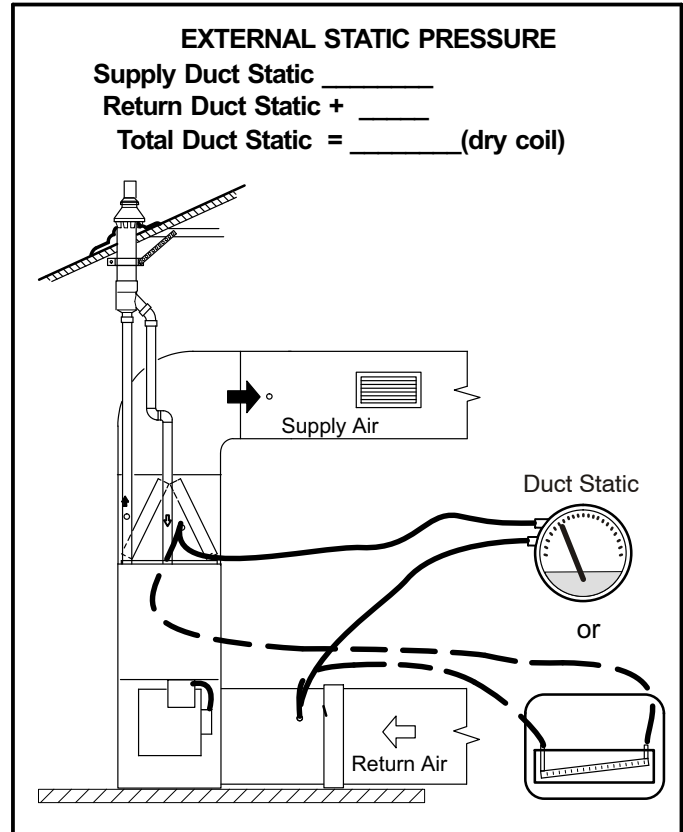

FIGURE 54

VI-MAINTENANCE

⚠ WARNING

**ELECTRICAL SHOCK, FIRE,
OR EXPLOSION HAZARD.**

Failure to follow safety warnings exactly could result in dangerous operation, serious injury, death or property damage.

Improper servicing could result in dangerous operation, serious injury, death, or property damage.

Before servicing, disconnect all electrical power to furnace.

When servicing controls, label all wires prior to disconnecting. Take care to reconnect wires correctly. Verify proper operation after servicing.

At the beginning of each heating season, system should be checked as follows by a qualified service technician:

Blower

Check the blower wheel for debris and clean if necessary. The blower motors are prelubricated for extended bearing life. No further lubrication is needed.

⚠ WARNING

The blower access panel must be securely in place when the blower and burners are operating. Gas fumes, which could contain carbon monoxide, can be drawn into living space resulting in personal injury or death.

Filters

All air filters are installed external to the unit. Filters should be inspected monthly. Clean or replace the filters when necessary to ensure proper furnace operation. Table 23 lists recommended filter sizes.

⚠ IMPORTANT

If a high-efficiency filter is being installed as part of this system to ensure better indoor air quality, the filter must be properly sized. High-efficiency filters have a higher static pressure drop than standard-efficiency glass/foam filters. If the pressure drop is too great, system capacity and performance may be reduced. The pressure drop may also cause the limit to trip more frequently during the winter and the indoor coil to freeze in the summer, resulting in an increase in the number of service calls.

Before using any filter with this system, check the specifications provided by the filter manufacturer against the data given in the appropriate Lennox Product Specifications bulletin. Additional information is provided in Service and Application Note ACC-00-2 (August 2000).

TABLE 23

Furnace Cabinet Width	Minimum Filter Size
17-1/2"	16 x 25 x 1 (1)
21"	

Exhaust and air intake pipes

Check the exhaust and air intake pipes and all connections for tightness and to make sure there is no blockage.

NOTE - After any heavy snow, ice or frozen fog event the furnace vent pipes may become restricted. Always check the vent system and remove any snow or ice that may be obstructing the plastic intake or exhaust pipes.

Electrical

- 1 - Check all wiring for loose connections.
- 2 - Check for the correct voltage at the furnace (furnace operating).
- 3 - Check amp-draw on the blower motor.
Motor Nameplate _____ Actual _____

Winterizing and Condensate Trap Care

- 1 - Turn off power to the furnace.
- 2 - Have a shallow pan ready to empty condensate water.
- 3 - Remove the clean out cap from the condensate trap and empty water. Inspect the trap then reinstall the clean out cap.

Condensate Hose Screen (Figure 55)

Check the condensate hose screen for blockage and clean if necessary.

- 1 - Turn off power to the unit.
- 2 - Remove hose from cold end header box. Twist and pull screen to remove.
- 3 - Inspect screen and rinse with tap water if needed.
- 4 - Reinstall screen and turn on power to unit.

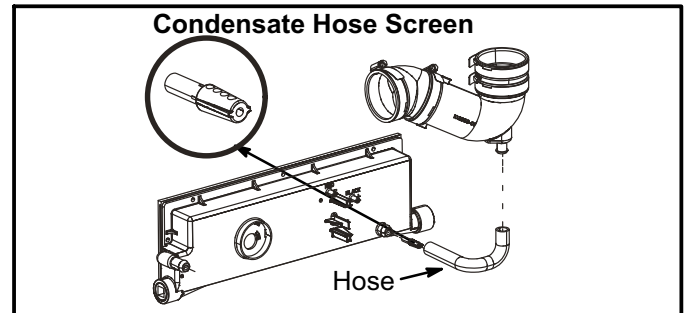

FIGURE 55

Cleaning Heat Exchanger

If cleaning the heat exchanger becomes necessary, follow the below procedures and refer to figure 1 when disassembling unit. Use papers or protective covering in front of furnace while removing heat exchanger assembly.

- 1 - Turn off electrical and gas supplies to the furnace.
- 2 - Remove the furnace access panels.
- 3 - Disconnect the 2 wires from the gas valve.
- 4 - Remove gas supply line connected to gas valve. Remove the burner box cover (if equipped) and remove gas valve/manifold assembly.
- 5 - Remove sensor wire from sensor. Disconnect 2-pin plug from the ignitor.
- 6 - Disconnect wires from flame roll-out switches.
- 7 - Disconnect combustion air intake pipe. It may be necessary to cut the existing pipe to remove burner box assembly.
- 8 - Remove four burner box screws at the vestibule panel and remove burner box. Set burner box assembly aside.
NOTE - If necessary, clean burners at this time. Follow procedures outlined in Burner Cleaning section.
- 9 - Loosen the clamps to the flexible exhaust coupling.
- 10 - Disconnect condensate drain line from the cold end header box.
- 11 - Disconnect condensate drain tubing from flue collar. Remove screws that secures the flue collar into place. Remove flue collar. It may be necessary to cut the exiting exhaust pipe for removal of the fitting.
- 12 - Mark and disconnect all combustion air pressure tubing from cold end header collector box.
- 13 - Mark and remove wires from pressure switch assembly. Remove the assembly. Keep tubing attached to pressure switches.
- 14 - Disconnect the plug from the combustion air inducer. Remove two screws which secure combustion air inducer to collector box. Remove combustion air inducer assembly. Remove ground wire from vest panel.
- 15 - Disconnect the condensate drain line.
- 16 - Remove cold end header box.

- 17 - Remove electrical junction box from the side of the furnace.
- 18 - Mark and disconnect any remaining wiring to heating compartment components. Disengage strain relief bushing and pull wiring and bushing through the hole in the blower deck.
- 19 - Remove the primary limit from the vestibule panel.
- 20 - Remove two screws from the front cabinet flange at the blower deck. Spread cabinet sides slightly to allow clearance for removal of heat exchanger.
- 21 - Remove screws along vestibule sides and bottom which secure vestibule panel and heat exchanger assembly to cabinet. Remove two screws from blower rail which secure bottom heat exchanger flange. Remove heat exchanger from furnace cabinet.
- 22 - Back wash heat exchanger with soapy water solution or steam. **If steam is used it must be below 275°F (135°C) .**
- 23 - Thoroughly rinse and drain the heat exchanger. Soap solutions can be corrosive. Take care to rinse entire assembly.
- 24 - Reinstall heat exchanger into cabinet making sure that the clamshells of the heat exchanger assembly is engaged properly into the support bracket on the blower deck. Remove the indoor blower to view this area through the blower opening.
- 25 - Re-secure the supporting screws along the vestibule sides and bottom to the cabinet.
- 26 - Reinstall cabinet screws on front flange at blower deck.
- 27 - Reinstall the primary limit on the vestibule panel.
- 28 - Route heating component wiring through hole in blower deck and reinsert strain relief bushing.
- 29 - Reinstall electrical junction box.
- 30 - Reinstall the cold end header box.
- 31 - Reinstall the combustion air inducer. Reconnect the plug to the wire harness.
- 32 - Reinstall pressure switches and reconnect pressure switch wiring.
- 33 - Carefully connect combustion air pressure switch tubing from pressure switches to proper ports on cold end header collector box.
- 34 - Reconnect condensate drain line to the cold end header box.
- 35 - Use securing screws to reinstall flue collar to the top cap on the furnace. Reconnect exhaust piping and exhaust drain tubing.
- 36 - Replace flexible exhaust adapter on combustion air inducer and flue collar. Secure using two existing hose clamps.
- 37 - Reinstall burner box assembly in vestibule area. Secure burner box assembly to vestibule panel using four existing screws. **Make sure burners line up in center of burner ports**
- 38 - Reconnect flame roll-out switch wires.
- 39 - Reconnect sensor wire and reconnect 2-pin plug from ignitor.

- 40 - Reinstall gas valve manifold assembly. Reconnect gas supply line to gas valve.
- 41 - Reconnect the combustion air intake pipe.
- 42 - Reinstall burner box cover.
- 43 - Reconnect wires to gas valve.
- 44 - Replace the blower compartment access panel.
- 45 - Reconnect gas supply piping. Turn on power and gas supply to unit.
- 46- Follow lighting instructions on unit nameplate to light and operate furnace for 5 minutes to ensure the furnace is operating properly.
- 47- Check all piping connections, factory and field, for gas leaks. Use a leak detecting solution or other preferred means.
- 48- Replace heating compartment access panel.

CAUTION

Some soaps used for leak detection are corrosive to certain metals. Carefully rinse piping thoroughly after leak test has been completed. Do not use matches, candles, flame or other sources of ignition to check for gas leaks.

Cleaning the Burner Assembly (if needed)

- 1 - Turn off electrical and gas power supplies to furnace. Remove upper and lower furnace access panels.
- 2 - Disconnect the wires from the gas valve.
- 3 - Remove the burner box cover (if equipped).
- 4 - Disconnect the gas supply line from the gas valve. Remove gas valve/manifold assembly.
- 5 - Mark and disconnect sensor wire from the sensor. Disconnect wires from flame rollout switches.
- 6 - Disconnect combustion air intake pipe. It may be necessary to cut the existing pipe to remove burner box assembly.
- 7 - Remove four screws which secure burner box assembly to vest panel. Remove burner box from the unit.
- 8 - Use the soft brush attachment on a vacuum cleaner to gently clean the face of the burners. Visually inspect the inside of the burners and crossovers for any blockage caused by foreign matter. Remove any blockage.
- 9 - Reinstall the burner box assembly using the existing four screws. Make sure that the burners line up in the center of the burner ports.
- 10 - Reconnect the sensor wire and reconnect the 2-pin plug to the ignitor wiring harness. Reconnect wires to flame rollout switches.
- 11 - Reinstall the gas valve manifold assembly. Reconnect the gas supply line to the gas valve. Reinstall the burner box cover.
- 12 - Reconnect wires to gas valve.
- 13 - Replace the blower compartment access panel.
- 14 - Refer to instruction on verifying gas and electrical connections when re-establishing supplies.
- 15 - Follow lighting instructions to light and operate furnace for 5 minutes to ensure that heat exchanger is clean and dry and that furnace is operating properly.
- 16 - Replace heating compartment access panel.

VII- Wiring and Sequence of Operation

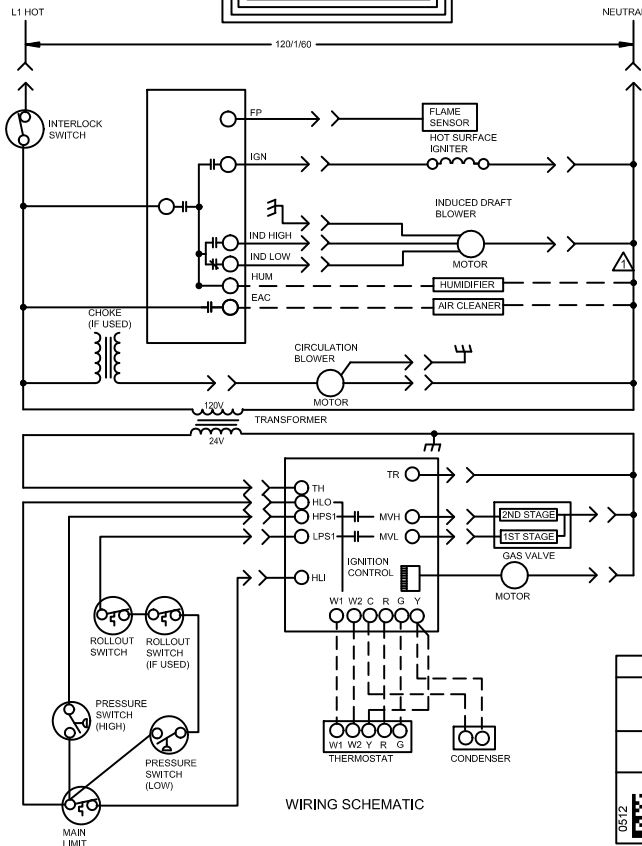
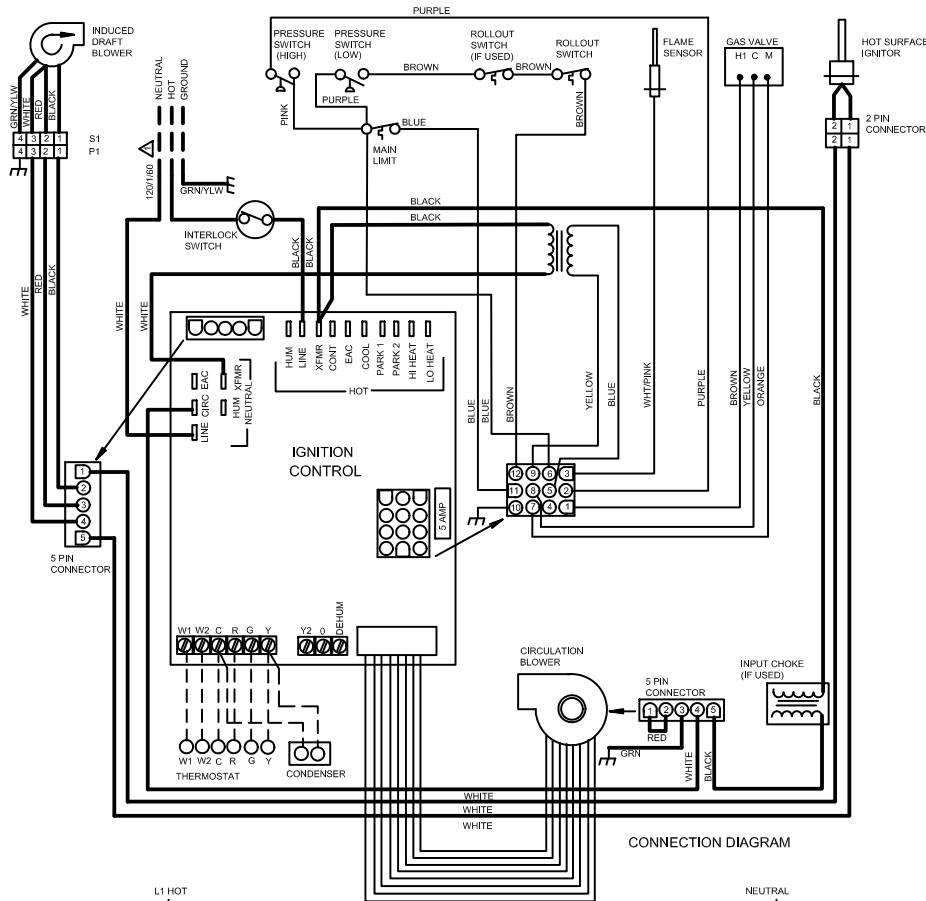

PROPER POLARITY MUST BE OBSERVED FOR FIELD LINE VOLTAGE SUPPLY. IGNITION CONTROL WILL LOCK OUT IF POLARITY IS REVERSED

FOR TEMPORARY SERVICE REPLACEMENT ON CIRCULATING BLOWER MOTOR WITH PSC MOTOR, CONNECT MOTOR LEADS TO "EAC" TERMINALS ON IGNITION CONTROL

WARNING-
ELECTRIC SHOCK HAZARD, CAN CAUSE INJURY OR DEATH. UNIT MUST BE GROUNDED IN ACCORDANCE WITH NATIONAL AND LOCAL CODES.

NOTE-
IF ANY WIRE IN THIS APPLIANCE IS REPLACED IT MUST BE REPLACED WITH WIRE OF LIKE SIZE, RATING, INSULATION THICKNESS, AND TERMINATION

- LINE VOLTAGE FIELD INSTALLED
- LINE VOLTAGE - FACTORY
- - - CLASS II VOLTAGE FIELD WIRING
- LOW VOLTAGE - FACTORY

HEATING UNITS-GAS	
GAS FIRED TWO STAGE FURNACE	
0512	Supersedes 537437-01
Form No. 537567-01	

On a call for heat from the room thermostat, the control board performs a 1 second self check. Upon confirmation that the pressure switch contacts are in an open position, the control energizes the combustion blower on high speed. The control then checks for adequate combustion air by making sure the low-fire pressure switch contacts are closed.

The igniter energizes and is allowed to warm up for 20 seconds before the gas valve energizes on 1st stage and burners ignite. 45 seconds after the control confirms ignition has occurred, the control drops the combustion blower to low speed.

The circulating blower operates at full 1st stage heat speed until either the heat call is satisfied or the thermostat initiates a call for 2nd stage heat. On a call for 2nd stage heat, the control energizes the circulating air blower on full CFM 2nd stage heat.

If the automatic heat staging option is being used the furnace does not switch to 2nd stage heat in response to a call from the thermostat but instead operates at 1st stage heat for the duration of the selected time before automatically switching to 2nd stage heat.

When the call for heat is satisfied, the gas valve and combustion air blower shut down. The control board shuts off the gas valve and runs the combustion blower for an additional 15 seconds. The circulating air blower continues to run the selected heat blower off delay time. before ramping down.

In the event the unit loses ignition, the control will attempt to recycle up to five times before it goes into a 1 hour lockout. Lockout may be manually reset by removing power from the control for more than 1 second or removing the thermostat call for heat for more than 3 seconds.

If during a heating cycle the limit control senses an abnormally high temperature and opens, the control board de-energizes the gas valve and the combustion blower while the circulating blower ramps up to 2nd stage heat speed. The circulating blower remains energized until the limits are closed.

Fan On

When the thermostat is set for continuous fan operation and there is no demand for heating or cooling, a call for fan closes the R to G circuit and the circulating blower motor runs at 50% of the selected cooling CFM until switched off. When the call for fan is turned off, the control de-energizes the circulating blower.

Cooling

The unit is set up at the factory for single stage cooling. For two stage cooling operation, clip the jumper wire located between the Y to Y2 terminals on the integrated ignition/blower control board. If the active dehumidification feature is enabled, the circulating blower runs at 70% of the selected cooling speed as long as there is a call for dehumidification.

⚠ WARNING

The system must not be in either the passive or active dehumidification mode when charging a cooling system.

Single Stage Cooling

A call for cooling from the thermostat closes the R to Y circuit on the integrated ignition/blower control board. The control waits for a 1-second delay before energizing the circulating blower to 82% of the selected cooling CFM (passive dehumidification mode). After 7.5 minutes, the circulating blower automatically ramps up to 100% of the selected cooling airflow. When the call for cooling is satisfied, the circulating blower ramps back down to 82% of the selected cooling airflow for 1 minute, then shuts off.

Two-Stage Cooling

A call for 1st stage cooling from the thermostat closes the R to Y circuit on the control board. The control waits for a 1-second delay before energizing the circulating blower. The blower motor runs at 57% of the selected air flow for the first 7.5 minutes of the 1st stage cooling demand (passive dehumidification mode). After 7.5 minutes, the blower motor runs at 70% of the selected cooling air flow until 1st stage cooling demand is satisfied.

A call for 2nd stage cooling from the thermostat closes the R to Y2 circuit on the control board. The blower motor ramps up to 100% of the selected cooling air flow. When the demand for cooling is met, the blower ramps down to Y1 until satisfied, then ramps down to 57% for 1 minute, then turns off.

Heat Pump

For heat pump operation, clip the jumper wire located below the O terminal on the integrated ignition/blower control board. In heat pump mode, a call for heat will result in the circulating air blower operating at the selected cooling airflow after a brief ramp-up period.