

EL15XP1 (HFC-410A) SERIES OUTDOOR UNITS



⚠ WARNING

Improper installation, adjustment, alteration, service or maintenance can cause property damage, personal injury or loss of life. Installation and service must be performed by a licensed professional HVAC installer or equivalent, service agency, or the gas supplier.

⚠ IMPORTANT

The Clean Air Act of 1990 bans the intentional venting of refrigerant (CFCs, HCFCs and HFCs) as of July 1, 1992. Approved methods of recovery, recycling or reclaiming must be followed. Fines and/or incarceration may be levied for noncompliance.

⚠ IMPORTANT

This unit must be matched with an indoor coil as specified in Lennox Product Specification bulletin. Coils previously charged with HCFC-22 must be flushed.

⚠ CAUTION

As with any mechanical equipment, contact with sharp sheet metal edges can result in personal injury. Take care while handling this equipment and wear gloves and protective clothing.

⚠ WARNING



Electric Shock Hazard. Can cause injury or death. Unit must be properly grounded in accordance with national and local codes.

Line voltage is present at all components when unit is not in operation on units with single-pole contactors. Disconnect all remote electric power supplies before opening access panel. Unit may have multiple power supplies.

Table of Contents

Installation Clearances	2
Model Number Identification	2
Dimensions	3
Specifications	4
Typical Unit Parts Arrangement	6
Operating Gauge Set and Service Valves	6
Unit Placement	8
New or Replacement Line Set	9
Brazing Connections	11
Flushing Line Set and Indoor Coil	14
Installing Indoor Metering Device	15
Leak Test Line Set and Indoor Coil	16
Evacuating Line Set and Indoor Coil	17
Electrical	18
System Operation	20
System Configuration	20
Defrost System	23
Maintenance	25
Wiring and Sequence of Operation	27
Servicing Units Void of Charge	29
Start-Up	29

General Information

These instructions are intended as a general guide and do not supersede national or local codes in any way. Consult authorities having jurisdiction before installation.

This EL15XP1 outdoor heat pump **with all-aluminum coil** is designed for use with HFC-410A refrigerant only. This unit must be installed with an approved indoor air handler or coil. See the Lennox EL15XP1 Product Specifications bulletin (EHB) for approved indoor component match ups. These instructions are intended as a general guide and do not supersede local codes in any way. Consult authorities having jurisdiction before installation.

This outdoor unit is designed for use in systems that use the following refrigerant metering device:

- Check thermal expansion valve (CTXV)

IMPORTANT: Special procedures are required for cleaning the all-aluminum coil in this unit. See page 25 in this instruction for information.

Installation Clearances

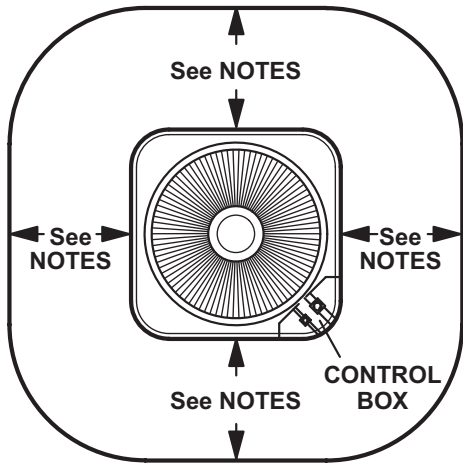

NOTES:

Service clearance of 30 in. (762 mm) must be maintained on one of the sides adjacent to the control box.

Clearance to one of the other three sides must be 36 in. (914 mm)

Clearance to one of the remaining two sides may be 12 in. (305 mm) and the final side may be 6 in. (152 mm).

A clearance of 24 in. must be maintained between two units.
48 in. (1219 mm) clearance required on top of unit.

Model Number Identification

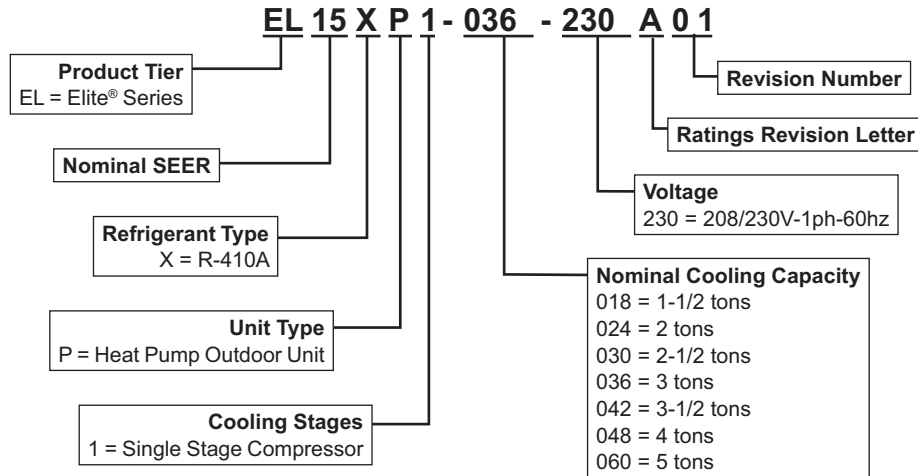

Dimensions

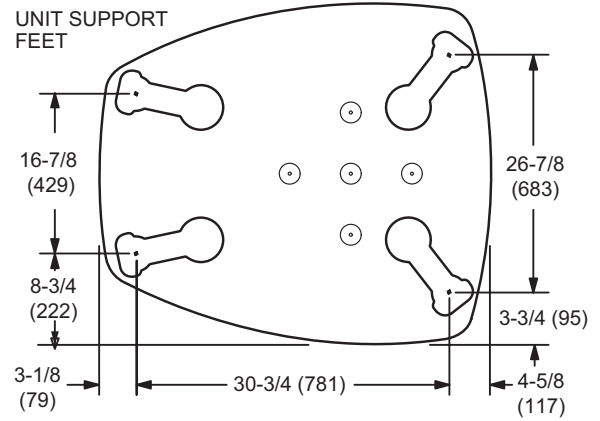
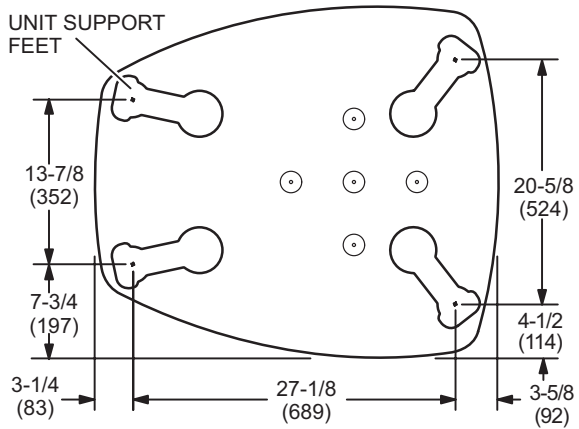
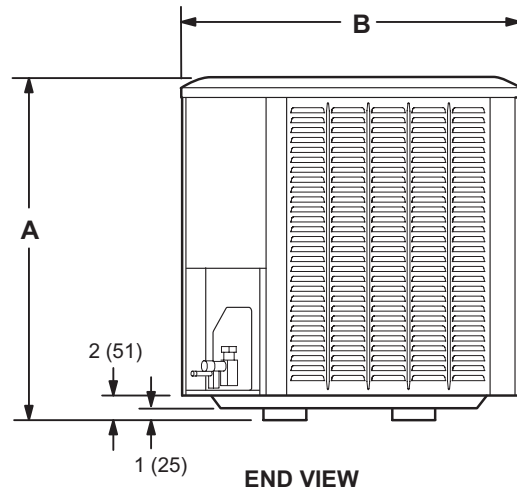
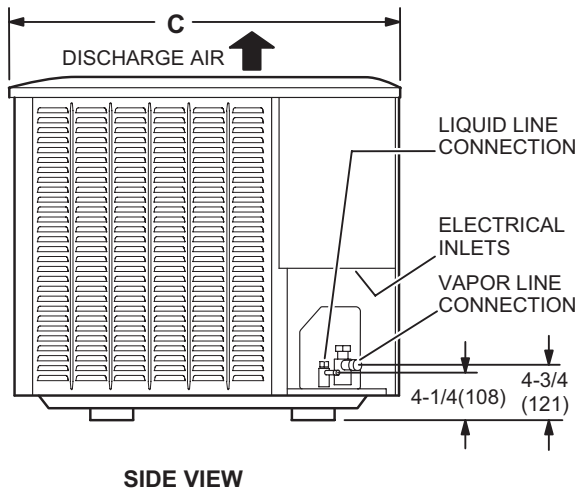
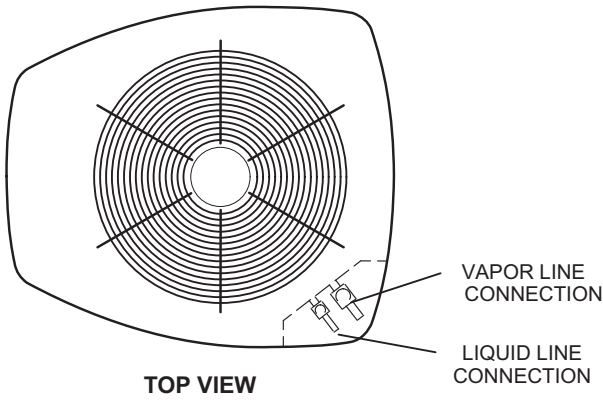

Specifications

General Data		Model No.	EL15XP1-018	EL15XP1-024	EL15XP1-030	EL15XP1-036	
		Nominal Tonnage	1.5	2	2.5	3	
¹ Sound Rating Number			71	71	71	72	
Connections (sweat)		Liquid line (o.d.) - in.	3/8	3/8	3/8	3/8	
		Suction line (o.d.) - in.	3/4	3/4	3/4	7/8	
² Refrigerant		R-410A charge furnished	7 lbs. 0 oz.	7 lbs. 2 oz.	7 lbs 3 oz.	8 lbs. 10 oz.	
Outdoor Coil		Net face area - sq. ft.	24.5	24.5	24.5	21.0	
		Outer coil	24.5	24.5	24.5	21.0	
		Inner coil	---	---	---	20.3	
		Tube diameter - in.	5/16	5/16	5/16	5/16	
		No. of rows	1	1	1	2	
		Fins per inch	22	22	22	22	
Outdoor Fan		Diameter - in.	22	22	22	22	
		No. of blades	3	3	3	3	
		Motor hp	1/6	1/6	1/6	1/6	
		Cfm	2670	2670	2890	2870	
		Rpm	867	867	847	839	
		Watts	160	160	200	205	
Shipping Data - lbs. 1 pkg.			213	213	213	229	
ELECTRICAL DATA							
Line voltage data - 60hz			208/230V-1ph	208/230V-1ph	208/230V-1ph	208/230V-1ph	
³ Maximum overcurrent protection (amps)			20	20	25	30	
⁴ Minimum circuit ampacity			12.2	13.6	17.0	18.6	
Compressor		Rated load amps	9.0	10.1	12.8	14.1	
		Locked rotor amps	48	52	67.8	72.2	
		Power factor	.98	.98	.96	.99	
Outdoor Fan Motor		Full load amps	1.0	1.0	1.0	1.0	
		Locked rotor amps	1.9	1.9	1.9	1.9	
CONTROLS							
iComfort® E30 Smart Wi-Fi Thermostat		15S63	•	•	•	•	
Remote Outdoor Temperature Sensor		X2658	•	•	•	•	
OPTIONAL ACCESSORIES - ORDER SEPARATELY							
Compressor Crankcase Heater		93M04	•	•	•	Factory	
Compressor Hard Start Kit		Copeland	10J42			•	
		LG	88M91	•	•	•	
Compressor Low Ambient Cut-Off Switch		45F08	•	•	•	•	
Freezestat		3/8 in. tubing	93G35	•	•	•	
		5/8 in. tubing	50A93	•	•	•	•
Indoor Blower Off Delay Relay		58M81	•	•	•	•	
⁵ Low Ambient Kit		54M89	•	•	•	•	
Mild Weather Kit		11B97	•	•	•	•	
Monitor Kit - Service Light		76F53	•	•	•	•	
Outdoor Thermostat Kit		Thermostat	10Z23	•		•	
		Mounting Box	31461	•		•	
Refrigerant Line Sets		L15-41-20	L15-41-40	•	•	•	
		L15-41-30	L15-41-50	•	•	•	
		L15-65-30	L15-65-40				•
		L15-65-50	L15-65-50				•
⁶ Snow Guard 35-1/2 x 31 in. (Canada Only)		X8780	•	•	•	•	

NOTE - Extremes of operating range are plus 10% and minus 5% of line voltage.

¹ Sound Rating Number rated in accordance with test conditions included in AHRI Standard 270.

² Refrigerant charge sufficient for 15 ft. length of refrigerant lines. For longer line set requirements see the Installation Instructions for information about line set length and additional refrigerant charge required.

³ HACR type breaker or fuse.

⁴ Refer to National or Canadian Electrical Code manual to determine wire, fuse and disconnect size requirements.

⁵ Crankcase Heater and Freezestat are recommended with Low Ambient Kit.

⁶ Adds 11-1/2 inches (292 mm) to unit height.

SPECIFICATIONS

General Data		Model No.	EL15XP1-042	EL15XP1-048	EL15XP1-060
	Nominal Tonnage		3.5	4	5
¹ Sound Rating Number			72	73	73
Connections (sweat)	Liquid line (o.d.) - in.		3/8	3/8	3/8
	Suction line (o.d.) - in.		7/8	7/8	1-1/8
² Refrigerant	R-410A charge furnished		10 lbs. 11 oz.	10 lbs. 11 oz.	12 lbs. 5 oz.
Outdoor Coil	Net face area - sq. ft.	Outer coil	24.9	24.9	29.1
		Inner coil	24.1	24.1	28.2
		Tube diameter - in.	5/16	5/16	5/16
		No. of rows	2	2	2
		Fins per inch	22	22	22
Outdoor Fan		Diameter - in.	22	22	22
		No. of blades	4	4	4
		Motor hp	1/4	1/4	1/4
		Cfm	4347	4347	4550
		Rpm	843	843	830
		Watts	299	299	307
Shipping Data - lbs. 1 pkg.			285	285	308
ELECTRICAL DATA					
Line voltage data - 60hz			208/230V-1ph	208/230V-1ph	208/230V-1ph
³ Maximum overcurrent protection (amps)			45	45	50
⁴ Minimum circuit ampacity			25.8	26.2	29.6
Compressor		Rated load amps	19.2	19.6	22.2
		Locked rotor amps	123.9	130	127.9
		Power factor	.96	.98	.99
Outdoor Fan Motor		Full load amps	1.8	1.8	1.8
		Locked rotor amps	3.2	3.2	3.2
CONTROLS					
iComfort® E30 Smart Wi-Fi Thermostat		15S63	•	•	•
Remote Outdoor Temperature Sensor		X2658	•	•	•
OPTIONAL ACCESSORIES - ORDER SEPARATELY					
Compressor Hard Start Kit	Copeland	10J42	•	•	
	LG	88M91			•
Compressor Low Ambient Cut-Off Switch		45F08	•	•	•
Freezestat	3/8 in. tubing	93G35	•	•	•
	5/8 in. tubing	50A93	•	•	•
Indoor Blower Off Delay Relay		58M81	•	•	•
⁵ Low Ambient Kit		54M89	•	•	•
Mild Weather Kit		11B97	•	•	•
Monitor Kit - Service Light		76F53	•	•	•
Outdoor Thermostat Kit	Thermostat	10Z23	•	•	•
	Mounting Box	31461	•	•	•
Refrigerant Line Sets	L15-65-30 L15-65-40 L15-65-50		•	•	•
⁶ Snow Guard	39-1/2 X 35-5/8 in.	Y1033	•	•	•

NOTE - Extremes of operating range are plus 10% and minus 5% of line voltage.

¹ Sound Rating Number rated in accordance with test conditions included in AHRI Standard 270.

² Refrigerant charge sufficient for 15 ft. length of refrigerant lines. For longer line set requirements see the Installation Instructions for information about line set length and additional refrigerant charge required.

³ HACR type breaker or fuse.

⁴ Refer to National or Canadian Electrical Code manual to determine wire, fuse and disconnect size requirements.

⁵ Crankcase Heater and Freezestat are recommended with Low Ambient Kit.

⁶ Adds 11-1/2 inches (292 mm) to unit height.

Typical Unit Parts Arrangement

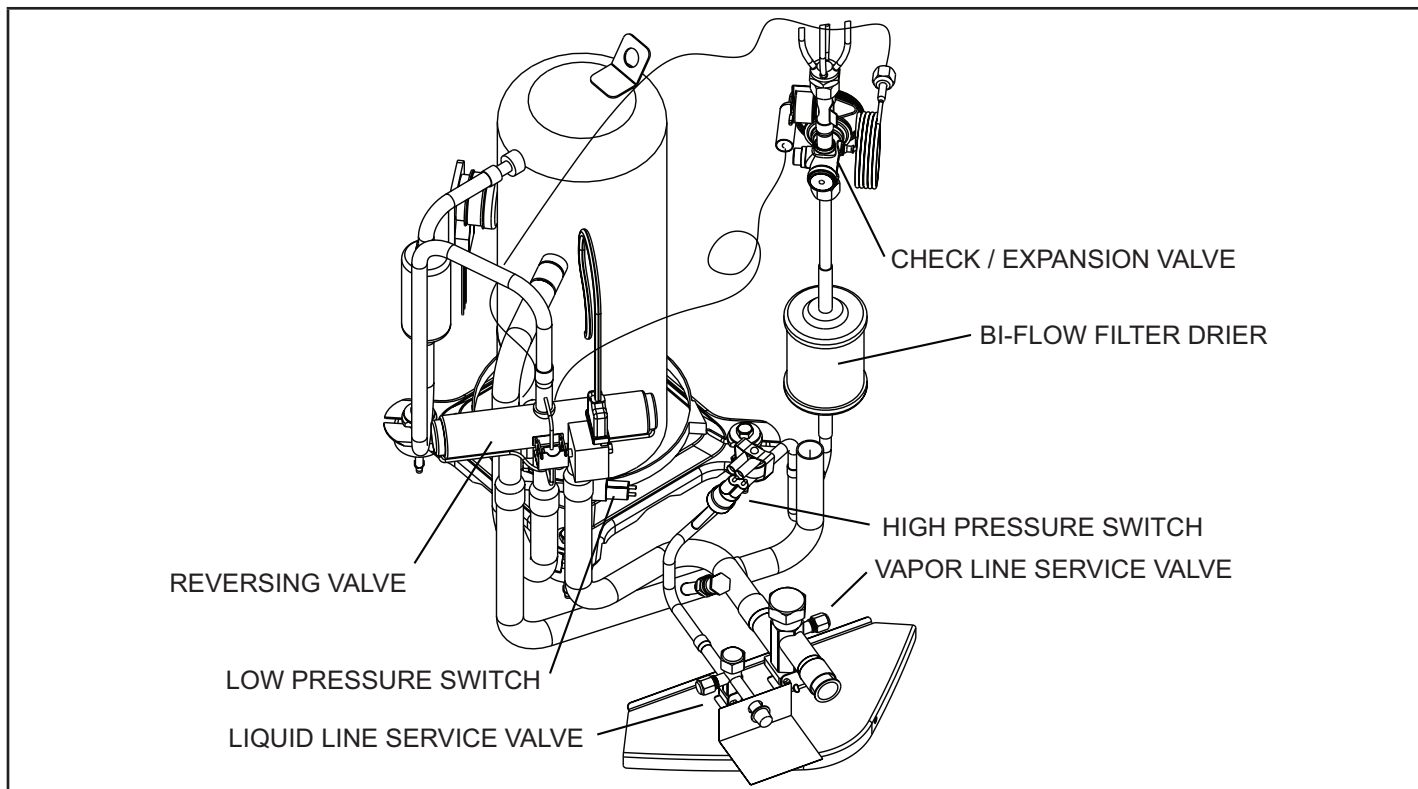

FIGURE 1. Typical Plumbing Arrangement

Operating Gauge Set and Service Valves

TORQUE REQUIREMENTS

When servicing or repairing heating, ventilating, and air conditioning components, ensure the fasteners are appropriately tightened. Table 1 lists torque values for fasteners.

⚠ IMPORTANT

Only use Allen wrenches of sufficient hardness (50Rc - Rockwell Harness Scale minimum). Fully insert the wrench into the valve stem recess.

Service valve stems are factory-torqued (from 9 ft-lbs for small valves, to 25 ft-lbs for large valves) to prevent refrigerant loss during shipping and handling. Using an Allen wrench rated at less than 50Rc risks rounding or breaking off the wrench, or stripping the valve stem recess.

See the Lennox Service and Application Notes #C-08-1 for further details and information.

⚠ IMPORTANT

To prevent stripping of the various caps used, the appropriately sized wrench should be used and fitted snugly over the cap before tightening.

TABLE 1. Torque Requirements

Parts	Recommended Torque	
Service valve cap	8 ft.- lb.	11 NM
Sheet metal screws	16 ft.- lb.	2 NM
Machine screws #10	28 ft.- lb.	3 NM
Compressor bolts	90 in.- lb.	10 NM
Gauge port seal cap	8 ft.- lb.	11 NM

USING MANIFOLD GAUGE SET

When checking the system charge, only use a manifold gauge set that features low loss anti-blow back fittings.

Manifold gauge set used with HFC-410A refrigerant systems must be capable of handling the higher system operating pressures. The gauges should be rated for use with pressures of 0 - 800 psig on the high side and a low side of 30" vacuum to 250 psig with dampened speed to 500 psi. Gauge hoses must be rated for use at up to 800 psig of pressure with a 4000 psig burst rating.

OPERATING SERVICE VALVES

The liquid and vapor line service valves are used for removing refrigerant, flushing, leak testing, evacuating, checking charge and charging. Each valve is equipped with a service port which has a factory-installed valve stem. Figure 2 provides information on access and operation of both angle and ball service valves

SERVICE VALVES ANGLE AND BALL

Operating Angle Type Service Valve:

1. Remove stem cap with an appropriately sized wrench.
2. Use a service wrench with a hex-head extension (3/16" for liquid line valve sizes and 5/16" for vapor line valve sizes) to back the stem out counterclockwise as far as it will go.

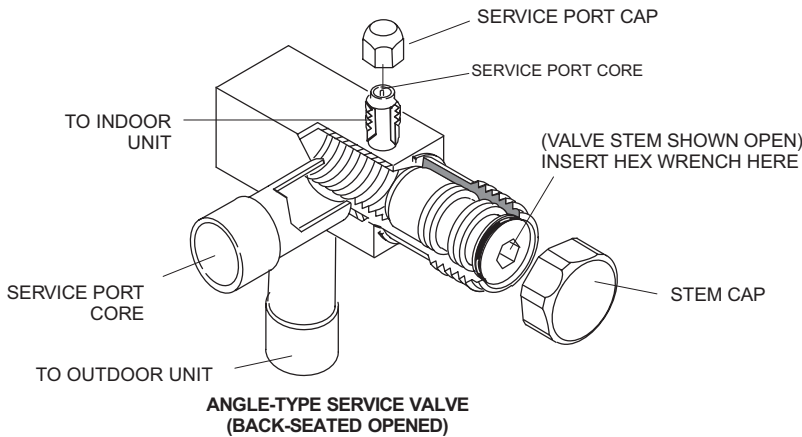

When service valve is **OPEN**, the service port is open to line set, indoor and outdoor unit.

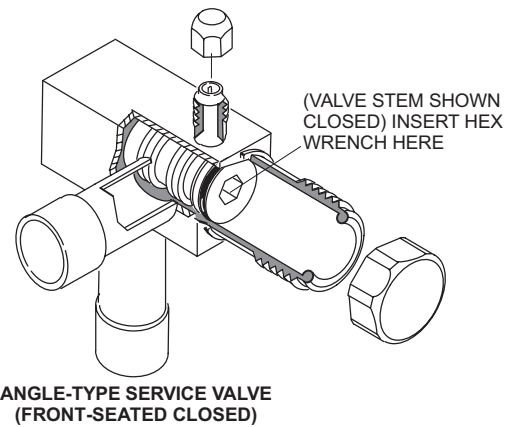

WHEN SERVICE VALVE IS **CLOSED**, THE SERVICE PORT IS OPEN TO THE LINE SET AND INDOOR UNIT.

Operating Ball Type Service Valve:

1. Remove stem cap with an appropriately sized wrench.
2. Use an appropriately sized wrench to open. To open valve, rotate stem counterclockwise 90°. To close rotate stem clockwise 90°.

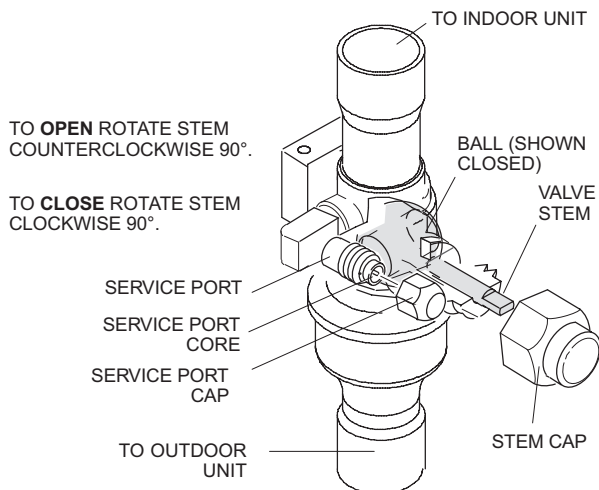

To Access Service Port:

A service port cap protects the service port core from contamination and serves as the primary leak seal.

1. Remove service port cap with an appropriately sized wrench.
2. Connect gauge set to service port.
3. When testing is completed, replace service port cap and tighten as follows:
 - With torque wrench: Finger tighten and torque cap per table 3.
 - Without torque wrench: Finger tighten and use an appropriately sized wrench to turn an additional 1/6 turn clockwise.

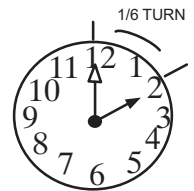

Reinstall Stem Cap:

Stem cap protects the valve stem from damage and serves as the primary seal. Replace the stem cap and tighten as follows:

- With Torque Wrench: Finger tighten and then torque cap per table 3.
- Without Torque Wrench: Finger tighten and use an appropriately sized wrench to turn an additional 1/12 turn clockwise.

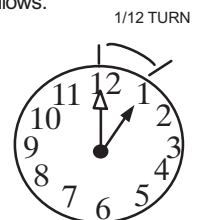

NOTE — A label with specific torque requirements may be affixed to the stem cap. If the label is present, use the specified torque.

FIGURE 2. Angle and Ball Service Valves

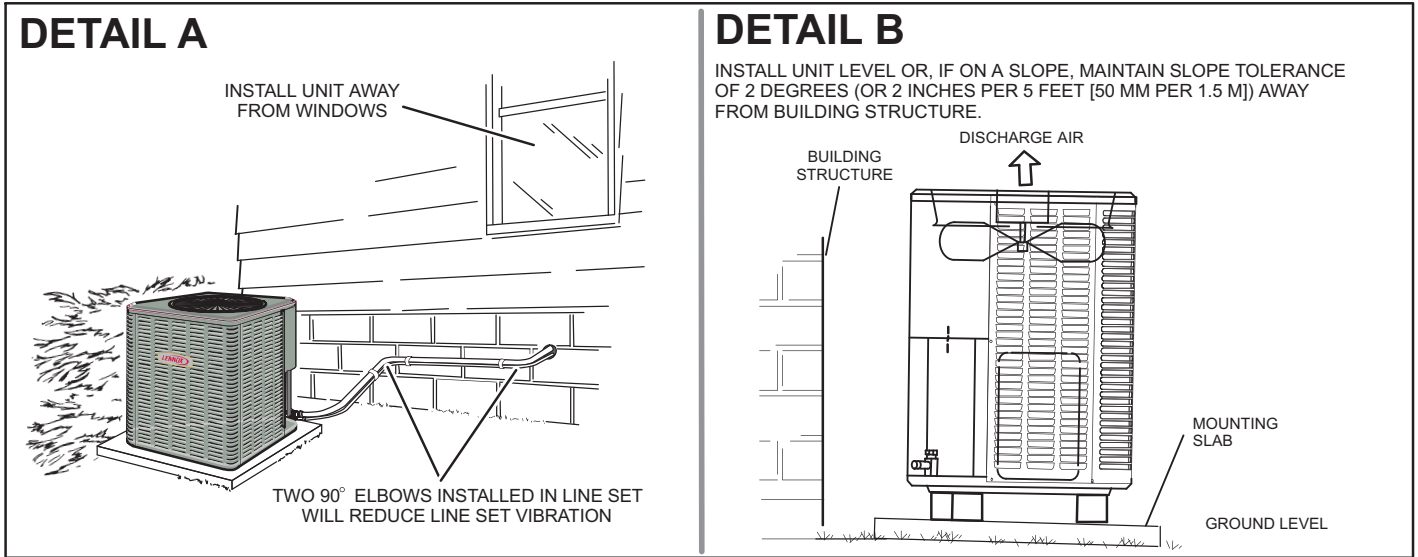

FIGURE 3. Placement and Slab Mounting

Unit Placement

See Unit Dimensions on page 3 for sizing mounting slab, platforms or supports. Refer to page 2 for mandatory installation clearance requirements.

⚠ CAUTION
 In order to avoid injury, take proper precaution when lifting heavy objects..

POSITIONING CONSIDERATIONS

Consider the following when positioning the unit:

- Some localities are adopting sound ordinances based on the unit's sound level registered from the adjacent property, not from the installation property. Install the unit as far as possible from the property line.
- When possible, do not install the unit directly outside a window. Glass has a very high level of sound transmission. For proper placement of unit in relation to a window see the provided illustration in figure 3, detail A.

PLACING UNIT ON SLAB

When installing unit at grade level, the top of the slab should be high enough above grade so that water from higher ground will not collect around the unit. The slab should have a slope tolerance as described in figure 3, detail B.

ROOF MOUNTING

Install the unit a minimum of 6 inches (152 mm) above the roof surface to avoid ice build-up around the unit. Locate the unit above a load bearing wall or area of the roof that can adequately support the unit. Consult local codes for rooftop applications.

If unit coil cannot be mounted away from prevailing winter winds, a wind barrier should be constructed. Size barrier at least the same height and width as outdoor unit. Mount barrier 24 inches (610 mm) from the sides of the unit in the direction of prevailing winds.

⚠ NOTICE
Roof Damage!
 This system contains both refrigerant and oil. Some rubber roofing material may absorb oil, causing the rubber to swell. Bubbles in the rubber roofing material can cause leaks. Protect the roof surface to avoid exposure to refrigerant and oil during service and installation. Failure to follow this notice could result in damage to roof surface.

New or Replacement Line Set

This section provides information on new installation or replacement of existing line set. If a new or replacement line set is not required, then proceed to Brazing Connections on page 11.

If refrigerant lines are routed through a wall, seal and isolate the opening so vibration is not transmitted to the building. Pay close attention to line set isolation during installation of any HVAC system. When properly isolated from building structures (walls, ceilings, floors), the refrigerant lines will not create unnecessary vibration and subsequent sounds.

REFRIGERANT LINE SET

Field refrigerant piping consists of liquid and suction lines from the outdoor unit (braze connections) to the indoor unit coil (flare or braze connections). Use Lennox L15 (braze, non-flare) series line set, or use field-fabricated refrigerant lines as listed in table 2.

TABLE 2. Refrigerant Line Set – in. (mm)

Model	Valve Field Connections		Recommended Line Set		
	Liquid Line	Vapor Line	Liquid Line	Vapor Line	L15 Line Sets
-018					
-024	3/8 in. (10 mm)	3/4 in. (19 mm)	3/8 in. (10 mm)	3/4 in. (19 mm)	L15-41 15 ft. - 50 ft. (4.6 m - 15 m)
-030					
-036					
-042	3/8 in. (10 mm)	7/8 in. (22 mm)	3/8 in. (10 mm)	7/8 in. (22 mm)	L15-65 15 ft. - 50 ft. (4.6 m - 15 m)
-048					
-060	3/8 in. (10 mm)	1-1/8 in. (28 mm)	3/8 in. (10 mm)	1-1/8 in. (28 mm)	Field Fabricated

NOTE - Some applications may require a field-provided 7/8" to 1-1/8" adapter.

NOTE – When installing refrigerant lines longer than 50 feet, contact Lennox Technical Support Product Applications for assistance or Lennox piping manual. To obtain the correct information from Lennox, be sure to communicate the following points:

- Model (EL15XP1) and size of unit (e.g. -060).
- Line set diameters for the unit being installed as listed in table 4 and total length of installation.
- Number of elbows and if there is a rise or drop of the piping.

IMPORTANT

Mineral oils are not compatible with HFC-410A. If oil must be added, it must be a Polyol ester oil.

The compressor is charged with sufficient Polyol ester oil for line set lengths up to 50 feet. Recommend adding oil to system based on the amount of refrigerant charge in the system. No need to add oil in system with 20 pounds of refrigerant or less. For systems over 20 pounds - add one ounce for every five pounds of refrigerant.

Recommended topping-off POE oils are Mobil EAL ARCTIC 22 CC or ICI EMKARATE RL32CF.

MATCHING WITH NEW OR EXISTING INDOOR COIL AND LINE SET

The RFC1-metering line consisted of a small bore copper line that ran from condenser to evaporator coil. Refrigerant was metered into the evaporator by utilizing temperature/pressure evaporation effects on refrigerant in the small RFC line. The length and bore of the RFC line corresponded to the size of cooling unit. If the EL15XP1 is being used with either a new or existing indoor coil which is equipped with a liquid line which served as a metering device (RFCI), the liquid line must be replaced prior to the installation of the EL15XP1 unit. Typically a liquid line used to meter flow is 1/4" in diameter and copper.

LINE SET INSTALLATION AND ISOLATION

IMPORTANT

The Clean Air Act of 1990 bans the intentional venting of refrigerant (CFC's and HCFC's) as of July 1, 1992. Approved methods of recovery, recycling or reclaiming must be followed. Fines and/or incarceration may be levied for non-compliance.

IMPORTANT

If this unit is being matched with an approved line set or indoor unit coil that was previously charged with mineral oil, or if it is being matched with a coil which was manufactured before January of 1999, the coil and line set must be flushed prior to installation. Take care to empty all existing traps. Polyol ester (POE) oils are used in Lennox units charged with HFC-410A refrigerant. Residual mineral oil can act as an insulator, preventing proper heat transfer. It can also clog the expansion device and reduce system performance and capacity.

Failure to properly flush the system, per this instruction and the detailed Installation and Service Procedures manual will void the warranty.

LINE SET

IMPORTANT — Refrigerant lines must not contact structure.

INSTALLATION

Line Set Isolation — The following illustrations are examples of proper refrigerant line set isolation:

REFRIGERANT LINE SET — TRANSITION FROM VERTICAL TO HORIZONTAL

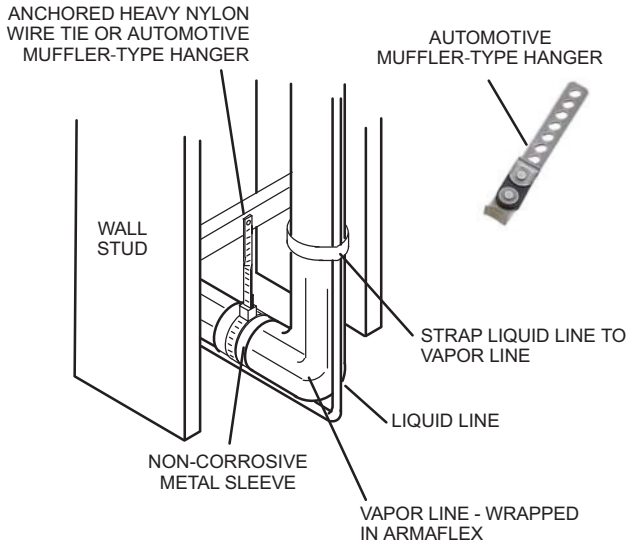

REFRIGERANT LINE SET — INSTALLING HORIZONTAL RUNS

To hang line set from joist or rafter, use either metal strapping material or anchored heavy nylon wire ties.

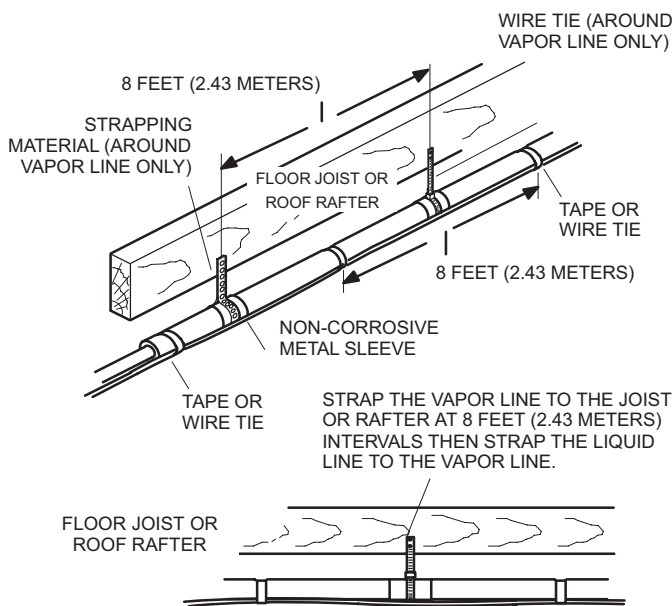

REFRIGERANT LINE SET — INSTALLING VERTICAL RUNS (NEW CONSTRUCTION SHOWN)

NOTE — Insulate liquid line when it is routed through areas where the surrounding ambient temperature could become higher than the temperature of the liquid line or when pressure drop is equal to or greater than 20 psig.

IMPORTANT — Refrigerant lines must not contact wall

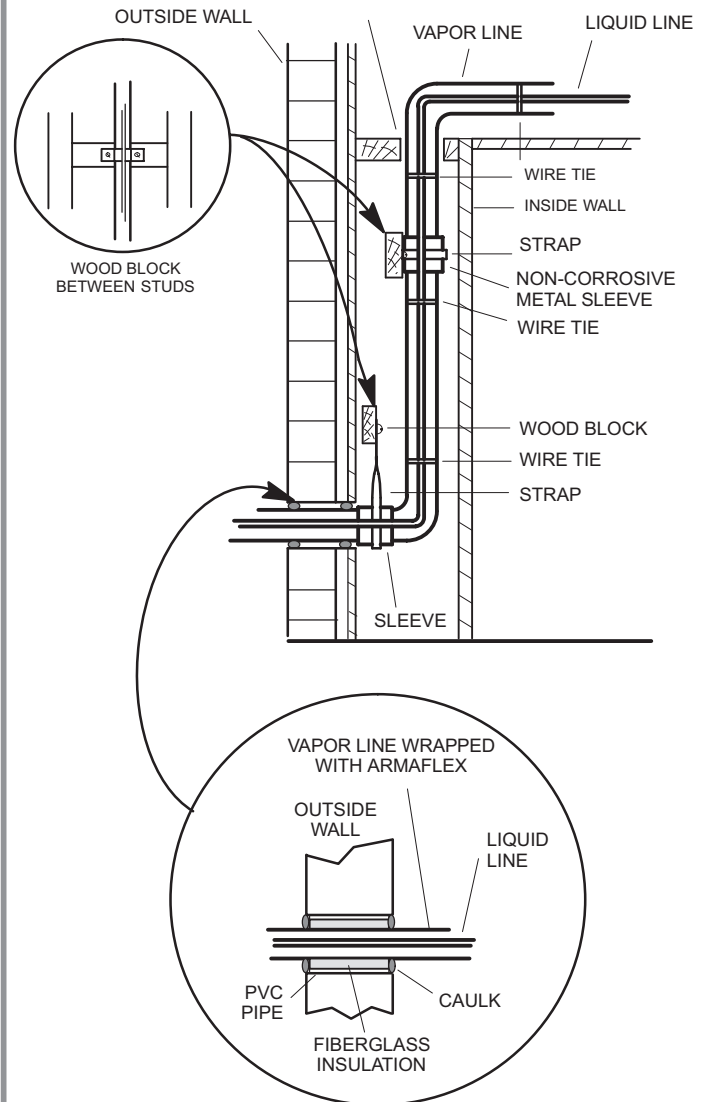

NOTE — Similar installation practices should be used if line set is to be installed on exterior of outside wall.

WARNING — Polyol ester (POE) oils used with HFC-410A refrigerant absorb moisture very quickly. It is very important that the refrigerant system be kept closed as much as possible. **DO NOT** remove line set caps or service valve stub caps until you are ready to make connections.

FIGURE 4. Line Set Installation

Brazing Connections

Use the procedures outlined in figures 5 and 6 for brazing line set connections to service valves.

WARNING



Danger of fire. Bleeding the refrigerant charge from only the high side may result in pressurization of the low side shell and suction tubing. Application of a brazing torch to a pressurized system may result in ignition of the refrigerant and oil mixture. Check the high and low pressures before applying heat.

WARNING



When using a high pressure gas such as nitrogen to pressurize a refrigeration or air conditioning system, use a regulator that can control the pressure down to 1 or 2 psig (6.9 to 13.8 kPa).

CAUTION

Brazing alloys and flux contain materials which are hazardous to your health.

Avoid breathing vapors or fumes from brazing operations. Perform operations only in well-ventilated areas.

Wear gloves and protective goggles or face shield to protect against burns.

Wash hands with soap and water after handling brazing alloys and flux.

IMPORTANT

Allow braze joint to cool before removing the wet rag from the service valve. Temperatures above 250°F can damage valve seals.

IMPORTANT

Use silver alloy brazing rods with 5% minimum silver alloy for copper-to-copper brazing. Use 45% minimum alloy for copper-to-brass and copper-to-steel brazing.

WARNING



Fire, Explosion and Personal Safety hazard. Failure to follow this warning could result in damage, personal injury or death.

Never use oxygen to pressurize or purge refrigeration lines. Oxygen, when exposed to a spark or open flame, can cause fire and/or an explosion, that could result in property damage, personal injury or death.

1 CUT AND DEBUR

Cut ends of the refrigerant lines square (free from nicks or dents) and debur the ends. The pipe must remain round. Do not crimp end of the line.

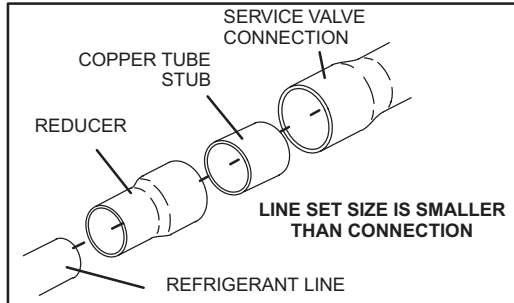
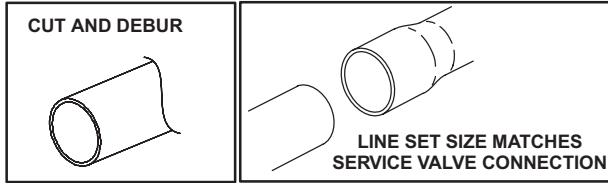

DO NOT CRIMP SERVICE VALVE CONNECTOR WHEN PIPE IS SMALLER THAN CONNECTION

2 CAP AND CORE REMOVAL

Remove service cap and core from both the suction / vapor and liquid line service ports.

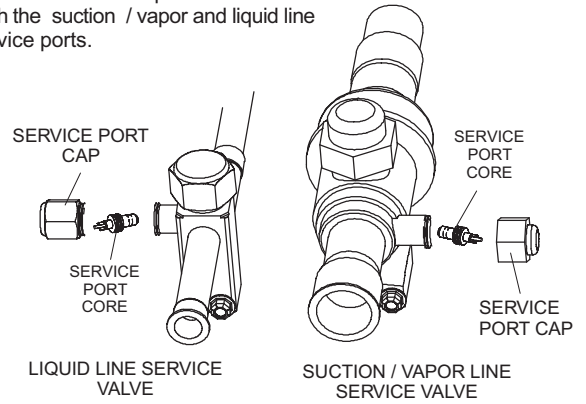

3 ATTACH THE MANIFOLD GAUGE SET FOR BRAZING LIQUID AND SUCTION / VAPOR LINE SERVICE VALVES

Flow regulated nitrogen (at 1 to 2 psig) through the low-side refrigeration gauge set into the liquid line service port valve, and out of the suction / vapor line service port valve.

- A Connect gauge set low pressure side to liquid line service valve (service port).
- B Connect gauge set center port to bottle of nitrogen with regulator.
- C Remove core from valve in suction / vapor line service port to allow nitrogen to escape.

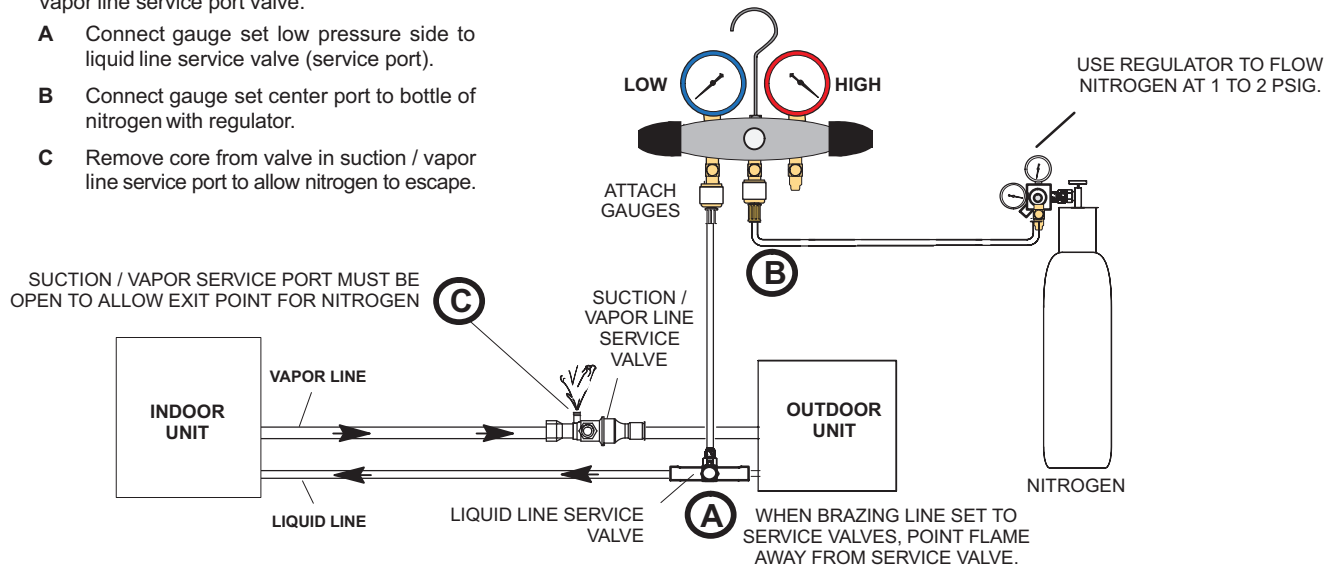

FIGURE 5. Brazing Procedures

4 WRAP SERVICE VALVES

To help protect service valve seals during brazing, wrap water saturated cloths around service valve bodies and copper tube stubs. Use additional water saturated cloths underneath the valve body to protect the base paint.

5 FLOW NITROGEN

Flow regulated nitrogen (at 1 to 2 psig) through the refrigeration gauge set into the valve stem port connection on the liquid service valve and out of the suction / vapor valve stem port. See steps **3A**, **3B** and **3C** on manifold gauge set connections

6 BRAZE LINE SET

Wrap both service valves with water saturated cloths as illustrated here and as mentioned in step 4, before brazing to line set. Water saturated cloths must remain water saturated throughout the brazing and cool-down process.

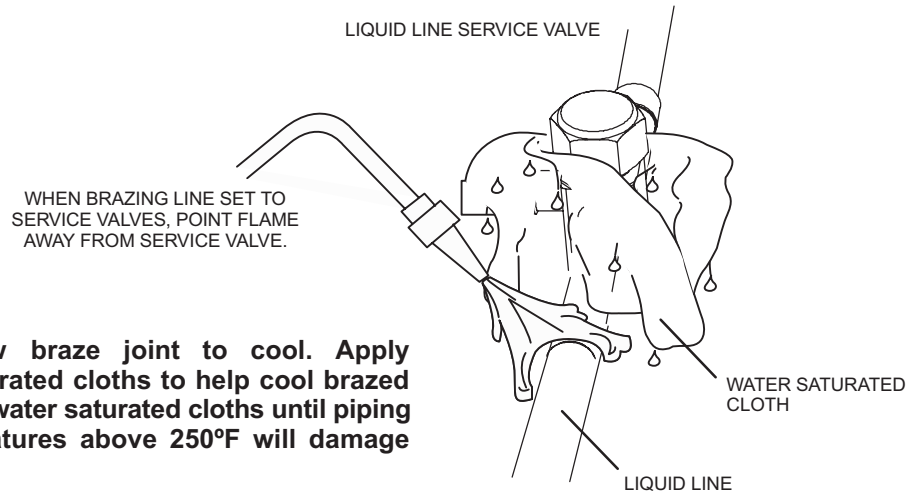

IMPORTANT — Allow braze joint to cool. Apply additional water saturated cloths to help cool braze joint. Do not remove water saturated cloths until piping has cooled. Temperatures above 250°F will damage valve seals.

WARNING

- 1. FIRE, PERSONAL INJURY, OR PROPERTY DAMAGE** may result if you do not wrap a water saturated cloth around both liquid and suction line service valve bodies and copper tube stub while brazing in the line set! The braze, when complete, must be quenched with water to absorb any residual heat.
- 2. Do not open service valves** until refrigerant lines and indoor coil have been leak-tested and evacuated. Refer to procedures provided in this supplement.

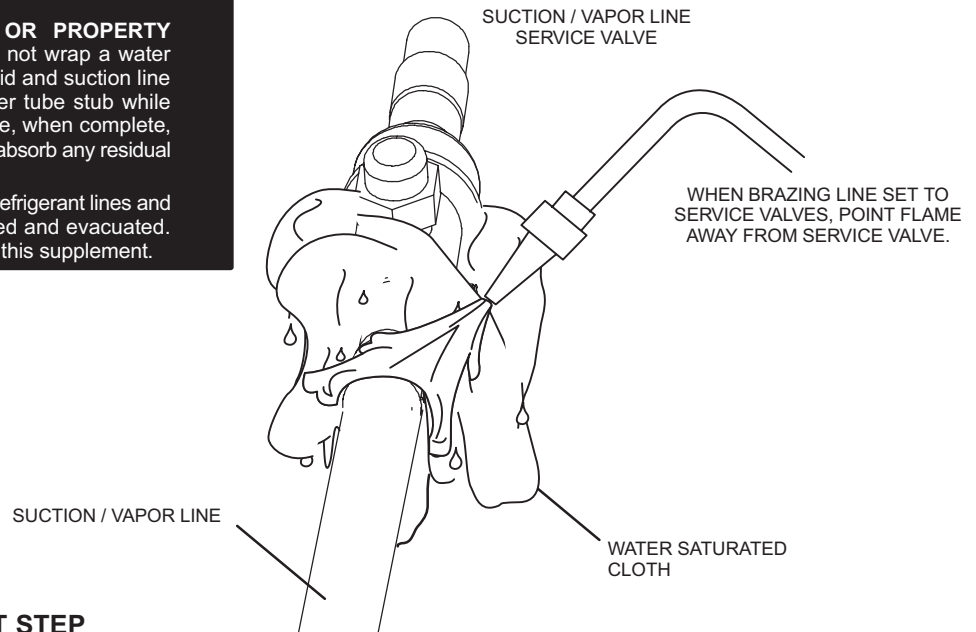

7 PREPARATION FOR NEXT STEP

After all connections have been brazed, disconnect manifold gauge set from service ports. Apply additional water saturated cloths to both services valves to cool piping. Once piping is cool, remove all water saturated cloths. Refer to the unit installation instructions for the next step in preparing the unit.

FIGURE 6. Brazing Procedures (continued)

Flushing Line Set and Indoor Coil

1A TYPICAL EXISTING FIXED ORIFICE REMOVAL PROCEDURE (UNCASED OR COIL SHOWN)

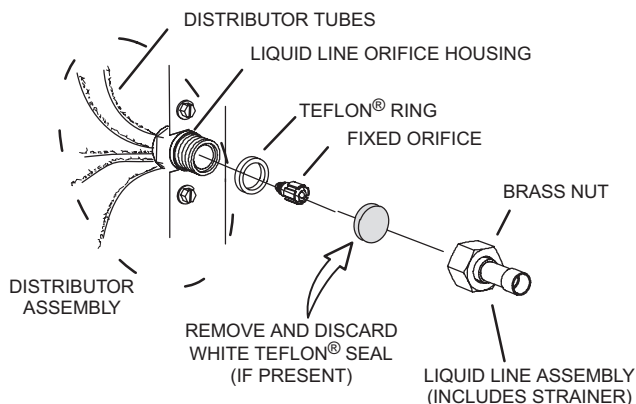

- A On fully cased coils, remove the coil access and plumbing panels.
- B Remove any shipping clamps holding the liquid line and distributor assembly.
- C Using two wrenches, disconnect liquid line from liquid line orifice housing. Take care not to twist or damage distributor tubes during this process.
- D Remove and discard fixed orifice, valve stem assembly if present and Teflon® washer as illustrated above.
- E Use a field-provided fitting to temporarily reconnect the liquid line to the indoor unit's liquid line orifice housing.

1B TYPICAL EXISTING EXPANSION VALVE REMOVAL PROCEDURE (UNCASED COIL SHOWN)

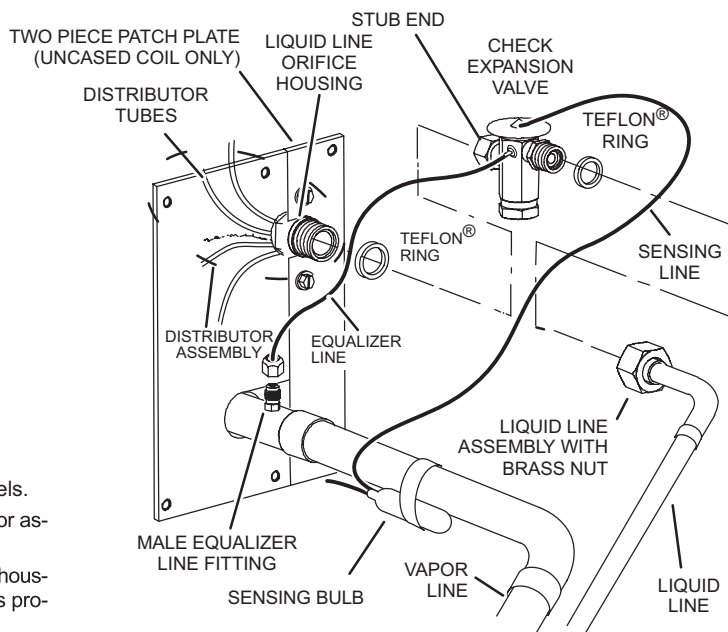

- A On fully cased coils, remove the coil access and plumbing panels.
- B Remove any shipping clamps holding the liquid line and distributor assembly.
- C Disconnect the equalizer line from the check expansion valve equalizer line fitting on the vapor line.
- D Remove the vapor line sensing bulb.
- E Disconnect the liquid line from the check expansion valve at the liquid line assembly.
- F Disconnect the check expansion valve from the liquid line orifice housing. Take care not to twist or damage distributor tubes during this process.
- G Remove and discard check expansion valve and the two Teflon® rings.
- H Use a field-provided fitting to temporary reconnect the liquid line to the indoor unit's liquid line orifice housing.

2 CONNECT GAUGES AND EQUIPMENT FOR FLUSHING PROCEDURE

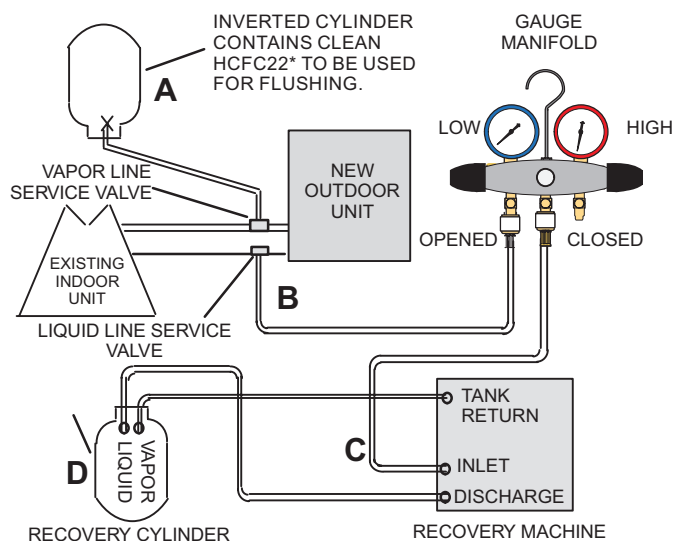

- A Inverted HCFC-22 cylinder with clean refrigerant* to the vapor service valve.
- B HCFC-22 gauge set (low side) to the liquid line valve.
- C HCFC-22 gauge set center port to inlet on the recovery machine with an empty recovery tank to the gauge set.
- D Connect recovery tank to recovery machines per machine instructions.

***IMPORTANT - Clean refrigerant is any refrigerant in a system that has not had compressor burn out. If the system has experienced burn out, it is recommended that the existing line set and indoor coil be replaced.**

3 FLUSHING LINE SET

The line set and indoor unit coil must be flushed with at least the same amount of clean refrigerant* that previously charged the system. Check the charge in the flushing cylinder before proceeding.

- A Set the recovery machine for liquid recovery and start the recovery machine. Open the gauge set valves to allow the recovery machine to pull a vacuum on the existing system line set and indoor unit coil.
- B Invert the cylinder of clean HCFC-22* and open its valve to allow liquid refrigerant to flow into the system through the vapor line valve. Allow the refrigerant to pass from the cylinder and through the line set and the indoor unit coil before it enters the recovery machine.
- C After all of the liquid refrigerant has been recovered, switch the recovery machine to vapor recovery so that all of the HCFC-22 vapor is recovered. Allow the recovery machine to pull the system down to 0.
- D Close the valve on the inverted HCFC-22 drum and the gauge set valves. Pump the remaining refrigerant out of the recovery machine and turn the machine off.

FIGURE 7. Removing Metering Device and Flushing

Installing Indoor Metering Device

This outdoor unit is designed for use in systems that use a check expansion valve metering device at the indoor coil. See the Lennox EL15XP1 Product Specification bulletin for approved expansion valve kit match-ups. The expansion valve unit can be installed internal or external to the indoor coil.

In applications where an uncased coil is being installed in a field-provided plenum, install the expansion valve in a manner that will provide access for field servicing of the expansion valve. Refer to below illustration for reference during installation of expansion valve unit.

INDOOR EXPANSION VALVE INSTALLATION

(Uncased Coil Shown)

Labels in diagram: TWO PIECE PATCH PLATE (UNCASED COIL ONLY), DISTRIBUTOR TUBES, LIQUID LINE ORIFICE HOUSING, STUB END, EXPANSION VALVE, TEFLON® RING, SENSING LINE, EQUALIZER LINE, LIQUID LINE ASSEMBLY WITH BRASS NUT, VAPOR LINE, LIQUID LINE, MALE EQUALIZER LINE FITTING (SEE EQUALIZER LINE INSTALLATION FOR FURTHER DETAILS).

Sensing bulb insulation is required if mounted external to the coil casing. sensing bulb installation for bulb positioning.

- A** Remove the field-provided fitting that temporary reconnected the liquid line to the indoor unit's distributor assembly.
- B** Install one of the provided Teflon® rings around the stubbed end of the expansion valve and lightly lubricate the connector threads and expose surface of the Teflon® ring with refrigerant oil.
- C** Attach the stubbed end of the expansion valve to the liquid line orifice housing. Finger tighten and use an appropriately sized wrench to turn an additional 1/2 turn clockwise as illustrated in the figure above, or 20 ft-lb.
- D** Place the remaining Teflon® washer around the other end of the expansion valve. Lightly lubricate connector threads and expose surface of the Teflon® ring with refrigerant oil.
- E** Attach the liquid line assembly to the expansion valve. Finger tighten and use an appropriately sized wrench to turn an additional 1/2 turn clockwise as illustrated in the figure above or 20 ft-lb.

1/2 Turn

EQUALIZER LINE INSTALLATION

- A** Remove and discard either the flare seal cap or flare nut with copper flare seal bonnet from the equalizer line port on the vapor line as illustrated in the figure to the right.
- B** Remove and discard either the flare seal cap or flare nut with copper flare seal bonnet from the equalizer line port on the vapor line as illustrated in the figure to the right.

Labels: FLARE SEAL CAP, FLARE NUT, COPPER FLARE SEAL BONNET, MALE BRASS EQUALIZER LINE FITTING, VAPOR LINE.

SENSING BULB INSTALLATION

- A** Attach the vapor line sensing bulb in the proper orientation as illustrated to the right using the clamp and screws provided.

NOTE — Confirm proper thermal contact between vapor line and expansion bulb before insulating the sensing bulb once installed.

- B** Connect the equalizer line from the expansion valve to the equalizer vapor port on the vapor line. Finger tighten the flare nut plus 1/8 turn (7 ft-lbs) as illustrated below.

Labels: VAPOR LINE, BULB.

ON LINES SMALLER THAN 7/8", MOUNT SENSING BULB AT EITHER THE 3 OR 9 O'CLOCK POSITION.

ON 7/8" AND LARGER LINES, MOUNT SENSING BULB AT EITHER THE 4 OR 8 O'CLOCK POSITION. NEVER MOUNT ON BOTTOM OF LINE.

NOTE — NEVER MOUNT ON BOTTOM OF LINE.

1/8 Turn

FIGURE 8. Installing Indoor Expansion Valve

Leak Test Line Set and Indoor Coil

⚠ WARNING



When using a high pressure gas such as nitrogen to pressurize a refrigeration or air conditioning system, use a regulator that can control the pressure down to 1 or 2 psig (6.9 to 13.8 kPa).

⚠ IMPORTANT

Leak detector must be capable of sensing HFC refrigerant.

⚠ WARNING

Refrigerant can be harmful if it is inhaled. Refrigerant must be used and recovered responsibly.

Failure to follow this warning may result in personal injury or death.

1 CONNECT GAUGE SET

- A** Connect an HFC-410A manifold gauge set high pressure hose to the vapor valve service port.

NOTE — Normally, the high pressure hose is connected to the liquid line port. However, connecting it to the vapor port better protects the manifold gauge set from high pressure damage.

- B** With both manifold valves closed, connect the cylinder of HFC-410A refrigerant to the center port of the manifold gauge set.

NOTE — Later in the procedure, the HFC-410A container will be replaced by the nitrogen container.

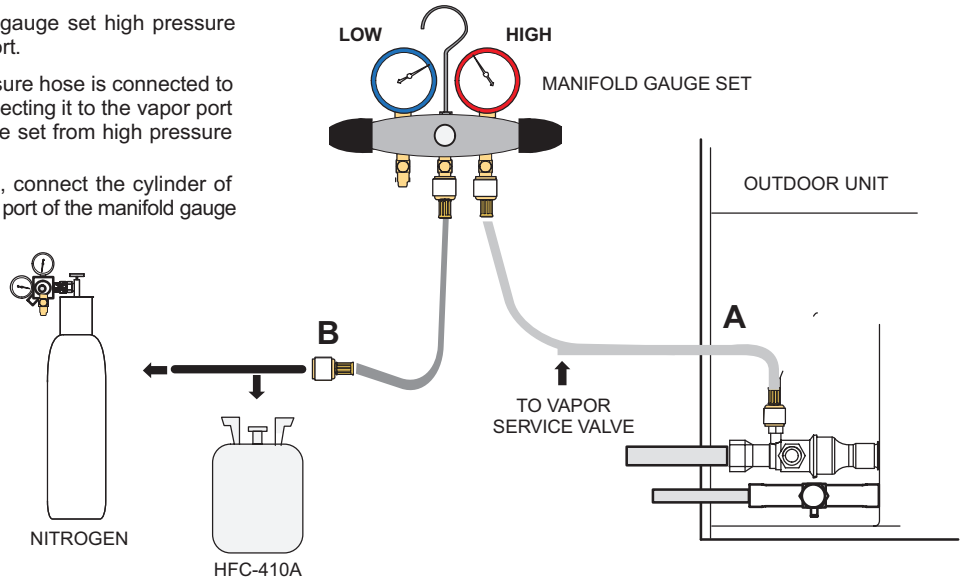

2 TEST FOR LEAKS

After the line set has been connected to the indoor and outdoor units, check the line set connections and indoor unit for leaks. Use the following procedure to test for leaks:

- With both manifold valves closed, connect the cylinder of HFC-410A refrigerant to the center port of the manifold gauge set. Open the valve on the HFC-410A cylinder (vapor only).
- Open the high pressure side of the manifold to allow HFC-410A into the line set and indoor unit. Weigh in a trace amount of HFC-410A. [A trace amount is a maximum of two ounces (57 g) refrigerant or three pounds (31 kPa) pressure]. Close the valve on the HFC-410A cylinder and the valve on the high pressure side of the manifold gauge set. Disconnect the HFC-410A cylinder.
- Connect a cylinder of dry nitrogen with a pressure regulating valve to the center port of the manifold gauge set.
- Adjust dry nitrogen pressure to 150 psig (1034 kPa). Open the valve on the high side of the manifold gauge set in order to pressurize the line set and the indoor unit.
- After a few minutes, open one of the service valve ports and verify that the refrigerant added to the system earlier is measurable with a leak detector.
- After leak testing disconnect gauges from service ports.

FIGURE 9. Leak Test

Evacuating Line Set and Indoor Coil

1 CONNECT GAUGE SET

NOTE — Remove cores from service valves (if not already done).

- A** Connect low side of manifold gauge set with 1/4 SAE in-line tee to vapor line service valve
- B** Connect high side of manifold gauge set to liquid line service valve
- C** Connect micron gauge available connector on the 1/4 SAE in-line tee.
- D** Connect the vacuum pump (with vacuum gauge) to the center port of the manifold gauge set. The center port line will be used later for both the HFC-410A and nitrogen containers.

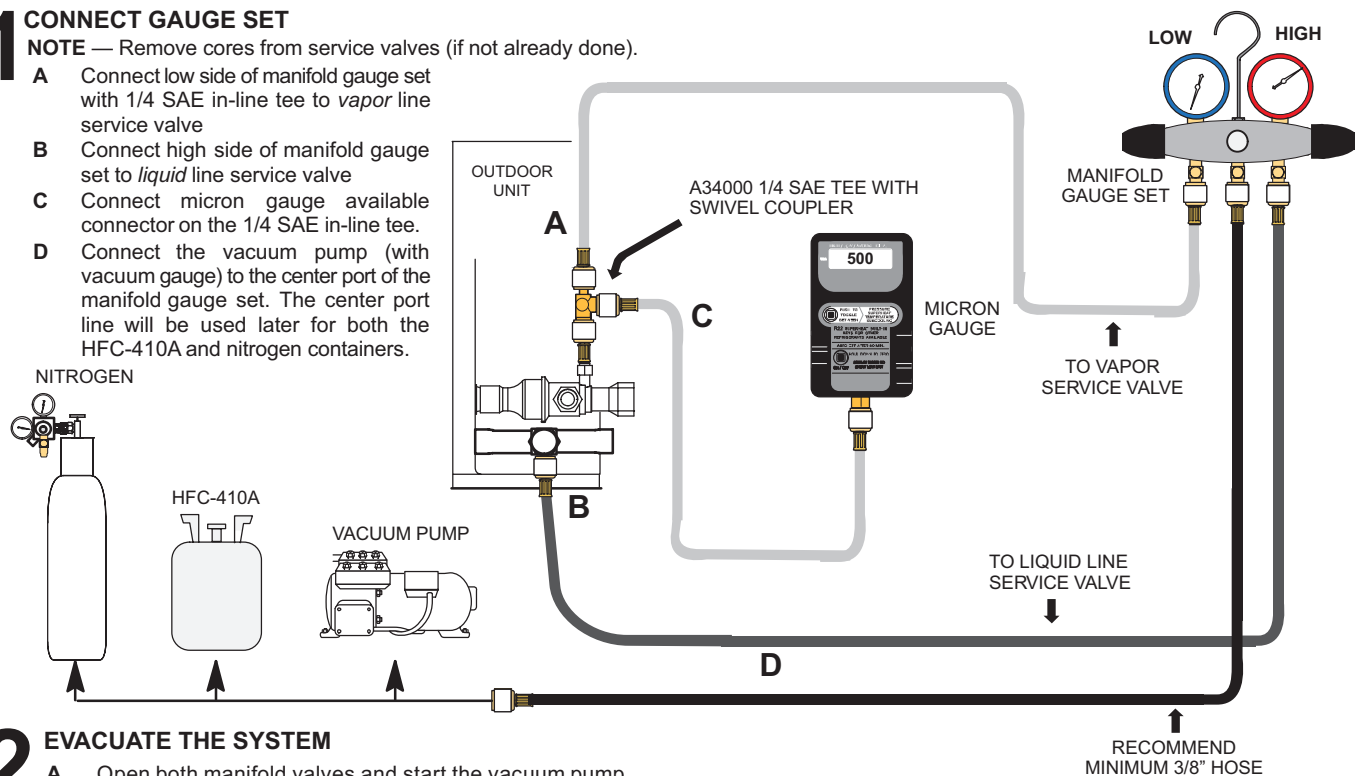

2 EVACUATE THE SYSTEM

- A** Open both manifold valves and start the vacuum pump.
- B** Evacuate the line set and indoor unit to an **absolute pressure** of 23,000 microns (29.01 inches of mercury).
 - NOTE** — During the early stages of evacuation, it is desirable to close the manifold gauge valve at least once. A rapid rise in pressure indicates a relatively large leak. If this occurs, **repeat the leak testing procedure**.
 - NOTE** — The term **absolute pressure** means the total actual pressure within a given volume or system, above the absolute zero of pressure. Absolute pressure in a vacuum is equal to atmospheric pressure minus vacuum pressure.
- C** When the absolute pressure reaches 23,000 microns (29.01 inches of mercury), perform the following:
 - Close manifold gauge valves
 - Close valve on vacuum pump
 - Turn off vacuum pump
 - Disconnect manifold gauge center port hose from vacuum pump
 - Attach manifold center port hose to a dry nitrogen cylinder with pressure regulator set to 150 psig (1034 kPa) and purge the hose.
 - Open manifold gauge valves to break the vacuum in the line set and indoor unit.
 - Close manifold gauge valves.
- D** Shut off the dry nitrogen cylinder and remove the manifold gauge hose from the cylinder. Open the manifold gauge valves to release the dry nitrogen from the line set and indoor unit.
- E** Reconnect the manifold gauge to the vacuum pump, turn the pump on, and continue to evacuate the line set and indoor unit until the absolute pressure does not rise above 500 microns (29.9 inches of mercury) within a 20-minute period after shutting off the vacuum pump and closing the manifold gauge valves.
- F** When the absolute pressure requirement above has been met, disconnect the manifold hose from the vacuum pump and connect it to an upright cylinder of HFC-410A refrigerant. Open the manifold gauge valve 1 to 2 psig in order to release the vacuum in the line set and indoor unit.
- G** Perform the following:
 - Close manifold gauge valves.
 - Shut off HFC-410A cylinder.
 - Reinstall service valve cores by removing manifold hose from service valve. Quickly install cores with core tool while maintaining a positive system pressure.
 - Replace stem caps and secure finger tight, then tighten an additional one-sixth (1/6) of a turn as illustrated.

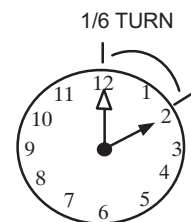

FIGURE 10. Evacuating the System

⚠ IMPORTANT

Use a thermocouple or thermistor electronic vacuum gauge that is calibrated in microns. Use an instrument capable of accurately measuring down to 50 microns.

⚠ WARNING

Possible equipment damage.

Avoid deep vacuum operation. Do not use compressors to evacuate a system. Extremely low vacuum can cause internal arcing and compressor failure. Damage caused by deep vacuum operation will void warranty.

Evacuating the system of non-condensables is critical for proper operation of the unit. Non-condensables are defined as any gas that will not condense under temperatures and pressures present during operation of an air conditioning system. Non-condensables and water suction combine with refrigerant to produce substances that corrode copper piping and compressor parts.

Electrical

In the U.S.A., wiring must conform with current local codes and the current National Electric Code (NEC). In Canada, wiring must conform with current local codes and the current Canadian Electrical Code (CEC).

Refer to the furnace or air handler installation instructions for additional wiring application diagrams and refer to unit nameplate for minimum circuit ampacity and maximum overcurrent protection size.

24VAC TRANSFORMER

Use the transformer provided with the furnace or air handler for low-voltage control power (24VAC - 40 VA minimum).

⚠ WARNING



Electric Shock Hazard. Can cause injury or death. Unit must be properly grounded in accordance with national and local codes.

Line voltage is present at all components when unit is not in operation on units with single-pole contactors. Disconnect all remote electric power supplies before opening access panel. Unit may have multiple power supplies.

SIZE CIRCUIT AND INSTALL SERVICE DISCONNECT SWITCH

Refer to the unit nameplate for minimum circuit ampacity, and maximum fuse or circuit breaker (HACR per NEC). Install power wiring and properly sized disconnect switch.

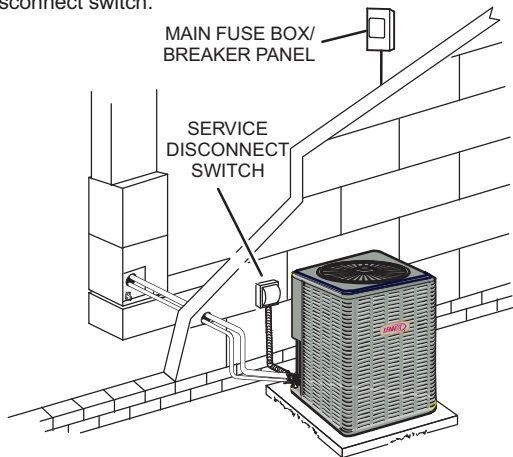

NOTE — Units are approved for use only with copper conductors. Ground unit at disconnect switch or to an earth ground.

INSTALL THERMOSTAT

Install room thermostat (ordered separately) on an inside wall approximately in the center of the conditioned area and 5 feet (1.5m) from the floor. It should not be installed on an outside wall or where it can be affected by sunlight or drafts.

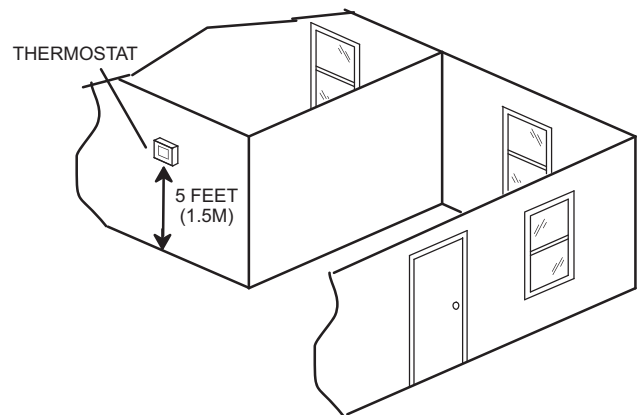

NOTE — 24VAC, Class II circuit connections are made in the control panel.

Typical 24VAC Control Wiring Diagrams (Field Installed)

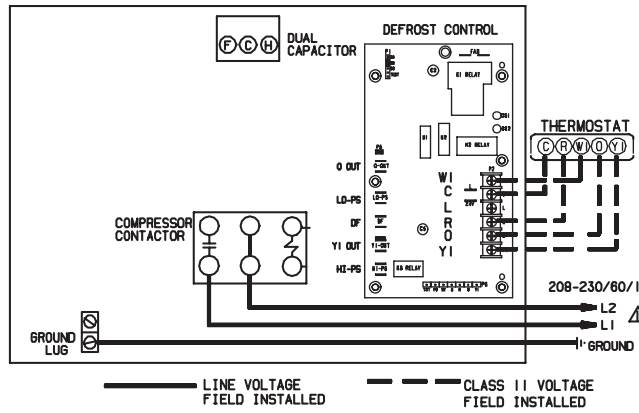
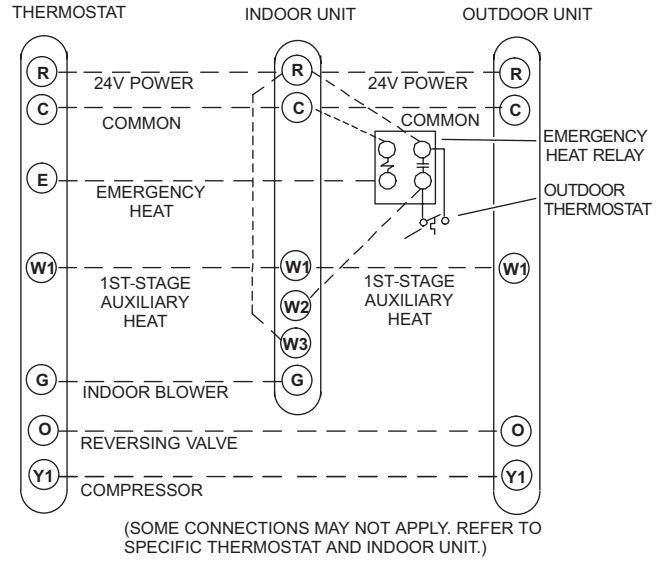
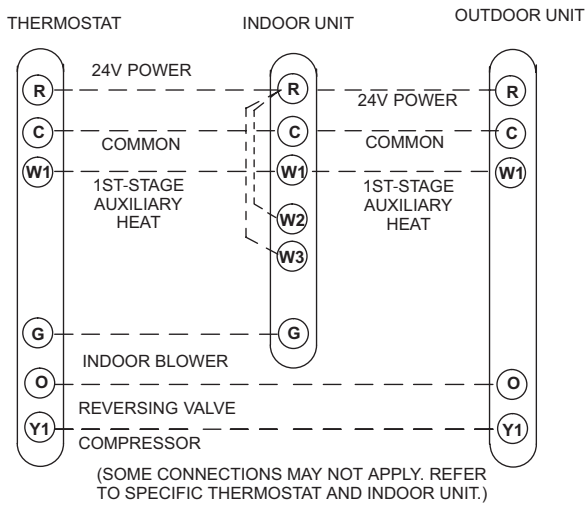

WARNING! - ELECTRIC SHOCK HAZARD. Can cause INJURY or DEATH. Unit must be grounded in accordance with national and local codes.

NOTE - For use with copper conductors only. Refer to unit rating plate for minimum circuit ampacity and maximum over-current protection size.

FIGURE 11. Typical Control Wiring

System Operation

UNIT COMPONENTS

IMPORTANT

Some scroll compressors have an internal vacuum protector that will unload scrolls when suction pressure goes below 20 psig. A hissing sound will be heard when the compressor is running unloaded. Protector will reset when low pressure in system rises above 40 psig. **DO NOT REPLACE COMPRESSOR.**

The outdoor unit and indoor blower cycle on demand from the room thermostat. If the thermostat blower switch is in the **ON** position, the indoor blower operates continuously.

Bi-Flow Liquid line Filter Drier

The unit is equipped with a large-capacity bi-flow filter drier which keeps the system clean and dry. If replacement is necessary, order another of the same design and capacity. The replacement filter drier must be suitable for use with HFC-410A refrigerant.

Low Pressure Switch (S87)

The EL15XP1 is equipped with an auto-reset low pressure switch which is located on the vapor line. The switch shuts off the compressor when the vapor pressure falls below the factory setting. This switch, which is ignored during defrost operation, closes at pressures at or above 40 + 5 psig (276 + 34 kPa) and opens at 25 + 5 psig (172 + 34 kPa). It is not adjustable.

Low Pressure Switch Bypass (S41) (Optional)

For use in applications where the heat pump is operated in outdoor ambient temperatures below 15°F.

- Prevents nuisance trips from the low pressure switch
- Wired in parallel with the low pressure switch

High Pressure Switch (S4)

The EL15XP1 is equipped with an auto-reset high pressure switch (single-pole, single-throw) which is located on the liquid line. The switch shuts off the compressor when discharge pressure rises above the factory setting. The switch is normally closed and is permanently adjusted to trip (open) at 590 + 15 psig (4068 + 103 kPa).

NOTE – A Schrader core is under the pressure switches.

Defrost Thermostat (S6)

The defrost thermostat is located on the liquid line between the check/expansion valve and the distributor. When defrost thermostat senses 42°F (5.5°C) or cooler, the thermostat contacts close and send a signal to the defrost control to start the defrost timing. It also terminates defrost when the liquid line warms up to 70°F (21°C).

Crankcase Heater (HR1) and Thermostat Switch (S40)

All models sizes are equipped with a belly band type crankcase heater. HR1 prevents liquid from accumulating in the compressor. The HR1 is controlled by a single pole, single throw thermostat switch (S40) located on the liquid line. On all units, the heater is on when there is no compressor operation.

Thermal Protection Switch (S173) – Compressor Mounted

Some EL15XP1 units are equipped with a compressor mounted normally closed temperature switch that prevents compressor damage due to overheating caused by internal friction. The switch is located on top of the compressor casing (see figure 1). This switch senses the compressor casing temperature and opens at 239-257°F (115°C-125°C) to shut off compressor operation. The auto-reset switch closes when the compressor casing temperature falls to 151-187°F (66°C-86°C), and the compressor is re-energized. This single-pole, single-throw (SPST) bi-metallic switch is wired in series with the 24V Y input signal to control compressor operation.

System Configuration

Demand Defrost Control (A108)

The demand defrost control measures differential temperatures to detect when the system is performing poorly because of ice build-up on the outdoor coil. The control *self-calibrates* when the defrost system starts and after each system defrost cycle. The demand defrost control components are shown in figure 12.

- Demand defrost control connections, jumpers and LED locations are shown in figure 12.
- Demand defrost control connections, jumpers and LED descriptions are listed on table 3.
- Demand defrost control status, fault and lockout LEDs are listed in table 4.

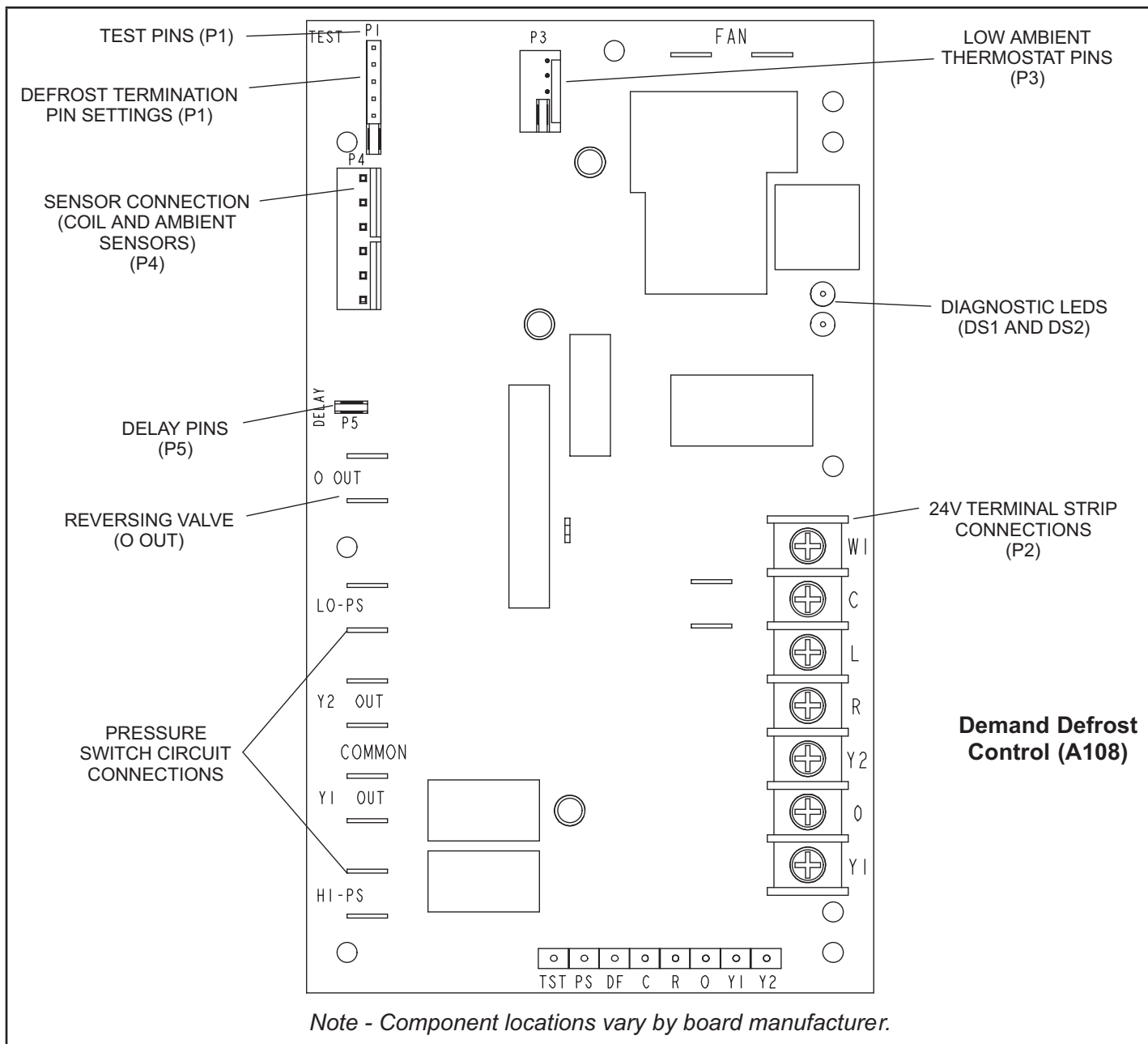

FIGURE 12. Demand Defrost Control (A108)

TABLE 3
DEMAND DEFROST CONTROL (A108) INPUTS, OUTPUTS AND CONFIGURABLE SETTINGS

Control Locations	Control Label or Description	Purpose	Function
P1	50, 70, 90, 100	Defrost Temperature Termination Shunt (Jumper) Pins	The demand defrost control (illustrated in figure 17) has selections which are: 50, 70, 90, and 100°F (10, 21, 32 and 38°C). The shunt termination pin is factory-set at 50°F (10°C). If the temperature shunt is not installed, the default termination temperature is 90°F (32°C).
P2	W1	24VAC Thermostat Input / Output	24VAC input / output from indoor thermostat to indoor unit.
	C	24VAC Common	24VAC common.
	L	Thermostat Service Light	Thermostat service light connection.
	R	24VAC	24VAC.
	Y2	Thermostat Input	Controls the second stage operation of the unit.
	O	Thermostat Input	Reversing valve solenoid.
P3	55, 50, 45, 40	Low Ambient Thermostat Pins	Provides selection of the Y2 compressor lock-in temperature. Valid options are 40, 45, 50 and 55 degrees Fahrenheit.
P4	DIS-YEL	Coil Sensor	(P4-5) Ground connection for outdoor coil temperature sensor. (P4-6) Connection for outdoor coil temperature sensor.
	AMB-BLACK	Ambient Sensor	(P4-3) Ground connection for outdoor ambient temperature sensor. (P4-4) Connection for outdoor ambient temperature sensor.
	COIL-BROWN	Discharge Sensor	<i>No discharge sensor is used; replaced by 10K resistor.</i>
P5	DELAY	Delay Mode	The demand defrost control has a field-selectable function to reduce occasional sounds that may occur while the unit is cycling in and out of the defrost mode. When a jumper is installed on the DELAY pins, the compressor will be cycled off for 30 seconds going in and out of the defrost mode. Units are shipped with jumper installed on DELAY pins. <i>NOTE - The 30-second off cycle is NOT functional when TEST pins on P1 are jumpered.</i>
P6	TST, PS DF, C, R, O, Y1, Y2	Factory Test Connectors	No field use.
DS1	RED LED	Diagnostic LED	Demand defrost control LEDs may be OFF, ON, or FLASHING to indicate diagnostic conditions which are described in table 3.
DS2	GREEN LED		
FAN	TWO CONNECTORS	Condenser Fan Operation	These two connections provide power for the condenser fan.
O OUT	O OUT	24 VAC output	24 VAC output connection for reversing valve.
LO-PS	LO-PS	Low-Pressure Switch	When the low pressure switch trips, the demand defrost control will cycle off the compressor, and the strike counter in the demand defrost control will count one strike. The low pressure switch is ignored under the following conditions: <ul style="list-style-type: none"> ● during the defrost cycle and 90 seconds after the termination of defrost ● when the average ambient sensor temperature is below 0°F (-18°C) ● during 90 seconds following the start of the compressor ● during TEST mode.
Y2 OUT	Y2 OUT	24 VAC Output	24 VAC output for second-stage compressor solenoid.
Y1 OUT	Y1 OUT	24 VAC Common Output	24 VAC common output, switched for enabling compressor contactor.
HS-PS	HS-PS	High-Pressure Switch	When the high pressure switch trips, the demand defrost control will cycle off the compressor, and the strike counter in the demand defrost control will count one strike.
L	L	Service Light Output	24VAC service light output.
24V	24V	24 Volt output	24VAC typically used to supply power to the Lennox System Operation Monitor (LSOM). Not used in this system.

Defrost System

This section addresses:

- Emergency Heat
- Defrost System Overview
- Defrost Control Connections, Jumper Settings and Features
- Operational Mode Overview (Calibration, Normal and Defrost)
- Defrost Cycle Actuation

EMERGENCY HEAT (AMBER LIGHT)

An emergency heat function is designed into some room thermostats. This feature is applicable when isolation of the outdoor unit is required, or when auxiliary electric heat is staged by outdoor thermostats. When the room thermostat is placed in the emergency heat position, the outdoor unit control circuit is isolated from power and field-provided relays bypass the outdoor thermostats. An amber indicating light simultaneously comes on to remind the homeowner that he is operating in the emergency heat mode.

Emergency heat is usually used during an outdoor unit shutdown, but it should also be used following a power outage if power has been off for over an hour and the outdoor temperature is below 50°F (10°C). System should be left in the emergency heat mode at least six hours to allow the crankcase heater sufficient time to prevent compressor slugging.

DEFROST SYSTEM OVERVIEW

The control monitors ambient temperature, outdoor coil temperature, and total run time to determine when a defrost cycle is required. The coil temperature probe is designed with a spring clip to allow mounting to the outside coil tubing. The location of the coil sensor is important for proper defrost operation.

NOTE – The demand defrost control accurately measures the performance of the system as frost accumulates on the outdoor coil. This typically will translate into longer running time between defrost cycles as more frost accumulates on the outdoor coil before the demand defrost control initiates defrost cycles.

DEFROST CONTROL CONNECTIONS, JUMPERS SETTINGS AND FEATURES

Defrost Temperature Termination Jumper Settings (P1)

The demand defrost control selections are: 50, 70, 90 and 100°F (10, 21, 32 and 38°C). The shunt termination pin is factory set at 50°F (10°C). If temperature shunt is not installed, default termination temperature is 90°F (32°C).

Test Pins (P1) Function

Placing the jumper on the field test pins (P1) allows the technician to:

- Clear short cycle lockout
- Clear five-strike fault lockout
- Cycle the unit in and out of defrost mode

Place the unit in defrost mode to clear the coil

Compressor Delay Mode (P5)

The demand defrost control has a field-selectable function to reduce occasional sounds that may occur while the unit is cycling in and out of the defrost mode. When a jumper is installed on the **DELAY** pins, the compressor will be cycled off for 30 seconds going in and out of the defrost mode. Units are shipped with jumper installed on **DELAY** pins.

NOTE - The 30 second off cycle is NOT functional when jumpering the TEST pins.

DEMAND DEFROST CONTROL (A108) DIAGNOSTIC LEDS

The state (Off, On, Flashing) of two LEDs on the demand defrost control (DS1 [Red] and DS2 [Green]) indicate diagnostics conditions that are described in table 4.

**TABLE 4
DEMAND DEFROST CONTROL (A108) DIAGNOSTIC LEDS**

DS1 and DS2 System Status, Fault and Lockout Codes					
DS2 Green	DS1 Red	Type	Condition/Code	Possible Cause(s)	Solution
OFF	OFF	Status	Power problem	No power (24V) to demand defrost control terminals R and C or demand defrost control failure.	1. Check control transformer power (24V). 2. If power is available to demand defrost control and LED(s) do not light, replace demand defrost control.
Simultaneous SLOW Flash		Status	Normal operation	Unit operating normally or in standby mode.	None required.
Alternating SLOW Flash		Status	5-minute anti-short cycle delay	Initial power up, safety trip, end of room thermostat demand.	None required (jumper TEST pins to override)
Simultaneous FAST Flash		Fault	Ambient Sensor Problem	Sensor being detected open or shorted or out of temperature range. Demand defrost control will revert to time/temperature defrost operation. (System will still heat or cool).	
Alternating FAST Flash		Fault	Coil Sensor Problem	Sensor being detected open or shorted or out of temperature range. Demand defrost control will not perform demand or time/temperature defrost operation. (System will still heat or cool.)	
ON	ON	Fault	Demand Defrost Control Failure	Indicates that demand defrost control has internal component failure. Cycle 24VAC power to demand defrost control. If code does not clear, replace demand defrost control.	
OFF	SLOW Flash	Fault	Low Pressure Fault	<ul style="list-style-type: none"> Restricted air flow over indoor or outdoor coil. Improper refrigerant charge in system. Improper metering device installed or incorrect operation of metering device. Incorrect or improper sensor location or connection to system. 	<ul style="list-style-type: none"> Remove any blockages or restrictions from coils and/or fans. Check indoor and outdoor fan motor for proper current draws. Check system charge using subcooling method. Check system operating pressures and compare to unit subcooling tables in this instruction or located on unit access panel. Make sure all pressure switches and sensors have secure connections to system to prevent refrigerant leaks or errors in pressure and temperature measurements.
OFF	ON	Lockout	Low Pressure Lockout		
SLOW Flash	OFF	Fault	High Pressure Fault		
ON	OFF	Lockout	High Pressure Lockout		
SLOW Flash	ON	Fault	Discharge Line Temperature Fault	This code detects shorted sensor or high discharge temperatures. If the discharge line temperature exceeds a temperature of 285°F (140°C) during compressor operation, the demand defrost control will de-energize the compressor contactor output (and the defrost output if active). The compressor will remain off until the discharge temperature has dropped below 225°F (107°C).	
FAST Flash	ON	Lockout	Discharge Line Temperature Lockout		
OFF	Fast Flash	Fault	Discharge Sensor Fault	The demand defrost control detects open sensor or out of temperature sensor range. This fault is detected by allowing the unit to run for 90 seconds before checking sensor resistance. If the sensor resistance is not within range after 90 seconds, the demand defrost control will count one fault. After 5 faults, the demand defrost control will lock out.	
Fast Flash	OFF	Lockout	Discharge Sensor Lockout		
(Each fault adds 1 strike to that code's counter; 5 strikes per code = LOCKOUT)					

Field Operation Checklist for Two-Stage Modulation Compressors			
Unit Readings	Y1 - First-Stage	Expected results during Y2 demand (Toggle switch On)	Y2 - Second-Stage
Compressor			
Voltage		Same	
Amperage		Higher	
Outdoor Unit Fan Motor			
Amperage		Same or Higher	
Temperature			
Ambient		Same	
Outdoor Coil Discharge Air		Higher	
Compressor Discharge Line		Higher	
Indoor Return Air		Same	
Indoor Coil Discharge Air		Lower	
Pressures			
Suction (Vapor)		Lower	
Liquid		Higher	

⚠ IMPORTANT

After testing has been completed, properly reposition test jumper across desired timing pins

Maintenance

DEALER

⚠ WARNING



Electric Shock Hazard. Can cause injury or death. Unit must be properly grounded in accordance with national and local codes.

Line voltage is present at all components when unit is not in operation on units with single-pole contactors. Disconnect all remote electric power supplies before opening access panel. Unit may have multiple power supplies.

⚠ WARNING

Improper installation, adjustment, alteration, service or maintenance can cause property damage, personal injury or loss of life. Installation and service must be performed by a licensed professional HVAC installer or equivalent, service agency, or the gas supplier.

NOTICE !

Failure to follow instructions will cause damage to the unit.

This unit is equipped with an aluminum coil. Aluminum coils may be damaged by exposure to solutions with a pH below 5 or above 9. The aluminum coil should be cleaned using potable water at a moderate pressure (less than 50psi). If the coil cannot be cleaned using water alone, Lennox recommends use of a coil cleaner with a pH in the range of 5 to 9. The coil must be rinsed thoroughly after cleaning.

In coastal areas, the coil should be cleaned with potable water several times per year to avoid corrosive buildup (salt).

Maintenance and service must be performed by a qualified installer or service agency. At the beginning of each cooling season, the system should be checked as follows:

Outdoor Unit

- 1 - Clean and inspect outdoor coil (may be flushed with a water hose). Ensure power is off before cleaning.
- 2 - Outdoor unit fan motor is pre-lubricated and sealed. No further lubrication is needed.
- 3 - Visually inspect all connecting lines, joints and coils for evidence of oil leaks.

- 4 - Check all wiring for loose connections.
- 5 - Check for correct voltage at unit (unit operating).
- 6 - Check amp draw on outdoor fan motor.

Motor Nameplate: _____ **Actual:** _____.

- 7 - Inspect drain holes in coil compartment base and clean if necessary.

NOTE – *If insufficient heating or cooling occurs, the unit should be gauged and refrigerant charge should be checked.*

Outdoor Coil

It may be necessary to flush the outdoor coil more frequently if it is exposed to substances which are corrosive or which block airflow across the coil (e.g., pet urine, cottonwood seeds, fertilizers, fluids that may contain high levels of corrosive chemicals such as salts)

- Outdoor Coil – The outdoor coil may be flushed with a water hose.
- Outdoor Coil (Sea Coast) – Moist air in ocean locations can carry salt, which is corrosive to most metal. Units that are located near the ocean require frequent inspections and maintenance. These inspections will determine the necessary need to wash the unit including the outdoor coil. Consult your installing contractor for proper intervals/procedures for your geographic area or service contract.

Indoor Unit

1. Clean or change filters.
2. Lennox blower motors are prelubricated and permanently sealed. No more lubrication is needed.
3. Adjust blower speed for cooling. Measure the pressure drop over the coil to determine the correct blower CFM. Refer to the unit information service manual for pressure drop tables and procedure.
4. Belt Drive Blowers - Check belt for wear and proper tension.
5. Check all wiring for loose connections.
6. Check for correct voltage at unit. (blower operating)
7. Check amp draw on blower motor.

Motor Nameplate: _____ **Actual:** _____.

Indoor Coil

- 1 - Clean coil if necessary.
- 2 - Check connecting lines, joints and coil for evidence of oil leaks.
- 3 - Check condensate line and clean if necessary.

HOMEOWNER

Cleaning of the outdoor unit's coil should be performed by a trained service technician. Contact your dealer and set up a schedule (preferably twice a year, but at least once a year) to inspect and service your outdoor unit. The following maintenance may be performed by the homeowner.

IMPORTANT

Sprinklers and soaker hoses should not be installed where they could cause prolonged exposure to the outdoor unit by treated water. Prolonged exposure of the unit to treated water (i.e., sprinkler systems, soakers, waste water, etc.) will corrode the surface of the steel and aluminum parts, diminish performance and affect longevity of the unit.

Outdoor Coil

The outdoor unit must be properly maintained to ensure its proper operation.

- Please contact your dealer to schedule proper inspection and maintenance for your equipment.
- Make sure no obstructions restrict airflow to the outdoor unit.
- Grass clippings, leaves, or shrubs crowding the unit can cause the unit to work harder and use more energy.
- Keep shrubbery trimmed away from the unit and periodically check for debris which collects around the unit.

Routine Maintenance

In order to ensure peak performance, your system must be properly maintained. Clogged filters and blocked airflow prevent your unit from operating at its most efficient level.

- 1 - **Air Filter** – Ask your Lennox dealer to show you where your indoor unit's filter is located. It will be either at the indoor unit (installed internal or external to the cabinet) or behind a return air grille in the wall or ceiling. Check the filter monthly and clean or replace it as needed.
- 2 - **Disposable Filter** – Disposable filters should be replaced with a filter of the same type and size.

NOTE – If you are unsure about the filter required for your system, call your Lennox dealer for assistance.

- 3 - **Reusable Filter** – Many indoor units are equipped with reusable foam filters. Clean foam filters with a mild soap and water solution; rinse thoroughly; allow filter to dry completely before returning it to the unit or grille.

NOTE – The filter and all access panels must be in place any time the unit is in operation.

- 4 - **Electronic Air Cleaner** – Some systems are equipped with an electronic air cleaner, designed to remove airborne particles from the air passing through the cleaner. If your system is so equipped, ask your dealer for maintenance instructions.
- 5 - **Indoor Unit** – The indoor unit's evaporator coil is equipped with a drain pan to collect condensate formed as your system removes humidity from the inside air. Have your dealer show you the location of the drain line and how to check for obstructions. (This would also apply to an auxiliary drain, if installed.)

Thermostat Operation

See the thermostat homeowner manual for instructions on how to operate the thermostat.

Heat Pump Operation

Your new Lennox heat pump has several characteristics that you should be aware of:

- Heat pumps satisfy heating demand by delivering large amounts of warm air into the living space. This is quite different from gas- or oil-fired furnaces or an electric furnace which deliver lower volumes of considerably hotter air to heat the space.
- Do not be alarmed if you notice frost on the outdoor coil in the winter months. Frost develops on the outdoor coil during the heating cycle when temperatures are below 45°F (7°C). An electronic control activates a defrost cycle lasting 5 to 15 minutes at preset intervals to clear the outdoor coil of the frost.
- During the defrost cycle, you may notice steam rising from the outdoor unit. This is a normal occurrence. The thermostat may engage auxiliary heat during the defrost cycle to satisfy a heating demand; however, the unit will return to normal operation at the conclusion of the defrost cycle.

Extended Power Outage

The heat pump is equipped with a compressor crankcase heater which protects the compressor from refrigerant slugging during cold weather operation.

If power to your unit has been interrupted for several hours or more, set the room thermostat selector to the EMERGENCY HEAT setting to obtain temporary heat without the risk of serious damage to the heat pump.

In EMERGENCY HEAT mode, all heating demand is satisfied by auxiliary heat; heat pump operation is locked out. After a six-hour compressor crankcase warm-up period, the thermostat can be switched to the HEAT setting and normal heat pump operation may resume.

Preservice Check

If your system fails to operate, check the following before calling for service:

- Verify room thermostat settings are correct.
- Verify that all electrical disconnect switches are ON.
- Check for any blown fuses or tripped circuit breakers.
- Verify unit access panels are in place.
- Verify air filter is clean.
- If service is needed, locate and write down the unit model number and have it handy before calling.

Accessories

For update-to-date information, see any of the following publications:

- Lennox EL15XP1 Product Specification bulletin
- Lennox Product Catalog
- Lennox Price Book

Wiring and Sequence of Operation

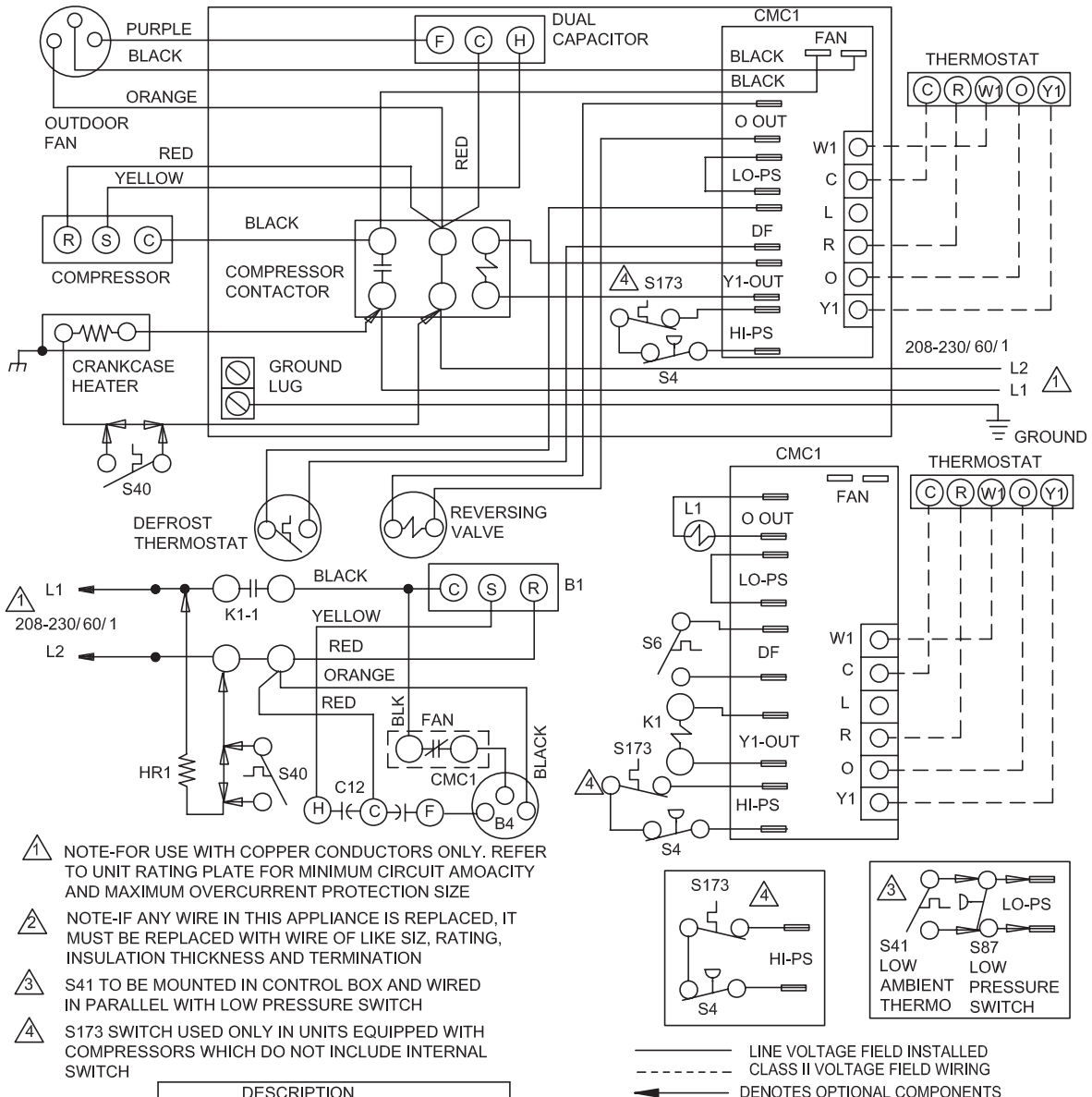

KEY	DESCRIPTION
B1	COMPRESSOR
B4	MOTOR-OUTDOOR FAN
C12	CAPACITOR-DUAL
CMC1	CONTROL-DEFROST
HR1	HEATER-COMPRESSOR
K1,-1	CONTACTOR-COMPRESSOR
L1	VALVE-REVERSING
S4	SWITCH-HIGH PRESSURE
S6	SWITCH-DEFROST
S40	TERMOSTAT-CRANKCASE
S41	TERMOSTAT-LOW AMBIENT
S87	SWITCH-LOW PRESS, COMP 1
S173	SWITCH-THERMAL PROTECTION

FIGURE 13. Typical Unit Wiring

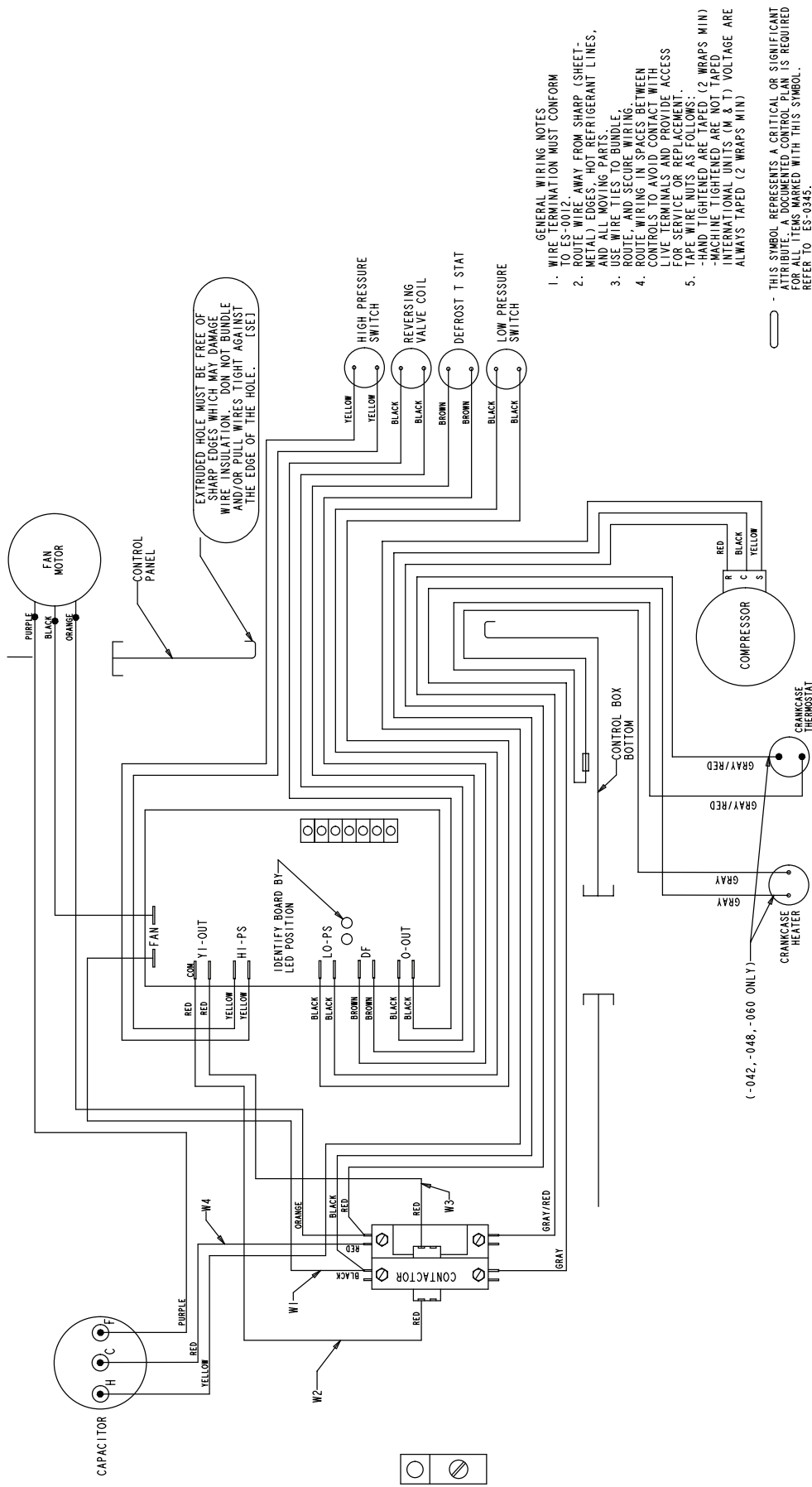

- GENERAL WIRING NOTES**
1. WIRE TERMINATION MUST CONFORM TO ES-0012.
 2. ROUTE WIRE AWAY FROM SHARP (SHEET-METAL) EDGES, HOT REFRIGERANT LINES, AND ALL MOVING PARTS.
 3. USE WIRE TIES TO BUNDLE, ROUTE, AND SECURE WIRING.
 4. ROUTE WIRING IN SPACES BETWEEN CONTROLS TO AVOID CONTACT WITH REFRIGERANT LINES. PROVIDE ACCESS FOR SERVICE AND REPAIR.
 5. TAP WIRE NUTS AS FOLLOWS:
 - HAND TIGHTENED ARE TAPED. (2 WRAPS MIN)
 - MACHINE TIGHTENED ARE NOT TAPED.
 - INTERNATIONAL UNITS (M & T) VOLTAGE ARE ALWAYS TAPED (2 WRAPS MIN)

THIS SYMBOL REPRESENTS A CRITICAL OR SIGNIFICANT COMPONENT. THE PART NUMBER IS REQUIRED FOR ALL ITEMS MARKED WITH THIS SYMBOL. REFER TO ES-0345.

FIGURE 14. Typical Factory Wiring

EL15XP1 OPERATING SEQUENCE

This is the sequence of operation for EL15XP1 series units. The sequence is outlined by numbered steps which correspond to circled numbers on the adjacent diagram. The steps are identical for both cooling and first stage heating demand with the exception reversing valve L1 is energized during cooling demand and de-energized during heating demand.

NOTE – Transformer in indoor unit supplies power (24 VAC) to the thermostat and outdoor unit controls.

COOLING:

Internal thermostat wiring energizes terminal O by cooling mode selection, energizing the reversing valve L1.

- 1 - Demand initiates at Y1 in the thermostat.
- 2 - 24VAC energizes compressor contactor K1.
- 3 - K1-1 N.O. closes, energizing compressor (B1) and outdoor fan motor (B4).

END OF COOLING DEMAND:

- 4 - Demand is satisfied. Terminal Y1 is de-energized.
- 5 - Compressor contactor K1 is de-energized.
- 6 - K1-1 opens and compressor (B1) and outdoor fan motor (B4) are de-energized and stop immediately.

FIRST STAGE HEAT:

Internal thermostat wiring de-energizes terminal O by heating mode selection, de-energizing the reversing valve L1.

See steps 1, 2 and 3.

End of FIRST STAGE HEAT:

See steps 4, 5 and 6.

DEFROST MODE:

When a defrost cycle is initiated, the control energizes the reversing valve solenoid and turns off the condenser fan. The control will also put 24VAC on the "W1" (auxiliary heat) line. The unit will stay in this mode until either the coil sensor temperature is above the selected termination temperature, the defrost time of 14 minutes has been completed, or the room thermostat demand cycle has been satisfied. (If the temperature select shunt is not installed, the default termination temperature will be 90°F.) If the room thermostat demand cycle terminates the cycle, the defrost cycle will be held until the next room thermostat demand cycle. If the coil sensor temperature is still below the selected termination temperature, the control will continue the defrost cycle until the cycle is terminated in one of the methods mentioned above. If a defrost is terminated by time and the coil temperature did not remain above 35°F (2°C) for 4 minutes the control will go to the 30-minute Time/Temperature mode.

Servicing Units Void of Charge

If the outdoor unit is void of refrigerant, clean the system using the procedure described below.

- 1 - Leak check system using procedure outlined on page 16.
- 2 - Evacuate the system using procedure outlined on page 17.
- 3 - Use nitrogen to break the vacuum and install a new filter drier in the system.
- 4 - Evacuate the system again using procedure outlined on page 17.
- 5 - Weigh in refrigerant.

Start-Up

IMPORTANT

If unit is equipped with a crankcase heater, it should be energized 24 hours before unit start-up to prevent compressor damage as a result of slugging.

- 1 - Rotate fan to check for binding.
- 2 - Inspect all factory and field-installed wiring for loose connections.
- 3 - After evacuation is complete, open the liquid line and suction line service valves to release the refrigerant charge (contained in outdoor unit) into the system.
- 4 - Replace the stem caps and tighten as specified in Operating Service Valves on page 7.
- 5 - Check voltage supply at the disconnect switch. The voltage must be within the range listed on the unit's nameplate. If not, do not start the equipment until you have consulted with the power company and the voltage condition has been corrected.
- 6 - Set the thermostat for a cooling demand. Turn on power to the indoor indoor unit and close the outdoor unit disconnect switch to start the unit.
- 7 - Recheck voltage while the unit is running. Power must be within range shown on the nameplate.
- 8 - Check system for sufficient refrigerant by using the procedures listed under Start-Up and Charging Procedures.
- 9 - Recheck voltage while the unit is running. Power must be within range shown on the nameplate.

Start-Up and Performance Checklist

Job Name _____ Job no. _____ Date _____

Job Location _____ City _____ State _____

Installer _____ City _____ State _____

Unit Model No. _____ Serial No. _____ Service Technician _____

Nameplate Voltage _____

Rated Load Ampacity _____ Compressor _____ Outdoor Fan _____

Maximum Fuse or Circuit Breaker _____

Electrical Connections Tight? Indoor Filter clean? Supply Voltage (Unit Off) _____

Indoor Blower RPM _____ S.P. Drop Over Indoor (Dry) _____ Outdoor Coil Entering Air Temp. _____

Discharge Pressure _____ Vapor Pressure _____ Refrigerant Charge Checked?

Refrigerant Lines: - Leak Checked? <input type="checkbox"/> Properly Insulated? <input type="checkbox"/>	Outdoor Fan Checked? <input type="checkbox"/>
---	---

Service Valves: --- Fully Opened? <input type="checkbox"/> Caps Tight? <input type="checkbox"/>	Thermostat
--	-------------------

Voltage With Compressor Operating _____	Calibrated? <input type="checkbox"/> Properly Set? <input type="checkbox"/> Level? <input type="checkbox"/>
---	---